

# INSTALLATION INSTRUCTIONS & PARTS DIAGRAMS

## Traffic Doors



**JAMBS MUST BE SQUARE AND PLUMB; MINIMUM OF 3-1/2 INCH WIDE JAMBS REQUIRED TO MOUNT HARDWARE**

1: Measure width and height of framed opening and verify dimensions given at time of ordering. *If incorrect, contact Customer Service Representative. MODIFICATION OF PANEL WILL VOID WARRANTY.*

2: Place the top hardware against the jamb edge and top header of the door frame, making sure that it is centered in the jamb. Mark the hole locations and drill pilot holes. (If frame is wood: use 1/8" drill bit. If frame is metal: use 7/32" drill bit.)

3: Secure the top hardware using the correct fasteners provided (If frame is wood/sheet metal: use #14 x 1" flat head screws. If frame is metal: use 1/4-20 x 1" flat head thread cutting screws).

4: Place the bottom pin assembly or jamb guard assembly against the jamb edge and floor, making sure that it is aligned and plumb with the top hardware. Mark and drill locations in the jamb and floor using the appropriate bits (If material is wood/sheet metal: use 1/8" bit. If material is metal, use 7/32" bit. If material is concrete: use 3/8" masonry bit).

5: Secure the bottom hardware using the proper fasteners provided (If material is wood/sheet metal: use #14 x 1" flat head screws. If material is metal, use thread cutting screws. If material is concrete: use 3/8" x 3" concrete anchors).

*NOTE: If bottom hardware is used with lightweight door, ensure supplied nylon bushing is over pin before installing the panel.*

6: Verify that the bottom pin hole and the rollers in the top hardware are greased. Proper greasing locations shown with \* .

7: Slip door over bottom pin.

8: Lift slightly and slide top pod over bearing plate as shown in Figure 1. The panel should hang without fasteners at this time. Line up holes and insert bolts supplied.

9: Hand tighten two nylon lock nuts onto the 5/16" x 3/4" bolts.

10: Assure that the door is plumb and square to the opening, as shown in Figure 2. Assure that the door comes to rest plumb and in the midline of the frame when it is closed.

11: Finish tightening the lock nuts onto the bolts, securing the panel in place.

12: Install the cover plates in the correct orientation on one or both sides of the door using the provided hardware.

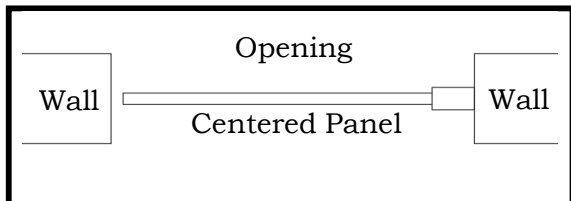

**Figure 2**

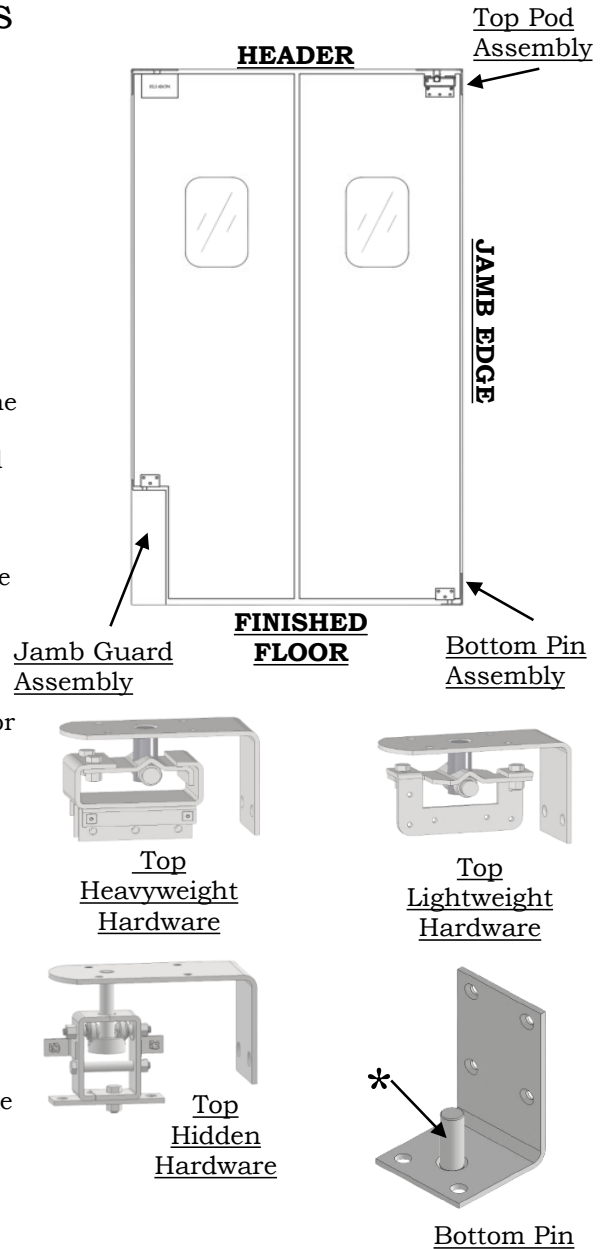

**Figure 1**

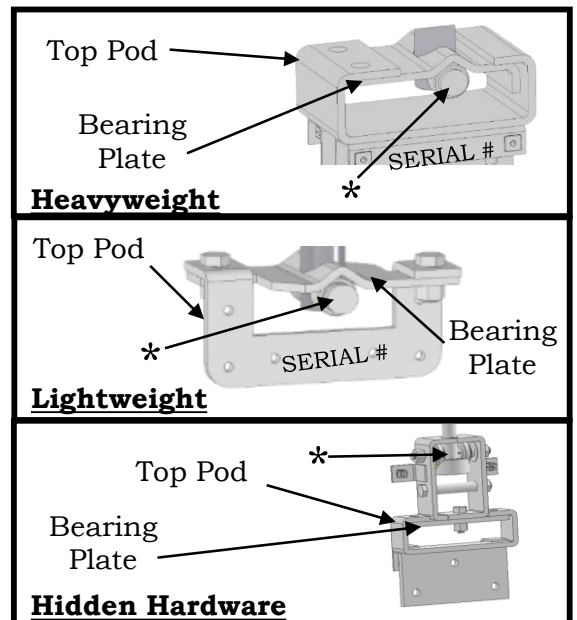

# **TROUBLESHOOTING CHECKLIST**

**PROBLEM:** Door(s) will not return to closed or centered position.

- 1) Is finished door(s) opening size correct? Is the opening square and plumb?
  - If opening size is wrong, consult customer service representative
  - If opening is not square or plumb, try to align by shimming behind either top or bottom hardware - or both.
- 2) Is there a significant difference in air pressure on one side of the door?
  - If yes, contact customer service representative for suggestions.
- 3) Make sure rollers in top hardware assembly are lubricated and turn freely.
  - See Maintenance Guide below.
- 4) Confirm the top hardware bearing plate is correctly located in the door pod.
  - Contact customer service representative for suggestions.
- 5) If applicable, check edge gaskets for excessive contact with the jamb.
  - Bottom gasket on certain door models is adjustable.

**PROBLEM:** Door(s) comes off bottom pin when fully opened.

- 1) Check for correct finished opening height. Verify that the door matches the tag on the shipping carton.

**PROBLEM:** Excessive gap between doors.

- 1) If excessive, check finished opening width and compare it to opening size on order.
- 2) Consult customer service representative.

**PROBLEM:** Opening too small.

- 1) The opening must be adjusted.
- 2) Verify that the door matches the tag on the shipping carton.
- 3) Consult customer service representative.

**PROBLEM:** Door(s) unit makes noise during operation.

- 1) Make sure top hardware rollers and bearing plate are lubricated. See Maintenance Guide below.  
*Note:* There is a design clearance incorporated in the bottom hardware assembly. (Bottom pin and door bottom leaf), and therefore some movement is normal.

*Note:* Fasteners can be purchased from local lumber or hardware stores. Reference install instructions for specifics.

## **MAINTENANCE GUIDE**

**LUBRICATION:** Use only suitable grease (such as Lubriplate or White Lithium Grease) to lubricate top rollers, bearing plate, and bottom pin. **DO NOT USE OIL OR GRAPHITE BASED PRODUCTS.** *Check for lubrication at least every 2 months.* Lubricate as needed.

**CLEANING THE DOOR SURFACE:** Clean plastic, laminate, aluminum, and stainless steel surfaces with non-corrosive and non-abrasive products. Cleaning products intended for appliances work well. **DO NOT USE ACETONE.**

CURTRON PRODUCTS  
www.curtronproducts.com  
Telephone: 800.833.5005  
email: [customercare@senneca.com](mailto:customercare@senneca.com)



Curtron Products  
Webpage