

# FOUR-FOLD



ELECTRICAL

## INSTALLATION INSTRUCTIONS



DoorEngineering.com  
800.959.1352



# Table of Contents



<u>Important Notice</u>	<u>3</u>
<u>Before Door Installation:</u>	<u>3</u>
<u>Before Operator Installation:</u>	<u>3</u>
<u>Operator Install:</u>	<u>3</u>
<u>Safety Practices:</u>	<u>3</u>
<u>Installation Instructions</u>	<u>3</u>
<u>CEDES Grid Scan/Pro 10-20-102</u>	<u>3</u>
<u>Miller Edge RLC-K72 10-20-106</u>	<u>9</u>
<u>BEA IS40P 10-00-273</u>	<u>11</u>
<u>BEA LZR Widescan 10-00-734</u>	<u>15</u>
<u>Red and Green LED Light Strips</u>	<u>18</u>
<u>Troubleshooting</u>	<u>20</u>
<u>WARNING</u>	<u>29</u>
<u>Notes</u>	<u>32</u>

## **WARNING**

### Before Door Installation:

- **READ AND FOLLOW ALL INSTALLATION INSTRUCTIONS.** Review with installation team.
- Verify required documents are correct (E1, Operator Layout, etc.)
- Verify that installation equipment (Telehandler, Forklift, Crane, etc.) is rated to handle the weight of the door.
- Verify that the door is the correct size for the opening. Measure and inspect the openings width and dimensions (reference included as-built drawings).
- Ensure that work area is clear of dirt and debris.

### Before Operator Installation:

- **ALL ELECTRICAL WIRING MUST BE DONE BY A CERTIFIED ELECTRICIAN.**
- Read the *CW Automation Door Controller Setup Manual* provided with the control panel.
- Refer to all applicable local electrical codes.
- Always refer to National Electric Code.
- Always disconnect Main Power before doing any electrical work.
- Verify that proper Over-Current and Short-Circuit prevention will be used.
- CW Automation Contact: (507)-665-4186

### Operator Install:

- A door that is operating improperly could cause severe injury. Have qualified service personnel make repairs or adjustments to panels and other hardware before installing the Operator.
- Place and constrain door panels in the closed position **before** connecting Operator.
- Installation of door Operator must be done by a qualified installer.
- Install Door Operator at least 8 feet or more above the floor.
- Do not connect the Door Operator to the source of power until indicated in the instructions.
- Locate the Control Panel:
  - Insight of door system
  - At a minimum height of 5 feet from finished floor to bottom of Control Panel
  - Away from all moving parts of door system

### Safety Practices:

- All labels are provided in the “Safety Label Kit”.
- Install the “Entrapment Warning” label next to the Control Station in a prominent location.
- Before operating, always check clearance around the door for any person or object that may be in the door(s)’s path. Never store items in or near the area of door travel.
- If you have any questions about the safety of the door operating system. Contact Door Engineering & Manufacturing at **1-800-959-1352**.

# CEDES GridScan/Pro

## DE# 10-20-102

The emitter and receiver edges create a grid of infrared beams offering up to (8.2 ft) in protection height. When the infrared beams are interrupted, the output sends a signal to the connected door control unit. As soon as the detection area is clear again, the output switches to indicate that the area is "clear".

### 1.1 Package Contents

- 1 × GridScan/Pro emitter edge (Tx)
- 1 × GridScan/Pro receiver edge (Rx)
- 1 × Synchronization cable 10 m (33 ft)
- 1 × Connection cable 5 m (16.5 ft)
- 1 × Installation guide
- 1 × Hardware kit #10-05-019
- 1 × Extra Sync Extension #10-20-103 (For doors 14x14 or larger).



### 1.2 General Instructions and Precautions

- Never scratch or paint the optical lenses because they form the light path! Do not drill additional holes into the profile. Unpack the profiles just before installation in order to avoid damage.
- Do not bend or twist the edges!
- Oil can damage the cables. Contamination must be avoided at all times!
- Chemicals can damage the profile and optical characteristics. Contact must be avoided at all times!
- Although the GridScan/Pro is insensitive to direct sunlight, avoid all unnecessary exposure if possible, most especially to the receiver.
- Avoid interference from blinking lights or infrared light sources such as photo cells or other light curtains.
- Do not install the GridScan/Pro in places where the emitter and receiver edges are directly exposed to light sources such as FL tubes or energy saving lamps.
- Make sure to place the connection plugs for both the emitter and receiver at the same end.

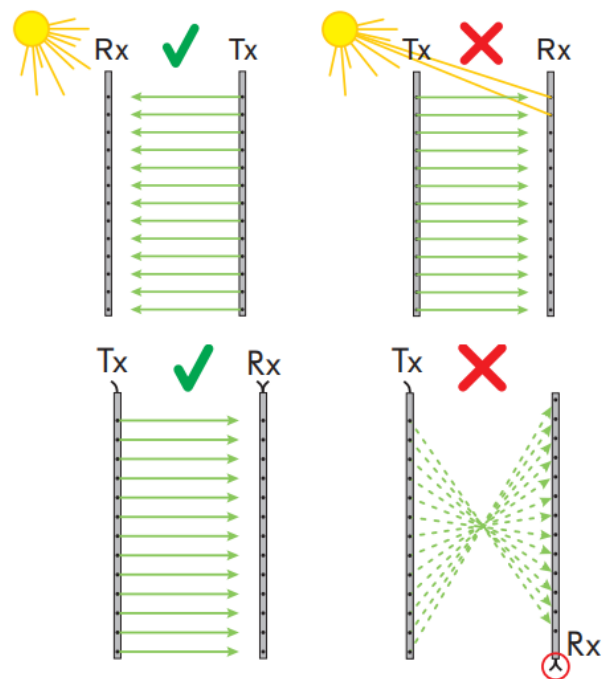

## 1.3 Installation/Alignment

- The optical axis of the emitter (Tx) and the receiver edge (Rx) need to be aligned towards each other to ensure the light curtain functions reliably.
- A self-calibration on each optical beam is implemented. At the power-up the ideal emitting strength will be detected and used. To reduce interruption caused by dust the system checks the emitting power and adapts a new higher or lower strength if necessary.



### WARNING

#### Electrical and mechanical hazards

Electrical shock and unexpected door movement can cause serious injury or death.

- ▶ Follow all applicable safety measures.
- ▶ Use only specific and approved tools.
- ▶ If the GridScan/Pro has to be adjusted, the main power supply must be switched off and marked as out of service.

### NOTICE

#### Mechanical damage to the GridScan/Pro

- ▶ Do not drill additional holes into the light curtain.
- ▶ Do not overtighten the mounting screws.
- ▶ Mount the edges on a flat surface.

1. Receiver and emitter must be mounted at the same height
2. CEDES Grid/Scan/Pro must be mounted a minimum of 3 inches away from the door face, or positioned far enough so that the fold hinges or any object protruding from the door surface are not detected.
3. Check alignment of the edges. The receiver must be mounted 180 degrees opposite to the emitter.
4. Drill holes for the mounting brackets (Part# 10-05-019)
5. Attach mounting clips to surface you will be mounting the GridScan/Pro to
6. Clip in light curtains to the brackets.
7. Connect the synchronization cable (black plug) to the receiver edge and run the cable up and over the header or in pre-installed conduit to the emitter side. Connect the synchronization cable (black plug) to the emitter edge.
8. Connect the connection cable (blue plug) to the receiver edge and guide the cable to the CW Control Panel.

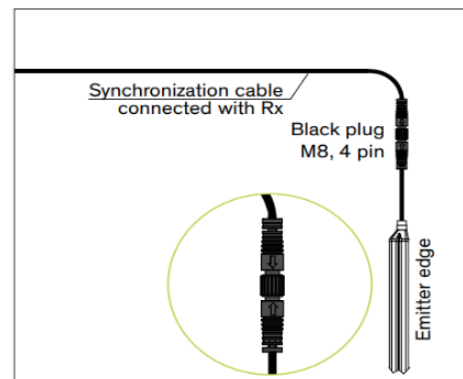
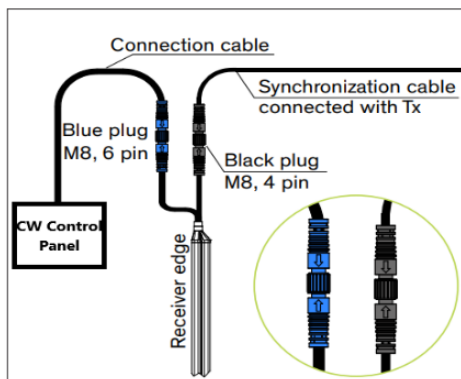

# CEDES GridScan/Pro

DE# 10-20-102

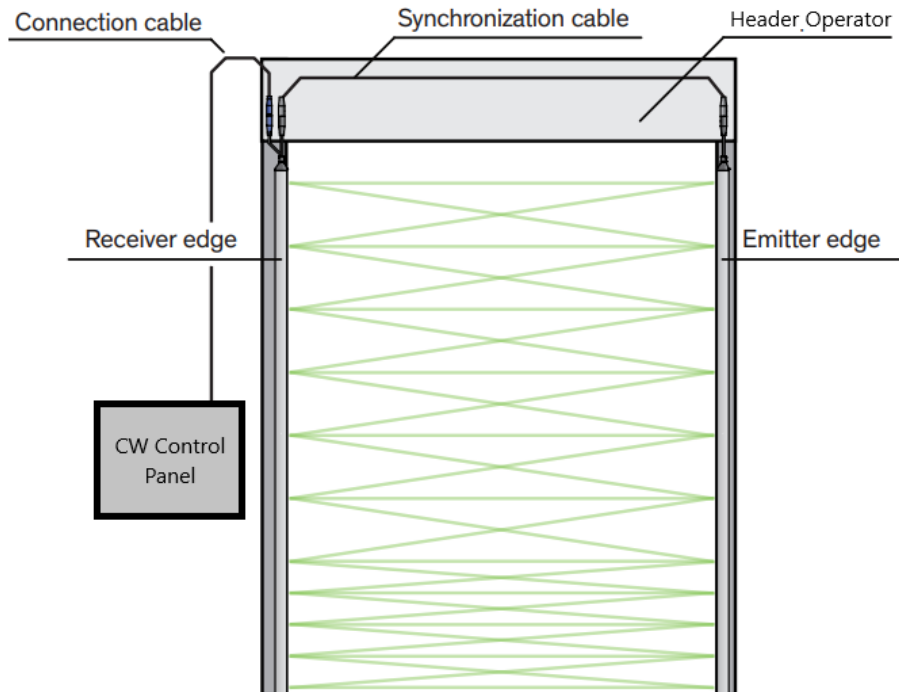

## 1.4 Electrical Connection:

- White and **Brown**: 24H
- Grey and **Blue**: 24N
- Black: Signal Input 280 on Panel
- **Green**: Not used

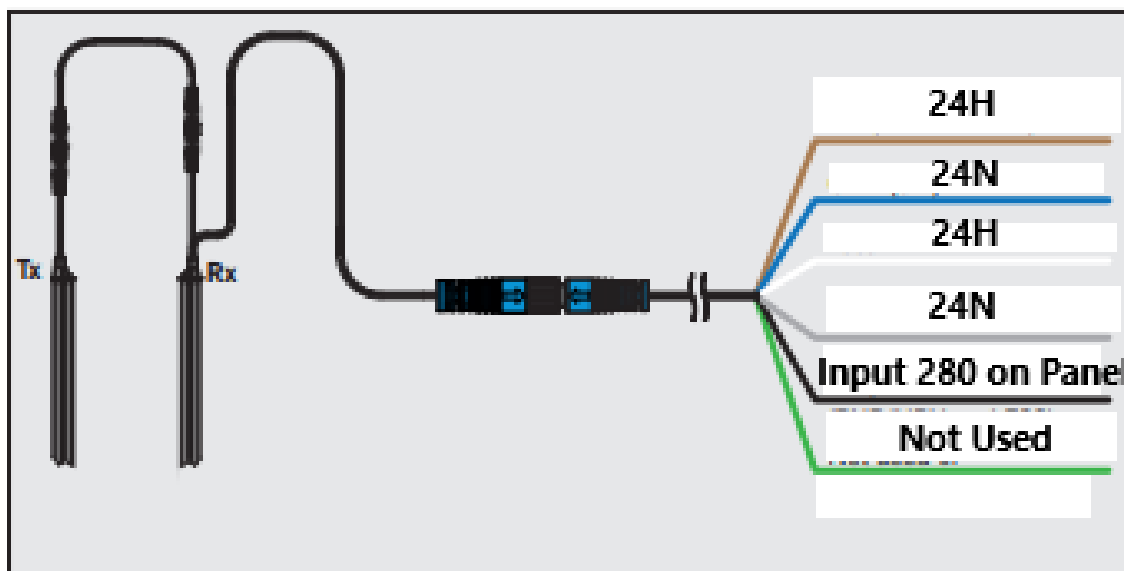

# CEDES GridScan/Pro

DE# 10-20-102

## 1.5 Start-UP

- Switch on main disconnect located on the front cabinet of the control panel and allow to start up. The LED on the receiver edge blinks during the start-up phase.
- Check the LED on both edges (power, status).
- Check the top corner of the display on the PLC to ensure no errors are displayed. (If light curtains are wired improperly, you will get safety eye error).
- Test if the system is working correctly.
- Interrupt the light curtain and check if the LED status on receiver edge changes.
- Start a door closing cycle and interrupt the light curtain again. The door must stop closing and open again (depending on the controller setting).
- Start a complete door closing cycle and check that the door closes completely without problems.

## 1.6 LED Status Description

### Receiver edge (Rx)

Green LED	Red LED	Sensor status
●	○	Light curtain free
○	●	Safeguarded area interrupted or door closed
○	⦿	Start-up (slow blinking)
○	⦿	Internal malfunction (fast blinking)
○	○	No power or edge is defective (see Chapter 13)
⦿	○	Static mode configured (blinking with 1 Hz / $\leq 2$ min)

### Emitter edge (Tx)

Green LED	Sensor status
●	Power OK
○	No power or edge is defective (see Chapter 13)

**Table 5:** LED status description emitter edge

● = LED on    ○ = LED off    ⦿ = LED blinking

# CEDES GridScan/Pro

## DE# 10-20-102

### 1.7 Troubleshooting

Tx LED Green	Rx LED Green	Rx LED Red	Action
LED off	LED off	LED off	<ul style="list-style-type: none"> <li>▶ Check electrical connections.</li> <li>▶ Check supply voltage of the door controller.</li> </ul>
LED off	LED off	LED red	<ul style="list-style-type: none"> <li>▶ Check the connection of the synchronization cable.</li> </ul>
LED green	LED green	LED off	<ul style="list-style-type: none"> <li>▶ Make sure the sensor edges are not mounted close to any shiny or reflective surface.</li> <li>▶ Restart the system.</li> </ul>
LED off/on (flickering green)	LED off	LED off/on (flickering red)	<ul style="list-style-type: none"> <li>▶ Check power supply.</li> <li>▶ Check connections.</li> </ul>
LED green	LED off	LED off/on (slow blinking red)	<ul style="list-style-type: none"> <li>▶ Make sure the safeguarded area is clear of interruption.</li> <li>▶ Check the alignment of the light curtain.</li> <li>▶ Clean elements.</li> </ul>
LED green	LED on/off (flickering green)	LED off/on (flickering red)	<ul style="list-style-type: none"> <li>▶ Make sure the safeguarded area is clear of interruption.</li> <li>▶ Clean the elements.</li> <li>▶ Make sure that the cables and edges are located away from sources of electromagnetic interference.</li> <li>▶ Ensure that the emitter and receiver are correctly aligned and remain so during door closure (e.g. that vibrations do not cause edges to become misaligned).</li> <li>▶ Restart the system.</li> </ul>
LED green	LED off	LED red	<ul style="list-style-type: none"> <li>▶ Make sure the safeguarded area is clear of interruption.</li> <li>▶ Reopen door completely.</li> <li>▶ Clean the elements.</li> <li>▶ Check the alignment of the light curtain.</li> <li>▶ Check that the test input is connected to the test output signal of the door control unit and that the signal level and logic (HIGH/LOW) are correct. If the test input is not used, connect it permanently to USP.</li> <li>▶ Measure the USP voltage.</li> <li>▶ Restart the system.</li> </ul>
LED off	LED off	LED off/on (slow blinking red)	<ul style="list-style-type: none"> <li>▶ Check the connection of the synchronization cable.</li> </ul>
LED green	LED off	LED off/on (red, fast blinking, 5 Hz)	<p><b>Internal error occurred</b></p> <ul style="list-style-type: none"> <li>▶ Restart the system.</li> <li>▶ Replace Rx edge.</li> </ul>
LED green	LED blinking	LED off	<ul style="list-style-type: none"> <li>▶ Check if the selected configuration is correct (static mode selected)</li> </ul>

# Miller Edge RLC-K72/36

DE# 10-20-16



The Relay Light Curtain (RLC-K36, RLC-K72) is a non-monitored, fail-safe photo optic solution that has a normally open and a normally closed dry contact output.

## Package Contents

- **RLC-K36:** 3 ft., 8 elements
  - (1) Emitter
  - (1) Receiver
  - (4) Universal mounting brackets
  - (8) #4 ½ inch zinc plated oval head self-tapping screws
  - Rubber Caps
- **RLC-K72:** 6 ft., 16 elements
  - (1) Emitter
  - (1) Receiver
  - (6) Universal mounting brackets
  - (12) #4 ½ inch zinc plated oval head self-tapping screws
  - Rubber Caps

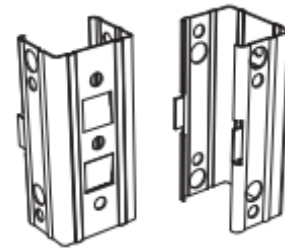
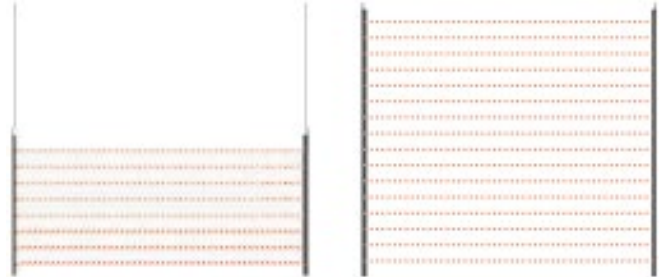

IMAGE 2:  
UNIVERSAL MOUNTING BRACKETS

## Installation/ Alignment

- Identify the emitter (2 wires) and the receiver (5 wires).
- Identify the locations you will install the Light Curtains, usually close to the door tracks on the inside of the door opening. Be certain no part of the moving door will obstruct the infrared beams.
- Install the universal mounting brackets onto the mounting points, using the hardware. The brackets should be installed approximately 6 inches from the top and bottom ends of the emitter and receiver. For RLC-K72, a third bracket should be installed centered between the top and bottom brackets. Make sure the brackets are all in-line.
- Install the emitter and receiver by clipping them into the mounting brackets. The flat surfaces of the emitter and receiver, where the optics are located, should point at each other, across the door opening.
- Install one rubber cap per light curtain, covering the wire outlet. With the Wire exiting the top of the light curtain, fold the wire at the strain relief and slid the cap over the top.





# BEA IS40P Presence Sensor

DE# 10-00-273



When the infrared beams are interrupted, the output sends a signal to the connected door control unit. As soon as the detection area is clear again, the output switches to indicate that the area is "clear".

## Installation/ Alignment

- Unit should be mounted below the operator to the center track bracket utilizing the IS40P mounting bracket.
- Typical units should be installed at a 30-degree angle from the metal sensor bracket.
- Always check placement of all wiring before powering up to ensure that moving door parts will not catch any wires and cause damage to the equipment.

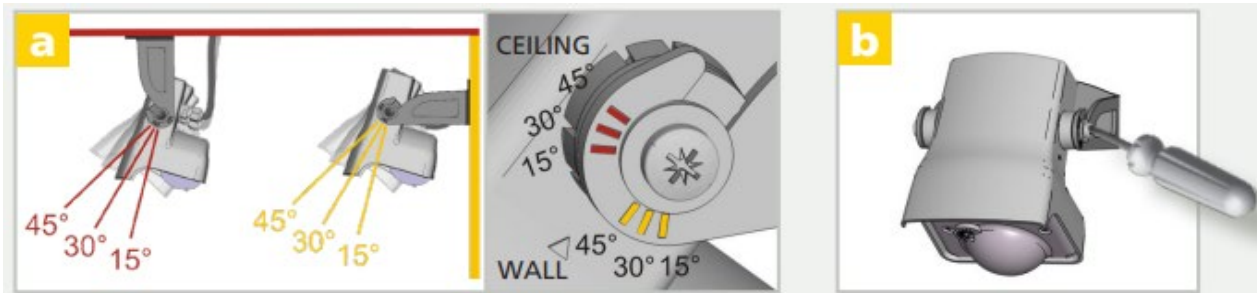
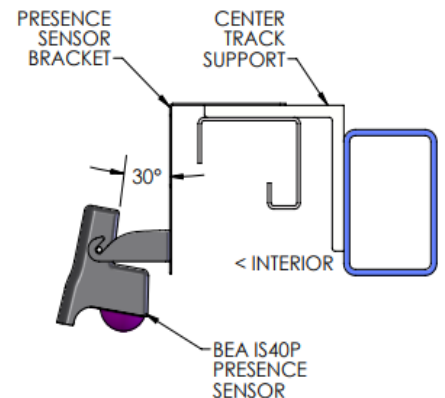

## Electrical Connection

**RED** 24H  
**BLACK** 24N

**POWER SUPPLY**

**WHITE/BLACK** 280  
**GREEN/BLACK** Not Used  
**YELLOW/BLACK** 281

**AIR OUTPUT 2**  
 Presence signal

**RELAY CONFIGURATION**

*see Appendix for How To Use the Remote Control*

	Motion Relay	Presence Relay
1	active	passive
2	passive	active
3	passive	passive
4	active	active

# BEA IS40P Presence Sensor

DE# 10-00-273



## Programming the IS40P

Listed below the recommended factory settings for the IS40P units are noted below:

- **Immunity Settings:**
  - Should be set to #3 (Snow)
- **Automatic Learn Time:**
  - Setting to be set at No Learn #9
- **IR Air Detection Field:**
  - Typical setting would be #3, alternate option would be #8
- **IR Target Size:**
  - Typical setting would be #1, alternate option would be #2 or #5

The sensitivity of the system will diminish the larger the chosen target size so verify what size vehicle is using the door system to ensure the IS40P senses it.

		0	1	2	3	4	5	6	7	8	9	0	0
OUTPUT REDIRECTION	R1	presence	air entry pulse	air exit pulse	first or last line air entry pulse	first or last line air exit pulse	presence	presence					
	F1												
	R2	presence	presence	presence	presence	presence	presence	presence					
FREQUENCY	DE		A	B									
MAX. PRES. DETECTION TIME		30 s	1 min	2 min	5 min	10 min	20 min	1 h	1 h 30	2 h	no learn*		
IR CURTAIN IMMUNITY			low	normal	high								
TARGET SIZE**	F2												
AIR DETECTION FIELD	BE												

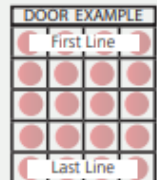

Once settings have been adjusted Launch a setup to take a reference picture to complete the programming process.

**Step out of the detection field and do not leave any tools inside the detection field.**

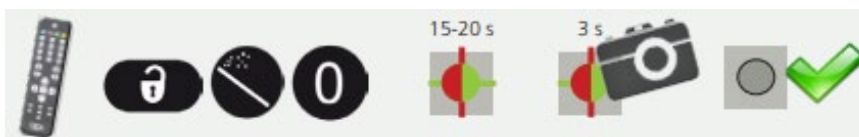

# BEA IS40P Presence Sensor

DE# 10-00-273

## Troubleshooting

	The door never closes and the LED is ON.	Object in the AIR detection area.	Move objects or reduce automatic learn time. Wait for learn time to expire and/or Launch a setup or cycle power.
	The door remains closed and the LED is OFF.	The sensor power is off.	Check the wiring and the power supply.
	The infrared sensor does not react.	The infrared power emission is too low according to the mounting height.	Launch a new setup. Step out of the detection field!
		Improper Target Size.	Ensure the target size is not too large or larger than the pattern size.
	The door opens and closes constantly.	The sensor is disturbed by the door motion or vibrations caused by the door motion.	Make sure the sensor is anchored properly.
			Increase the sensor angle.
			Reduce the AIR detection zone.
	Sporadic presence detections for no reason.	The presence detection is disturbed by rain or lamps.	Set the AIR-curtain immunity to value 3.
		The sensor is not installed properly.	Fasten the sensor firmly.
	The red LED is permanently ON after a setup.	The sensor has failed the AIR-setup.	Launch a new setup and step out of the detection field.
	The setup lasts more than 30 seconds.	The setup is disturbed.	Make sure the detection field is clear and launch a new setup.
		Another sensor causes interference.	Select a different frequency for each sensor.

# BEA IS40P Presence Sensor

DE# 10-00-273

## Troubleshooting

 The sensor does not unlock and the red LED flashes quickly.	The sensor needs an access code to unlock.	Enter the right access code.  If you do not know the access code, delete an unknown code (see page 7).
	The sensor does not respond to the remote control.	The remote control batteries are weak or improperly installed.
The remote control is poorly aimed.		Point the remote control towards the sensor.
The sensor is not powered.		Check the power supply of the sensor.



Only trained and qualified personnel are recommended to install and set up the sensor.

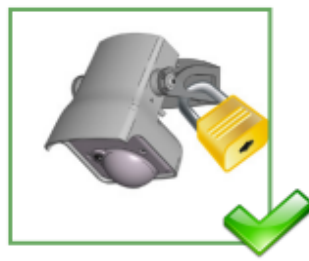

After installation, save an access code to lock the sensor.



Always test the proper operation of the installation before leaving the premises.

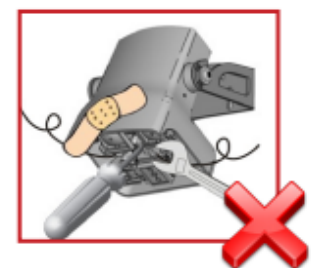

The warranty is invalid if unauthorized repairs are made or attempted by unauthorized personnel.

# BEA LZR Widescan

DE# 10-00-732

BEA's LZR-WIDESCAN is a LASER-based, Time-of-Flight sensor used for motion, safety and presence detection.

## Mounting the BEA LZR Widescan

- Mount the BEA LZR Widescan to the IS40P mounting bracket located in the center of the doors and under the operator.
- The BEA LZR Widescan should be mounted low enough to ensure the drive arm will not come in contact with the sensor.

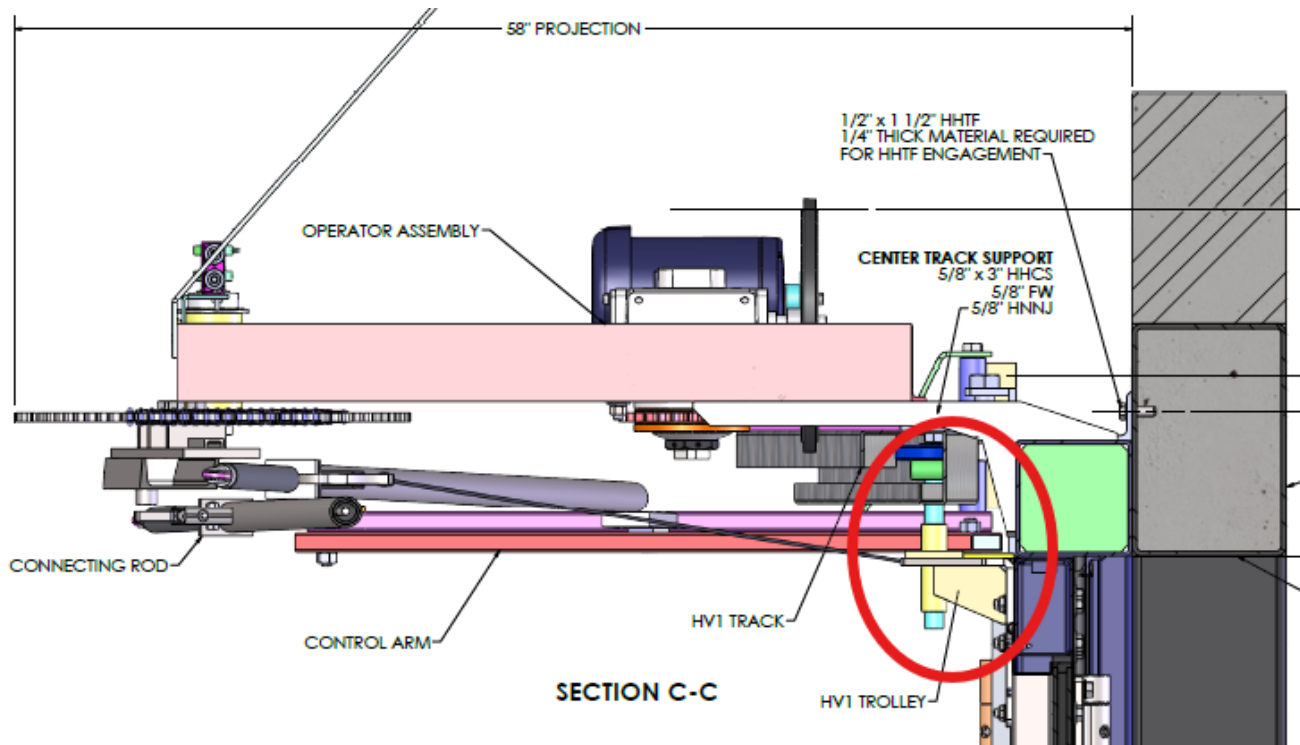

## Electrical Connection

24N	black	Power supply
24H	red	Power supply
281	pink	Output 2
282	pink	Output 2

# BEA LZR Widescan

DE# 10-00-732



BEA's LZR-WIDESCAN is a LASER-based, Time-of-Flight sensor used for motion, safety and presence detection.

## Positioning the Detection Field

- Activate the 2 visible laser spots by pressing “OK” twice on the LCD or pressing “UNLOCK, WAND, WAND” on the remote control.
- Make sure the curtain is parallel to the door by adjusting one or both screws on the side of the sensor.
- Position the curtain closer to or farther away from the door by turning the screw at the top.
- When the safety function is required, the red spots should be as close to the door as possible.
- Launch the “**POSITION WIZARD**” to position the detection field correctly in front of the door.
- Push and hold “OK” on the LCD to launch the “**POSITION WIZARD**”.
- Rotate the sensor to align the center of the red spots with the center of the door. Push “OK” on the LCD.
- Rotate the sensor until the LCD screen validates the position. Push “OK” to exit.



## Programming

- Make sure the blue protection film and cover are removed from the sensor.
- The teach-in zone (the square in front of the 2 visible spots) must be completely clear.
- **A teach-in must be launched each time a sensor angle has been changed.**
- Use the VIEWER feature on the mobile app to verify the field size each time a field is changed.
- Check your profile settings on the mobile app before beginning installation. The "First Installation" profile has a simplified list of settings. The "Fine tuning" profile has the full list of settings. This should be used for installations requiring more customization.

# BEA LZR Widescan

DE# 10-00-732

## Teach-In: Install

### MOBILE APP

- Verify settings from the physical installation and then follow the prompt for the teach-in process to begin.
- Clear the area and press "Start teach-in process" at the bottom of the screen.
- The app will notify when the Teach-In is complete. Press "OK" to move forward to Outputs.

### REMOTE CONTROL

- Launch a teach-in by remote control. The Teach-In process will start after 5 seconds.
- Wait while the position, angle, and height are learned and the background is analyzed.
- The Teach-In will end automatically.

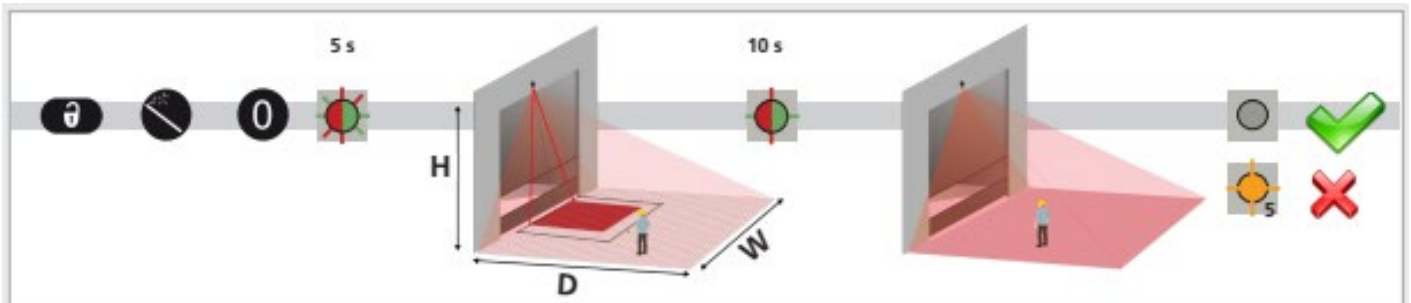

## LZR Settings

- Out1 Funct. → set to "Safety"
- Out2 Funct. → set to "Presence"
- Relay Funct. → set to "Motion"
- More → OKi.
- **Out 2 Logic** → "NC"

**Motion** (for 14'-0" x 14'-0" doors) - THIS WILL DISABLE THE MOTION FIELD, WHICH IS NOT BEING USED

Width → **0"** b. Depth/"Field Stop" → **0"**

**Presence** (for 14'-0" x 14'-0" doors) - ONLY THE PRESENCE FIELD IS BEING USED

Width → **96"** b. Depth/"Field Stop" → **84"**

Field Start (Door Zone Off) → **48"**

**Safety** (for 14'-0" x 14'-0" doors) - THIS WILL DISABLE THE MOTION FIELD, WHICH IS NOT BEING USED

Width → **0"** b. Depth/"Field Stop" → **0"**

- Launch a **Teach In** using the remote control or Mobile app to save all settings.
- Test Field Size a solid red light should appear when objects are in the field.

**NOTE: THE ABOVE SETTINGS ARE approximations for 14'x14' doors. Field Adjustment is required to optimize to field conditions.**

# BEA LZR Widescan

DE# 10-00-732



## Remote Control Sequences



After unlocking, the red LED flashes and the sensor can be adjusted by remote control.



If the red LED flashes quickly after unlocking, enter an access code from 1 to 4 digits. If you do not know the access code, **cycle power**.



To end an adjustment session, always lock the sensor.

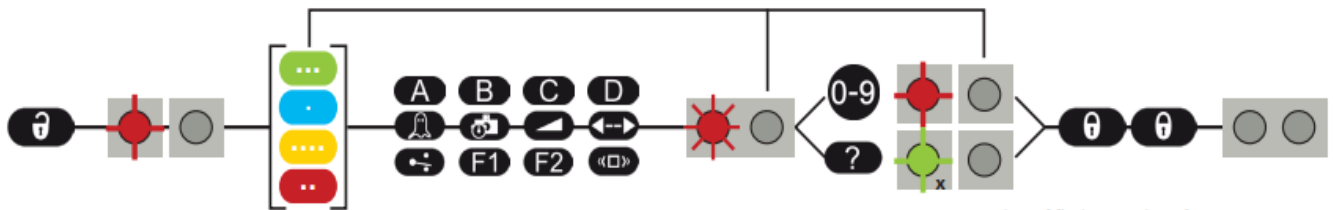

If necessary, select the corresponding detection field before selecting the parameter and changing the value. The second LED indicates the detection field.

x = number of flashes = value of parameter













## Troubleshooting

	N	EEPROM / Watchdog test	Cycle power. If error returns, replace sensor.
E1	E1: CPU-XXX	The sensor encounters an internal problem	Cycle power. If error returns, replace sensor.
E2	E2: XXX PWR	The ADP supply is faulty	Cycle power. If error returns, replace sensor.
		The LZR supply is faulty	1. Check power supply (Diagnostics menu in LCD) to ensure it is within specified range. 2. Cycle power. If error returns, replace sensor.
	E2: IN SUPPLY	The 5V supply is faulty	1. Check power supply (Diagnostics menu in LCD) to ensure it is within specified range. 2. Cycle power. If error returns, replace sensor.
	E2: IN SUPPLY	The power supply is too low or too high	1. Check power supply (Diagnostics menu in LCD) to ensure it is within specified range. 2. Cycle power. If error returns, replace sensor.
	E2: TEMP	The internal temperature is too low or too high	Check the sensor temperature (Diagnostics menu in LCD) to ensure it is within specified range. 1. Check power supply (Diagnostics menu in LCD) to ensure it is within specified range. 2. Cycle power. If error returns, replace sensor.
	E3: RXTX PWM	DCA Communication error	Set Heating mode to "auto." Protect the sensor from direct exposure to heat or cold.
	E4: FRONTFACE	Front face masking	Contact BEA Technical Support.
			Remove blue protection film.
			Ensure the cover is either completely removed or latched in the closed position.
			Clean the sensor lens with appropriate material.
			Check for frost/ice on te lens. Use Heating function, if necessary.
			Ensure no object (goal post, low ceiling, etc.) is obstructing the sensor view.

# BEA LZR Widescan

DE# 10-00-732

E5 		The sensor requires a teach-in	Launch teach-in after angle adjustment. All presence/safety outputs are activated.
	E5: INSTALL	Install teach-in is required after power-on, curtain disabling, or factory reset	Launch a teach-in.
	E5: FLATNESS	Faulty teach-in because the sample area is not flat	<ol style="list-style-type: none"> <li>1. Make sure that the teach-in zone is clear of objects.</li> <li>2. Make sure that any drains/washouts (i.e. holes) are covered with cardboard.</li> <li>3. Launch an install teach-in. Or launch an Install Right or Install Left teach-in if objects are permanent and unmovable, yet still obstructing a successful teach-in.</li> </ol>
	E5: MASKING	A portion of the sensor's view is blocked during the Install Teach-in	<ol style="list-style-type: none"> <li>1. Determine if the masked area will affect sensor performance (think "If I can't see it, it can't see me").</li> <li>2. Walk-test the patterns to ensure good detection and operation.</li> </ol>
	E5: TILT	Faulty teach-in due to tilt angle (i.e. tilted too far away from or too close to the door)	<ol style="list-style-type: none"> <li>1. Adjust tilt angle (Diagnostics menu in LCD). Note: max. 15°</li> <li>2. Launch an install teach-in.</li> </ol> <p>Change Force Tilt from "auto" to "manual."</p>
	E5: AZIMUTH	Faulty teach-in due to lateral angle (i.e. rotated too far clockwise or counter-clockwise on the bracket)	<ol style="list-style-type: none"> <li>1. Adjust lateral angle (Diagnostics menu in LCD). Note: max. 45°</li> </ol> <p>Launch an install teach-in.</p> <p>Change Force Azimuth from "auto" to "manual."</p>
	E5: HEIGHT	Faulty teach-in due to mounting height	<p>Adjust mounting height (max. 32', min. 6'6").</p> <p>Launch install teach-in.</p>
E5 	E5: TIME-OUT	Fault teach-in	<p>Relaunch install teach-in. Make sure that there is no motion detection during at least 5 seconds when LED starts flashing red/green.</p> <p>Slightly change your position and relaunch an install teach-in.</p>
	E5: FORCED	Tilt angle, azimuth angle, or height has been manipulated	Nothing; this is a notification that the tilt angle, azimuth angle, or height has not been automatically calculated by the sensor.
E6 	E6: FQ OUT	Faulty sensor output 1	Replace sensor.
E8 	E8: ...	Faulty detection engine	Cycle power. If error returns, replace sensor.
	Solid ORANGE LED remains on	The sensor encounters a memory problem	Replace sensor.
 3 sec	ORANGE LED is on for 3 sec. (masking)	Sensor placed in a corner and perpendicular to a wall	Tilt sensor to shift detection field. Ignore warning:  
		Masking: obstacle high up in front of door	Reduce number of curtains (QUICK START > MORE > Nb curtains). Ignore warning:  
Door does not react	Service mode is activated		Exit service mode (see page 9).
	Incorrect outputs (if occurring in Motion field, it is likely that Motion+Height is selected)		Check output functions and adjust accordingly.
	Incorrect wiring		Verify wiring.
	Incorrect door control programming		Contact door manufacturer.
Sensor does not react to remote control	Sensor is password-protected		Enter correct password. If you forgot the code, cut and restore power supply in order to access the sensor without entering a password during 1 minute.
Motion detection starts too late	Negative angle is too large		Reduce angle of the sensor.

# Red and Green LED Light Strips

## DE# 10-00-993/994/995



### 6.1 Required Parts for Installation Per Opening

- QTY (2) **10-00-993** LED 5FT Light Kit Retainer Track
- QTY (1) **10-00-994** LED 5FT Light Kit LED Strip
- QTY (2) **10-00-995** LED 5FT Light Kit 20FT Cable Harness

### 6.2 Mounting the LED Retainer Track

Peel off the adhesive backing on the LED Retainer Track.

Mount one 5-foot section on each leading edge of the door, directly onto the safety edge standoff.

*Note:* Mounting height is based on installer preference; Door Engineering's standard is **4 feet from the ground**.

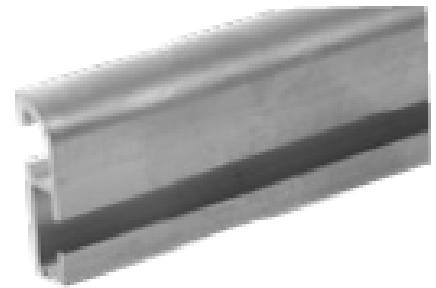

### 6.3 Preparing for Wiring

Drill a small hole in the aluminum mounting channel of the safety edge to allow the LED wiring to pass through, just above the LED Retainer Track.



# Red and Green LED Light Strips

## 6.4 Installing the LED Strip

Slide the LED light strip into the mounted retainer track, ensuring the wire tail is positioned at the top.

## 6.5 Routing the LED Cable Harness

Run the 20-foot LED cable harness through the aluminum safety edge standoff and connect it to the LED strip.

Pull the excess cable to the top of the door and route it through the D-Line raceway, alongside the safety edge wiring.



## 6.6 Wiring the LED Lights to the Control Panel

LED Light Wire	Connect To
Black	24H
Green	Control Panel Terminal 242
Red	Control Panel Terminal 285 265
	Control Panel Terminals Jumper 241 to 24N & 284 to 24N & 264 to 24N

## 6.7 PLC Programming Settings

### Output 5 Configuration Options:

- Program 0** (Factory Default): Constant signal during door closing – Close Warning.
- Program 1**: Flashing signal during both opening and closing – Open/Close Warning.

# Troubleshooting

## Doors not Operating

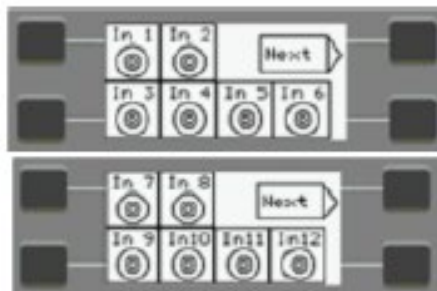
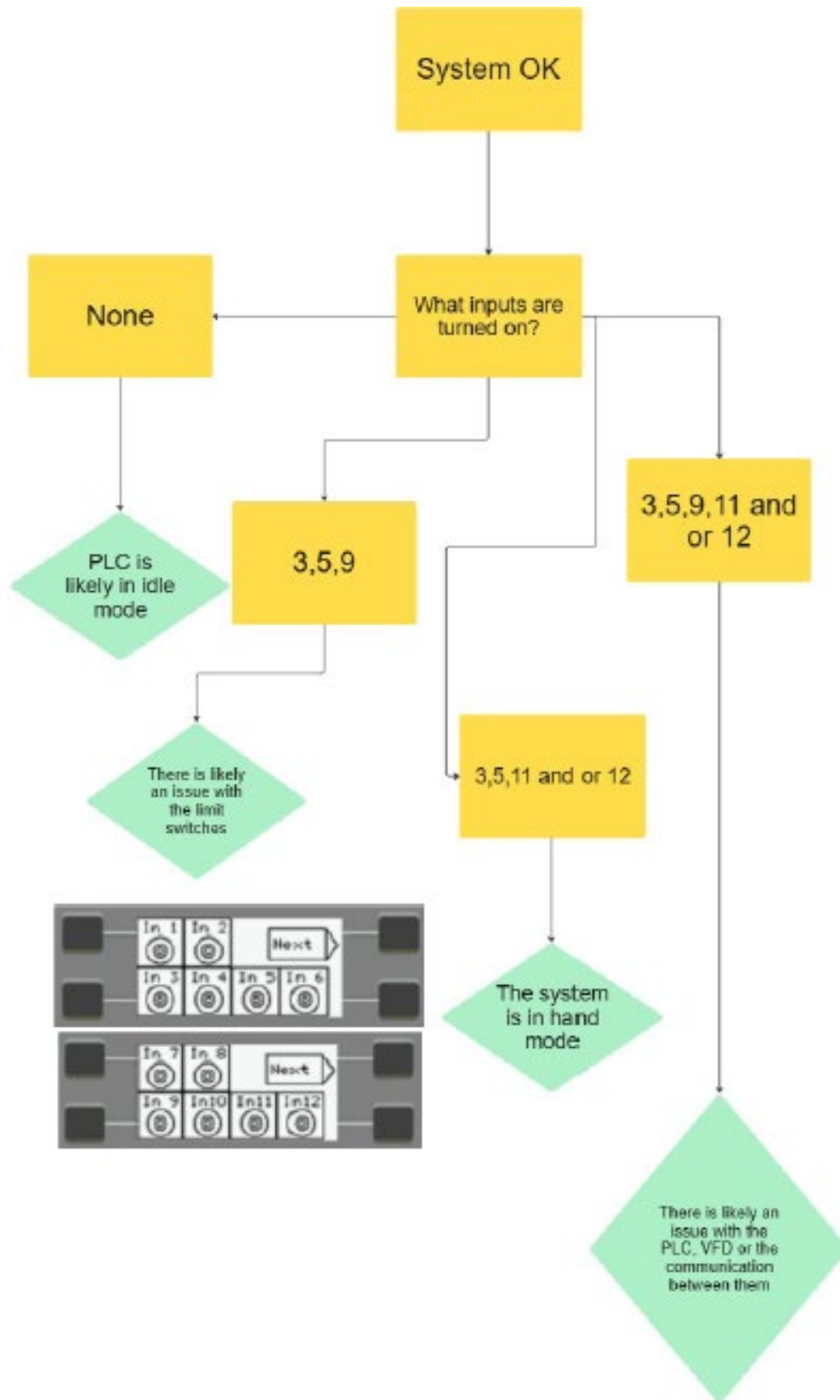

# Troubleshooting

## Stop PB Error

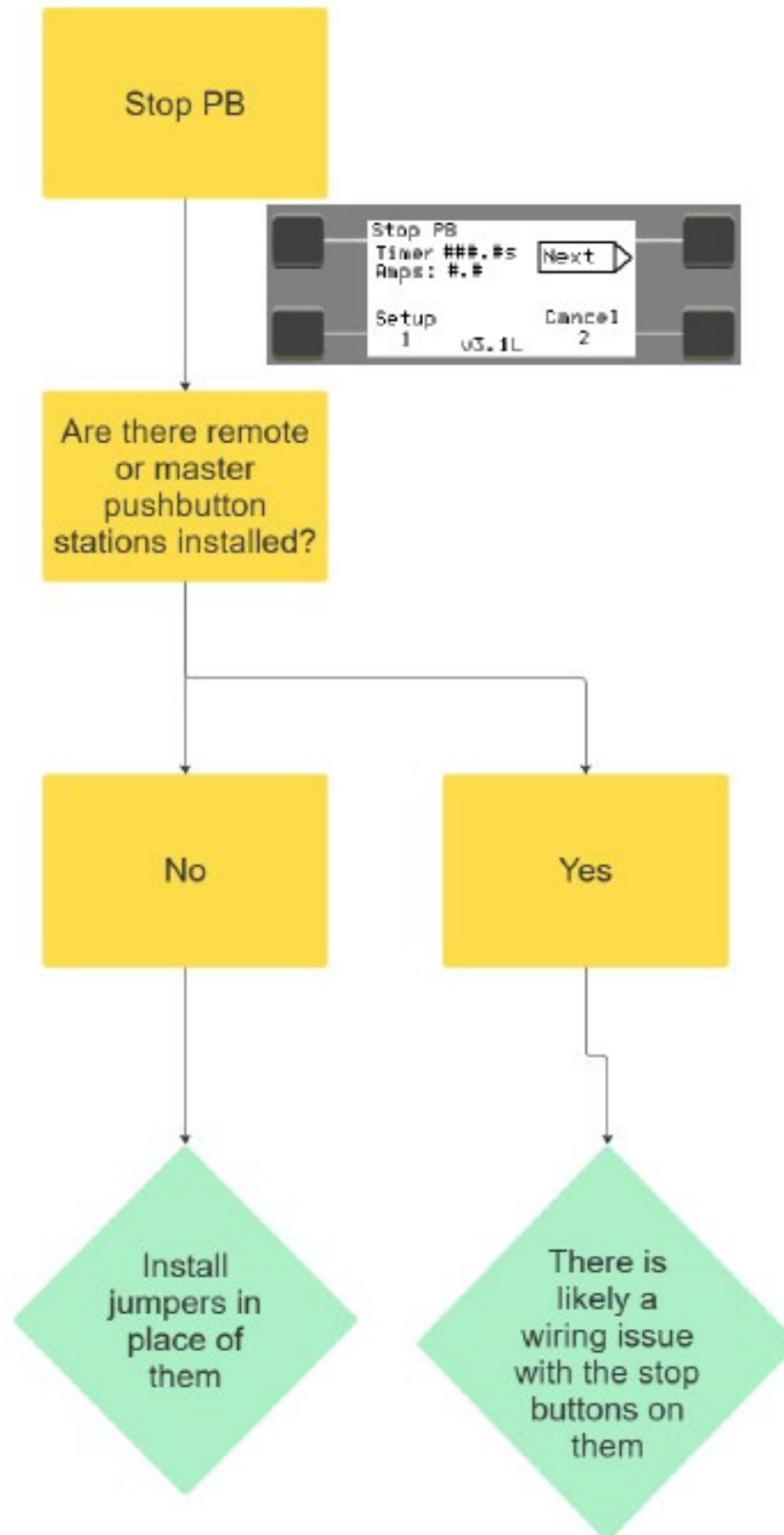

# Troubleshooting

## Motor Timeout

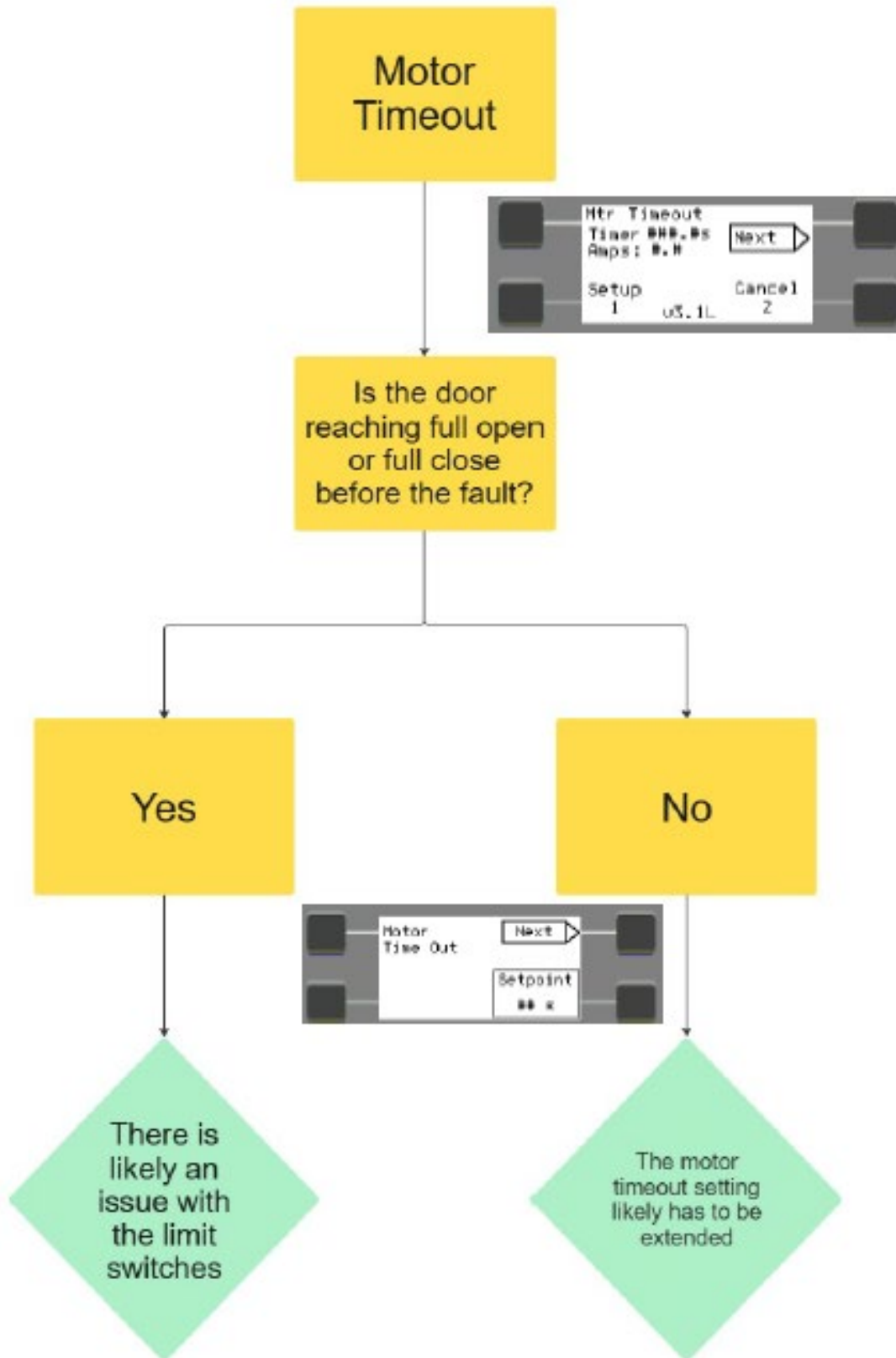

# Troubleshooting

## Motor Overload

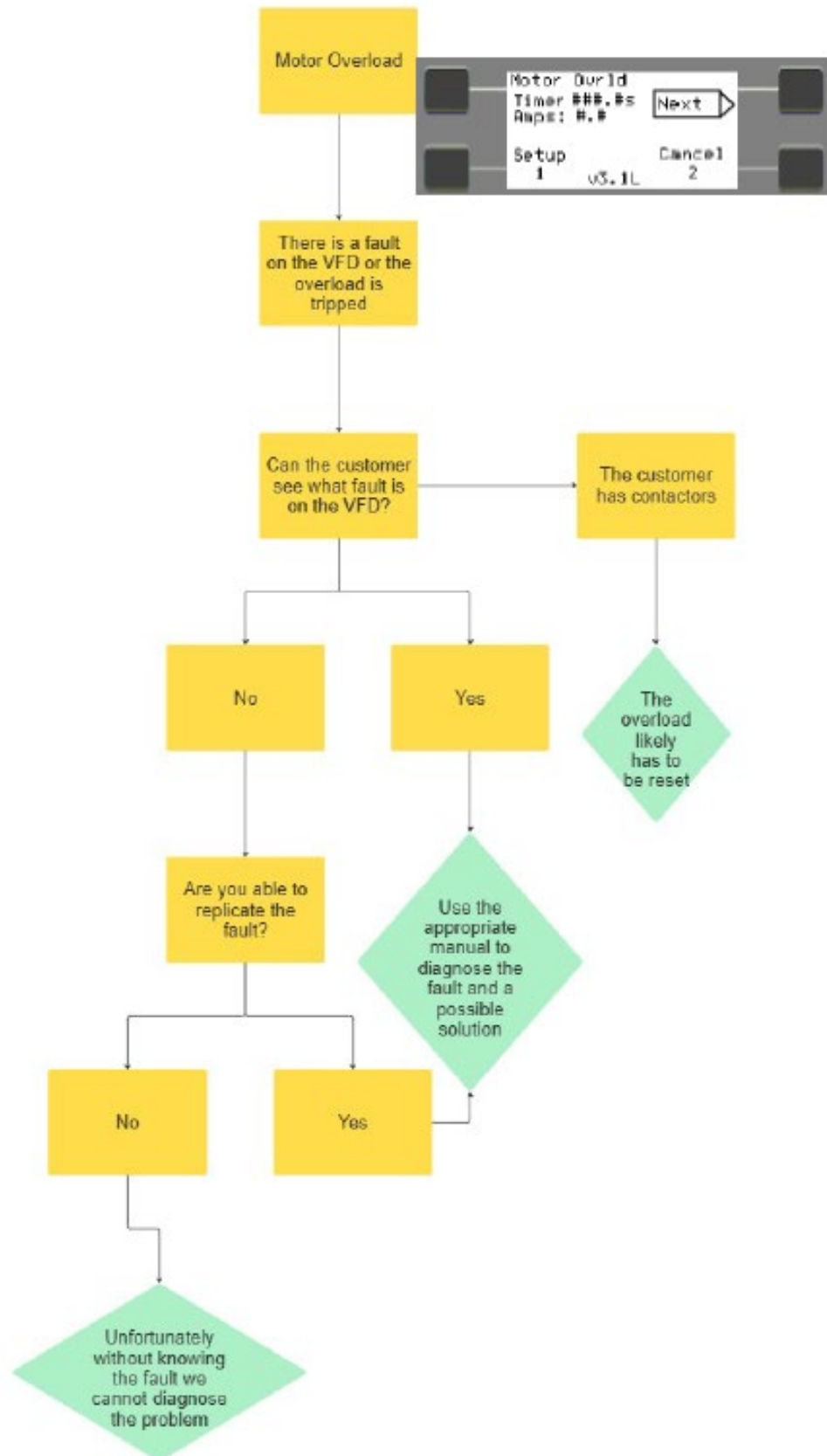

# Troubleshooting

## Exterior Sensor Error

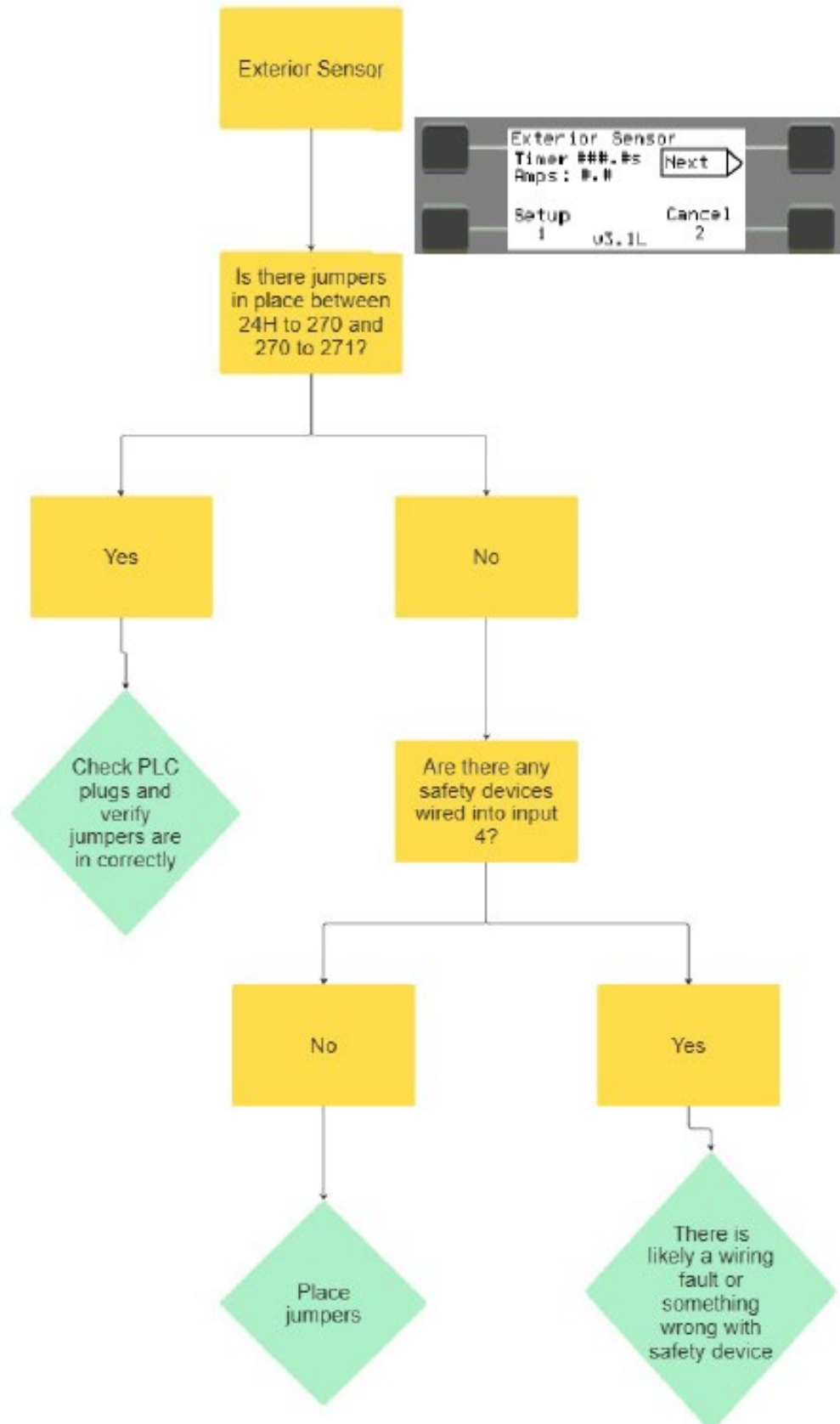

# Troubleshooting

## Interior Sensor Error

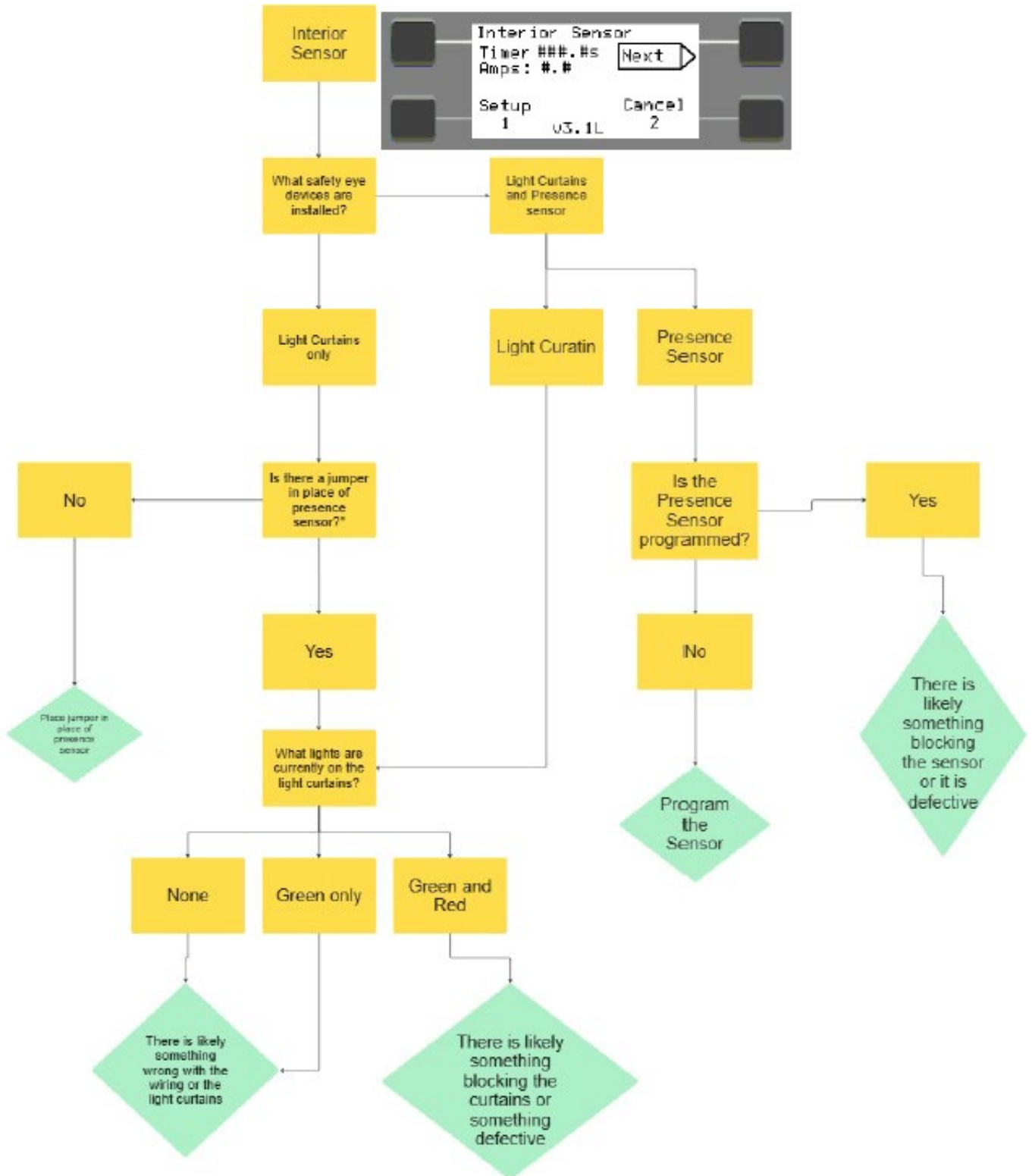

# Troubleshooting

## Aux Open

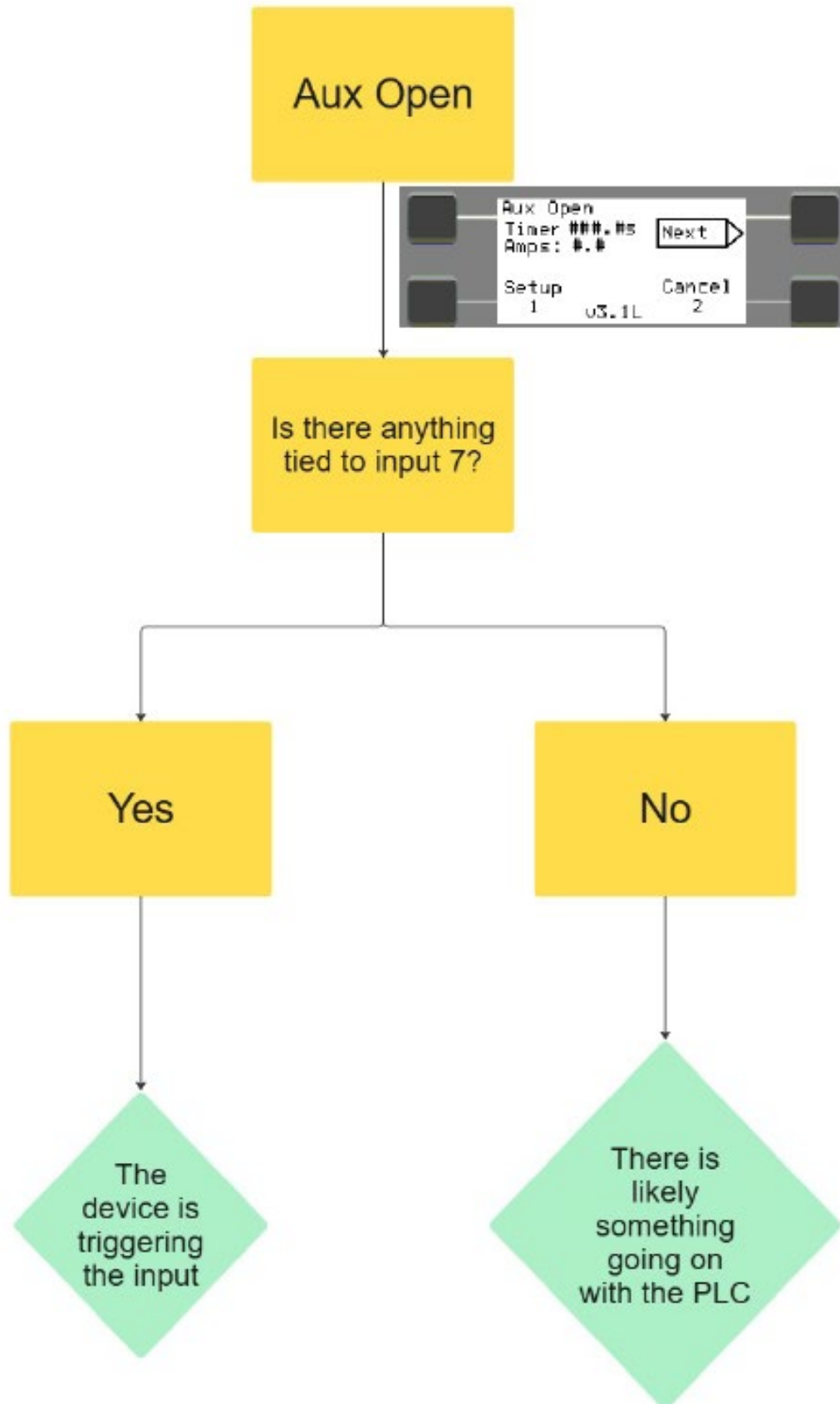

# Troubleshooting

## Safety Edge Error

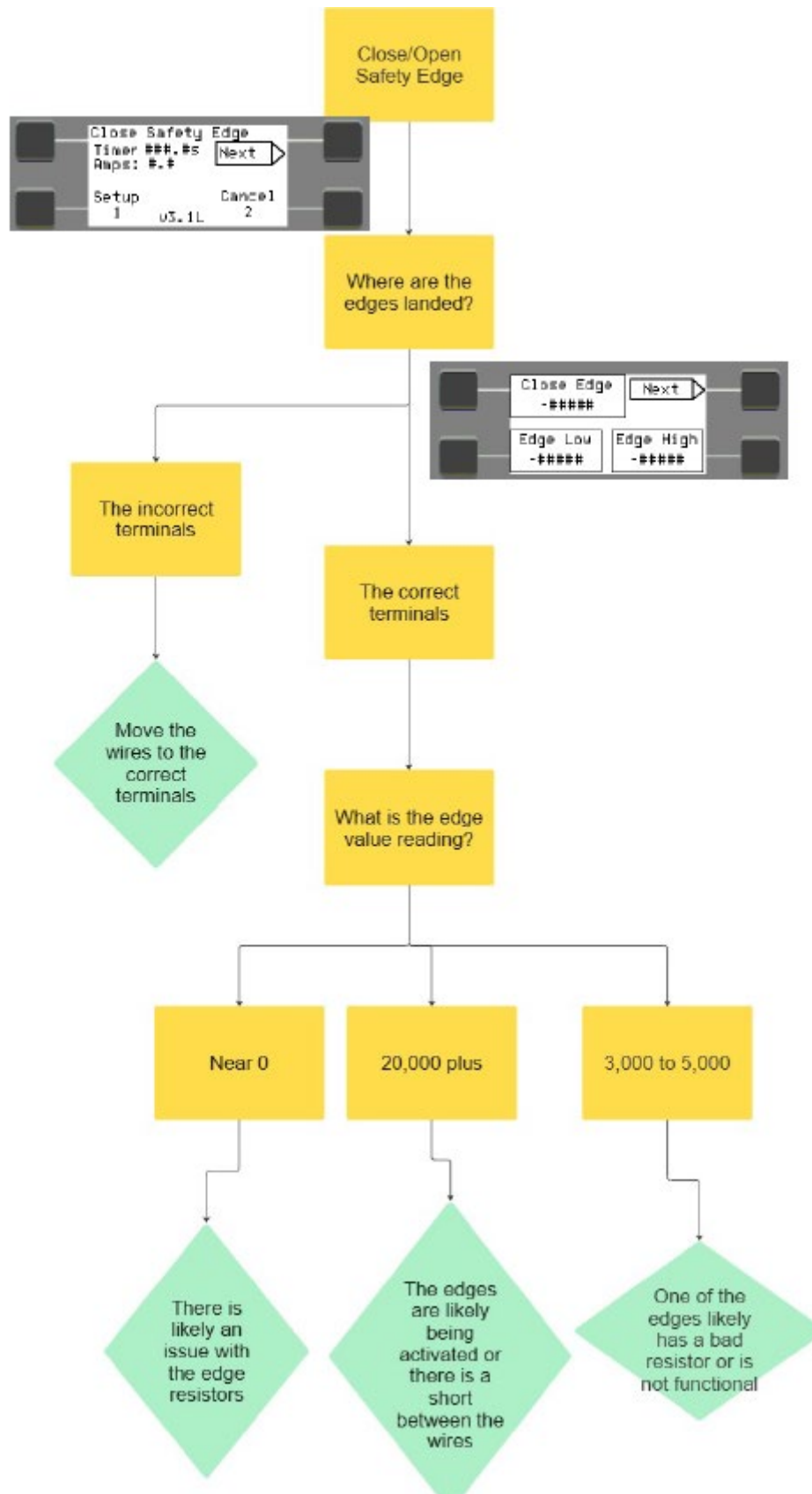

# Troubleshooting

## Loop Detector

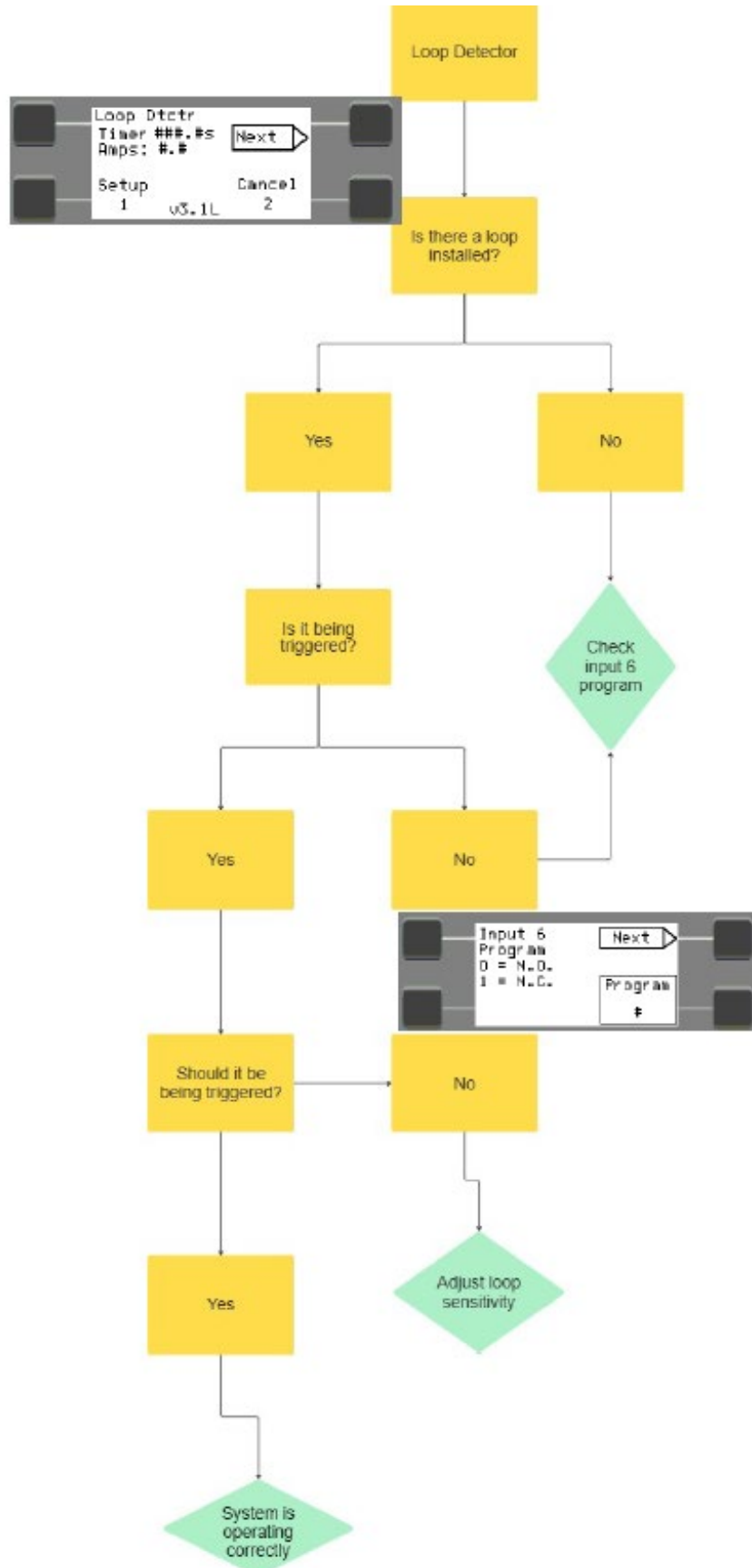

 **WARNING****To reduce the risk of SEVERE INJURY or DEATH to persons or damage to the door system**

- Safety precautions should be followed at all times.
- All electrical wiring must be done by a certified professional and performed according to regional electrical codes.
- When servicing, always disconnect Operator from main power supply.
- When servicing, always ensure proper use of “Lockout/Tagout” procedures.
- Ensure use of proper wire gauge being used for incoming power line as well as for all device connections.
- Install operator main circuit breaker next to control panel for easy power shut-off.
- The cord fitting for main power cable coming into control panel shall be separate from the motor or any other device.
- Always separate low and high voltage wires in separate conduits. High voltage frequencies may interfere with low voltage wires.
- The Operator should be properly grounded to the building ground and to the main power supply ground lug.
- Always use the appropriate rating circuit breakers for Operator protection.
- Before electrical connection, compare the incoming power supply voltage to the voltage on the Control Panel name plate. Failure to connect appropriate power supply voltage may cause serious damage to the Operator.
- Inspections, service, and repairs should be performed anytime a malfunction is observed or suspected.
- Only qualified persons should perform maintenance on a Door Operator and all safety precautions should be taken into consideration.
- Do not manually disconnect Connecting Rods unless power has been electrically disconnected.
- Do not attempt to disconnect Connecting Rods with the door in the open position.
- Do not attempt to make Limit Switch adjustments unless power has been electrically disconnected.
- Always test the door travel after adjustment with the controls in “Constant Pressure” mode to verify desired travel. Failure to do so may result in damage to the door or injury to persons.











Opening to Your Standards