

FOUR-FOLD



FF300/FF701

INSTALLATION INSTRUCTIONS



DoorEngineering.com
800.959.1352



Table of Contents

Important Notice	3
Before Door Installation	3
Before Operator Installation	3
Operator Install	3
Safety Practices	3
Check the Shipment	4
Loading and Installation Equipment	4
FF300 Interior Parts Guide	5
FF300 Exterior Parts Guide	6
Required PPE	7
Installation Instructions	8-24
STEP 1: Door Preparation	8
STEP 2: Removing Panels From Shipping Rack	9-10
STEP 3: Lifting Panels	10-11
STEP 4: Mounting Jambs	12
STEP 5: Mounting Header	12
STEP 6: Securing Jambs and Header	12
STEP 7: Installing Track and Trolley's	13-14
STEP 8: Panel Adjustment	15
STEP 9: Control Arm Installation	16
STEP 10: Operator Installation	16-17
STEP 11: Connecting Rods Installation	18
STEP 12: Weathering Installation	19
STEP 13: Pull Handle Installation	19
STEP 14: Window Installation	20
STEP 15: Manual Operated Doors	22
STEP 16: Hinge Guard Installation	22
STEP 17: Safety Labels Installation	23
STEP 18: Applying Finishing Touches	24
Additional Hurricane Installation Instructions	25-27
STEP 1: Cremona Keepers For FF701 Doors	25
STEP 2: Hurricane Astragal Installation	26-27
Optional Equipment	28-29
STEP 1: Floor Guides	28
STEP 2: Throttle Cable Installation	29
Alternative Operator Installation Instructions	30-35
STEP 1: Dual Operator Installation	30
STEP 2: FF300 Exterior Operator Installation	31-32
STEP 3: Side Mounted Hydraulic Operator Installation	33-35
Appendix: R1 Operator Layout	37-38
Appendix: R2 Operator Layout	39-40
Appendix: R3 Operator Layout	41-42
Appendix: R3.5 Operator Layout	43
Appendix: XT Operator Layout	44-45
WARNING	46
Limited Warranty	47-49
NOTES	50-51

WARNING

Before Door Installation:

- **READ AND FOLLOW ALL INSTALLATION INSTRUCTIONS.** Review with installation team.
- Verify required documents are correct (as built and E1, Operator Layout, etc.)
- Verify that installation equipment (Telehandler, Forklift, Crane, etc.) is rated to handle the weight of the door.
- Verify that the door is the correct size for the opening. Measure and inspect the openings width and dimensions (reference included as-built drawings).
- Ensure that work area is clear of dirt and debris.

Before Operator Installation:

- **ALL ELECTRICAL WIRING MUST BE DONE BY A CERTIFIED ELECTRICIAN.**
- Read the *CW Automation Door Controller Setup Manual SueMax Guide* provided with the control panel.
- Refer to all applicable local electrical codes.
- Always refer to National Electric Code.
- Always disconnect Main Power before doing any electrical work.
- Verify that proper Over-Current and Short-Circuit prevention will be used.
- CW Automation Contact: (507)-665-4186

Operator Install:

- A door that is operating improperly could cause severe injury. Have qualified service personnel make repairs or adjustments to panels and other hardware before installing the Operator.
- Place and constrain door panels in the closed position **before** connecting Operator.
- Installation of door Operator must be done by a qualified installer.
- Do not connect the Door Operator to the source of power until indicated in the instructions.
- Locate the Control Panel:
 - In sight of door system
 - Away from all moving parts of door system

Safety Practices:

- All labels are provided in the “Safety Label Kit”.
- Install the “Entrapment Warning” label next to the Control Station in a prominent location.
- Before operating, always check clearance around the door for any person or object that may be in the door(s)’s path. Never store items in or near the area of door travel.
- If you have any questions about the safety of the door operating system. Contact Door Engineering & Manufacturing at **1-800-959-1352**.

Check The Shipment

It's very important before installing the doors to check for any shipping damages or missing items immediately upon arrival. Go through the shipping list and check off all the hardware parts specified in your order. The shipping list is in the hardware crate with the installation instructions and as built drawings. If any equipment, doors, or hardware is missing or damaged, call Door Engineering immediately at **1-800-959-1352**.

Loading and Installation Equipment

Forklift Installation Tool (Fig. 1)

- **DE Part # 1-85-020**
- Load Capacity 1,600 lbs.



Install slings (NOT INCLUDED) (Fig. 2)

- Load Capacity 1,600 lbs. (basket load)
- Recommend one 10 ft. or two 8' twisted-eye web slings.



Installation Bracket (Fig. 3)

- **DE Part # 1-85-013**
- Load Capacity 2,100 lbs.

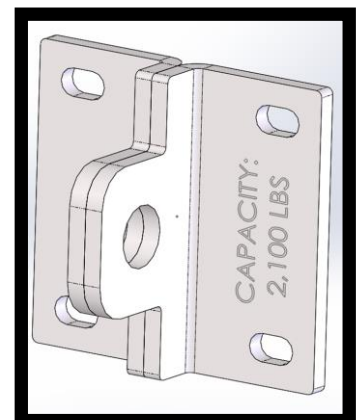

NOTE: DO NOT ATTEMPT TO LIFT LOADS THAT EXCEED INSTALLATION TOOL CAPACITY. FAILURE TO COMPLY MAY RESULT IN DAMAGE TO DOOR AND/OR FACILITY, BODILY HARM, OR DEATH.

FF300 Interior Parts Guide

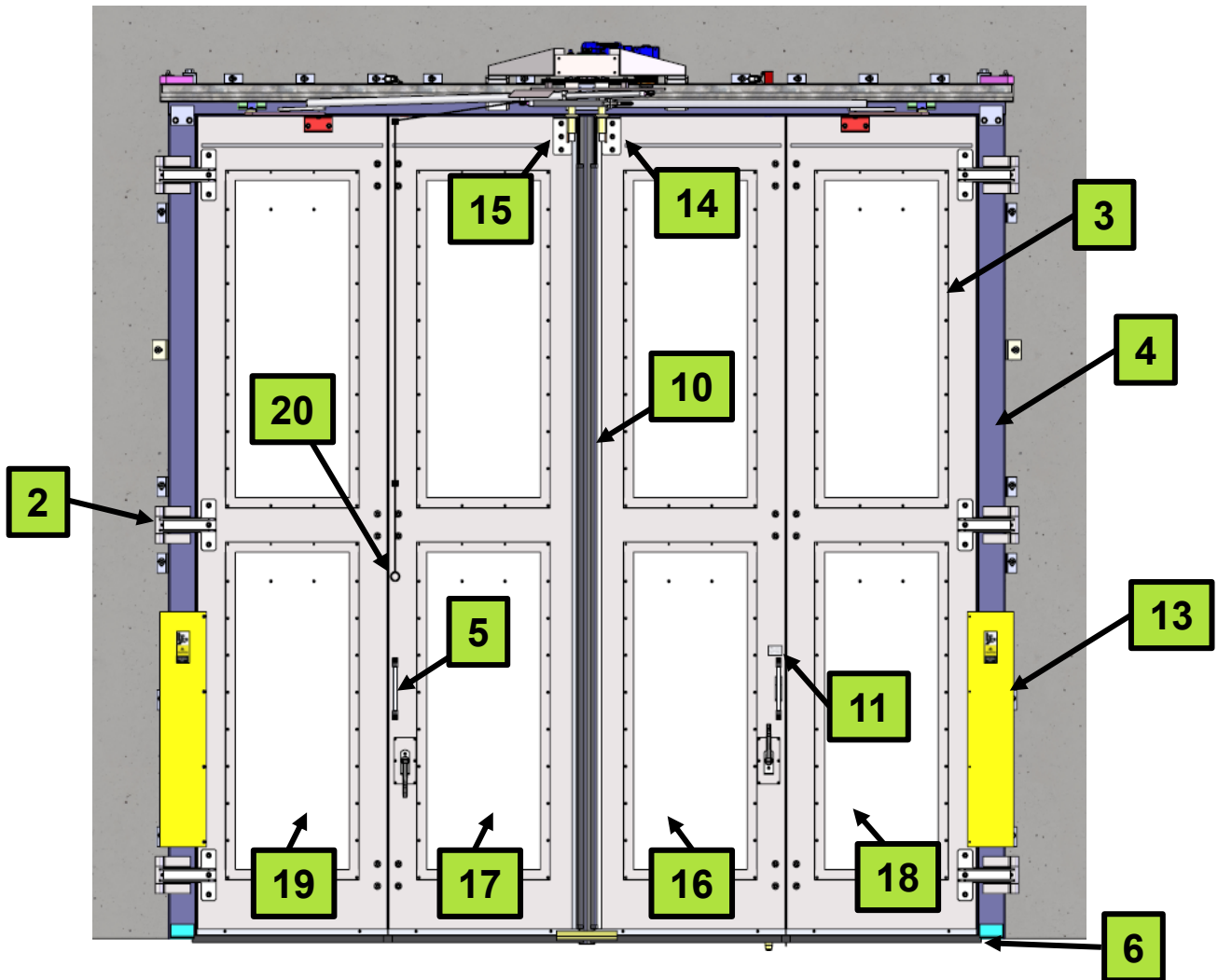
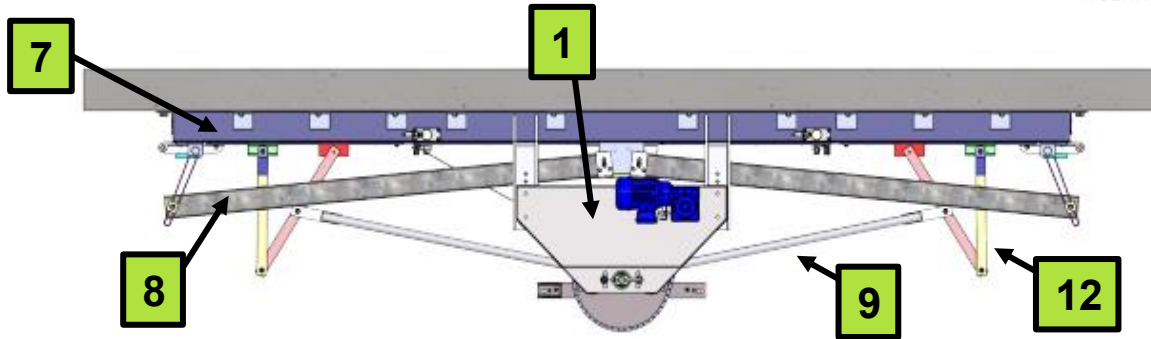

- | | | |
|-------------------|---------------------------------|----------------------|
| 1. Operator | 8. HV1 Track | 14. RH Trolley |
| 2. Jamb Hinge | 9. Connecting Rod | 15. LH Trolley |
| 3. Window Frame | 10. Safety Edge Assembly | 16. RH Fold Panel |
| 4. Jamb Tube | 11. Door Engineering Serial Tag | 17. LH Fold Panel |
| 5. Pull Handle | 12. Control Arm Assembly | 18. RH Jamb Panel |
| 6. Sweep Assembly | 13. Hinge Guard | 19. LH Jamb Panel |
| 7. Header | | 20. Disconnect Cable |

FF300 Exterior Parts Guide

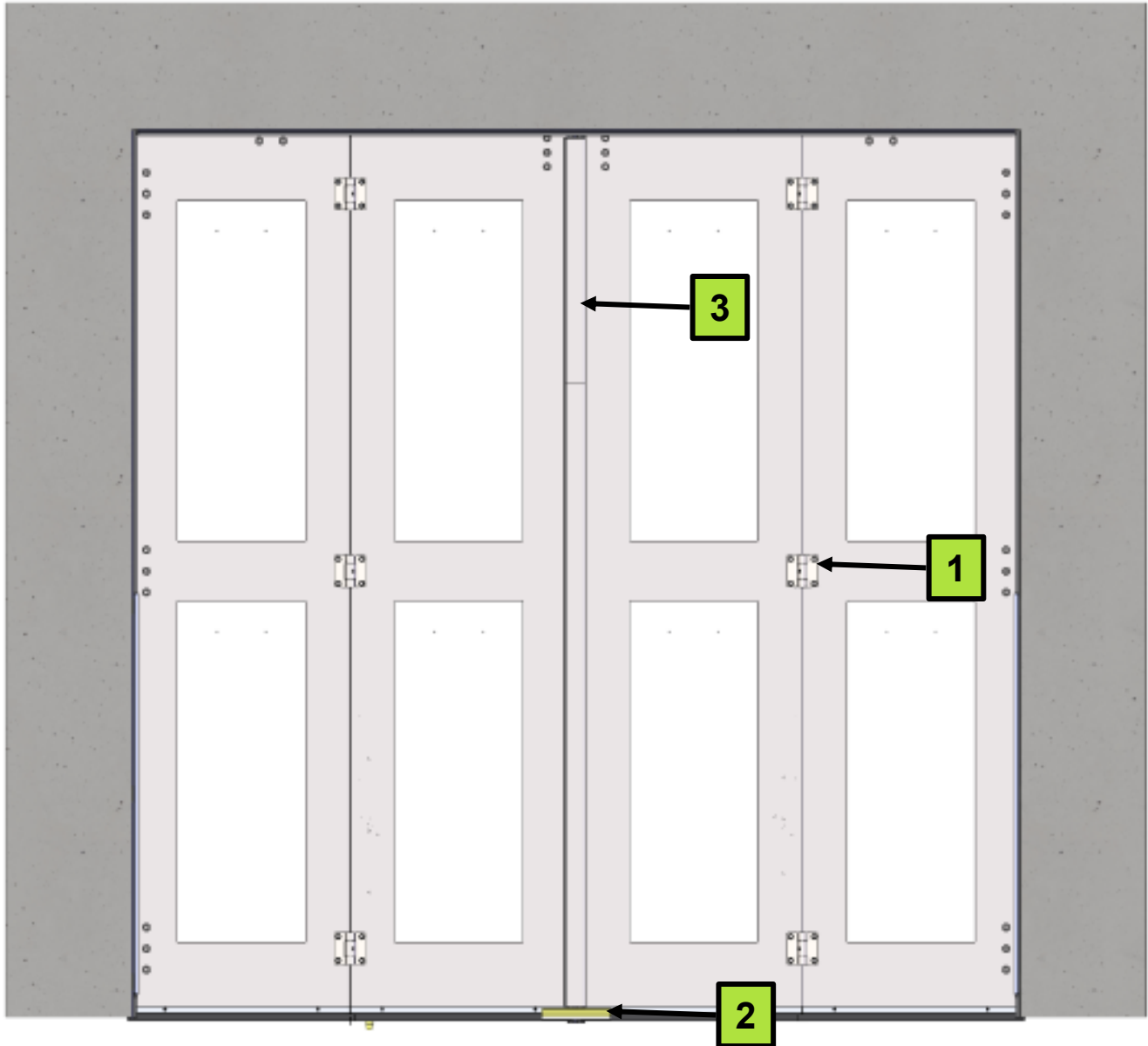

- 1. Fold Hinge
- 2. Floor Guide
- 3. Astragal

Required PPE

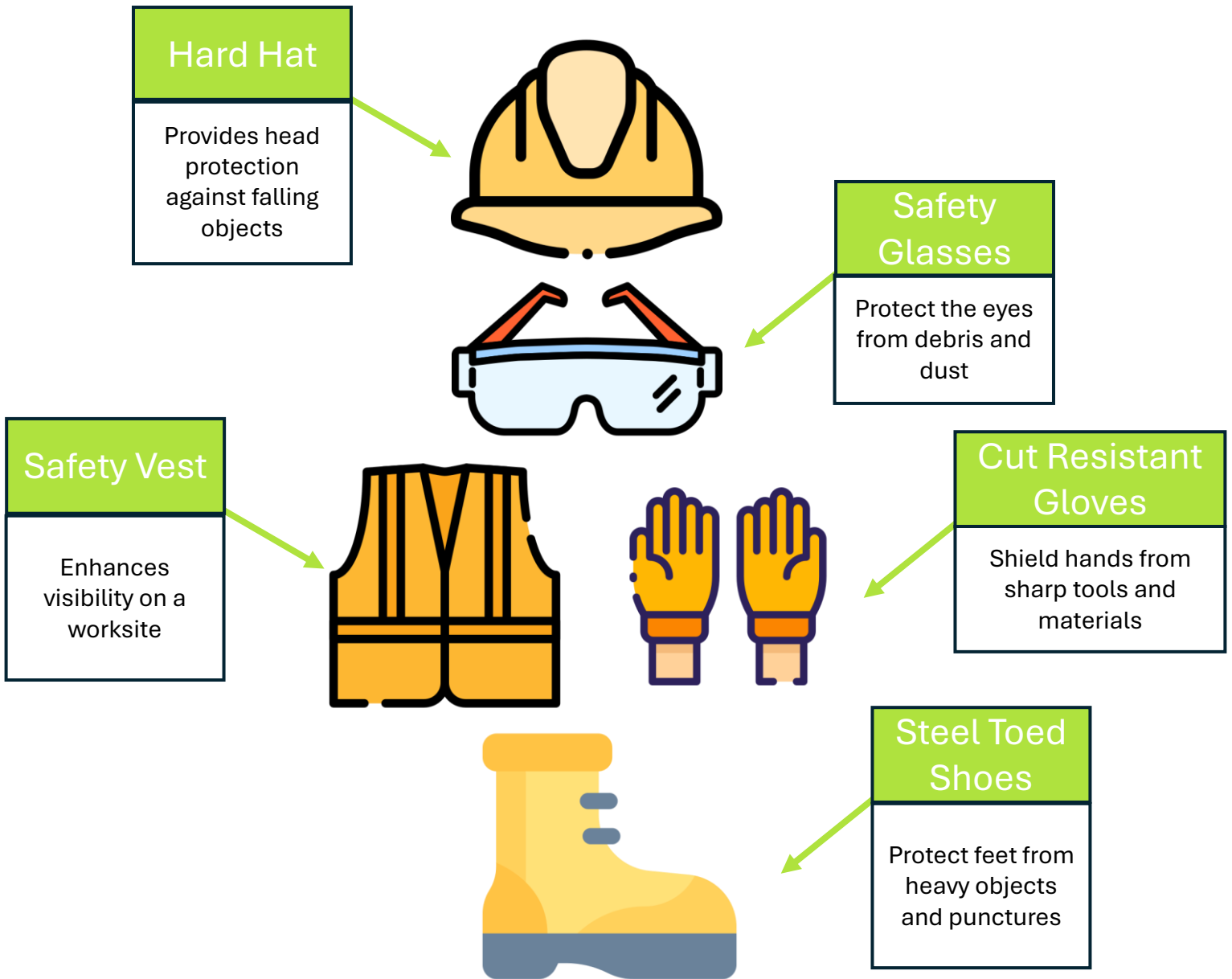

PPE requirements are determined by the individual jobsite and task being performed. The PPE shown represents the minimum basic PPE requirement for industrial door install.

Installation Instructions

STEP 1: Door Preparation

1.1 Preparation The Four-fold door is assembled at the factory as complete as possible to minimize field installation time. The panels have the following items factory installed.

- Hinges
- Safety edges
- Center Bulb Seal
- Jamb Tubes
- Glass (May be factory installed or shipped separately)

Holes are pre-drilled for hardware to be field installed. For easier movement during installation, it is recommended that the panels remain banded together.

Recommended Installation Equipment:

- Lull / Forklift / Boom-Lift / Scissor-Lift
- Blocking / Dunnage
- Lifting Slings (*assorted lengths*)
- Clevis(s)/ Shackles
- Hammer Drill
- Level / Laser Level
- Poly or Steel Shims
- Towels / Rubber Pad (*to protect finish paint*)



1.2 Inspect Opening

- Verify rough opening
 - Width, height, plumb, level (floor/ header), mounting surface, material condition.
 - Mark the center of opening using floor chalk
 - If floor is **not** level, start door installation at higher side of opening

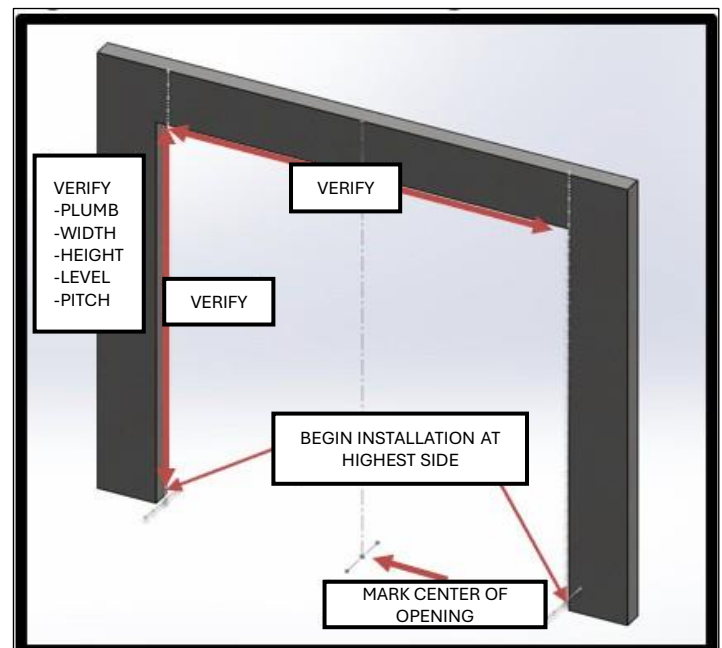

Installation Instructions

Step 2: Removing Panels From Shipping Rack

2.1 Position Rack

- Position Rack where it is accessible from both sides.
- **DO NOT** move rack once banding is cut. Damage to doors may occur.

2.2 Secure Panels for Lifting

- Apply lifting strap directly over the nylon banding at bottom of a half opening door to secure panels together for lifting. (**Do not rely only on nylon banding**)
- Attach the other end of sling to the forklift for lifting.

2.3 Cut Shipping Bands

- Raise forks to lift the slings
- Once tension is applied to the slings, cut panel specific nylon band that secures panels to the shipping rack.

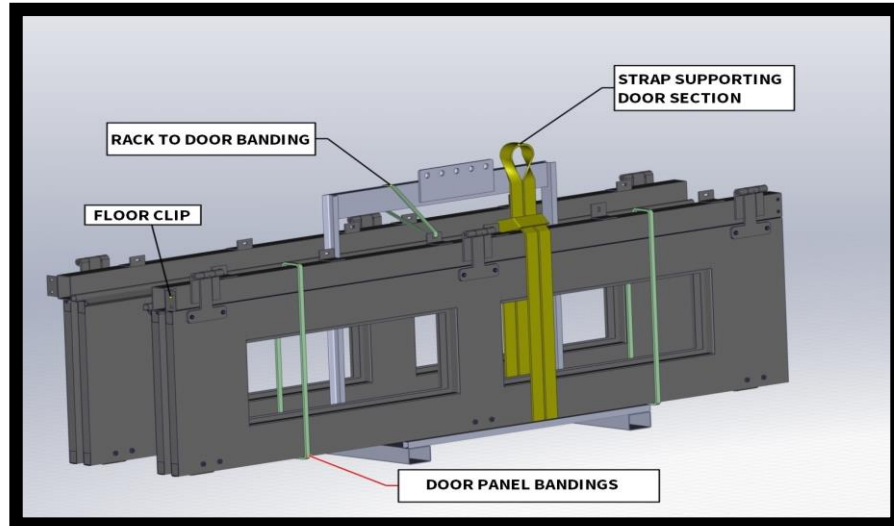

LIFTING FROM FOLD PANEL MAY CAUSE DAMAGE TO SAFETY EDGE.



DO NOT STRAP THROUGH WINDOW FRAMES. LARGER DOORS MAY REQUIRE TWO STRAPS, REFER TO DRAWINGS AND STRAP LOAD RATINGS TO DETERMINE REQUIRED NUMBER



ONLY CUT BANDS ONCE STRAPS ARE IN TENSION



Installation Instructions

2.5 Set Panels on Floor

- Lay padded supports on the floor in front of the half door opening (**minimum height of 6" from floor**) to protect finish
- Position bottom of panels facing the opening and carefully lay the panels onto wood padding.
- **Do NOT remove the wood padding or banding from the panels until it is fully resting on padding**



Step 3: Lifting Panels

3.1 Panel Preparation

- Remove the bands securing the door. Install a sling going through a single panel and attach to the forklift. Ensure the sling routes around the panel by passing through fold gap
- Once the strap is secured, **carefully unfold the panel**
- Make sure the bottom of the door is aligned with the half door opening (Fold Hinge Facing up)
- **DO NOT REMOVE STRAP UNTIL PANELS ARE BEING LIFTED TO THE WALL**

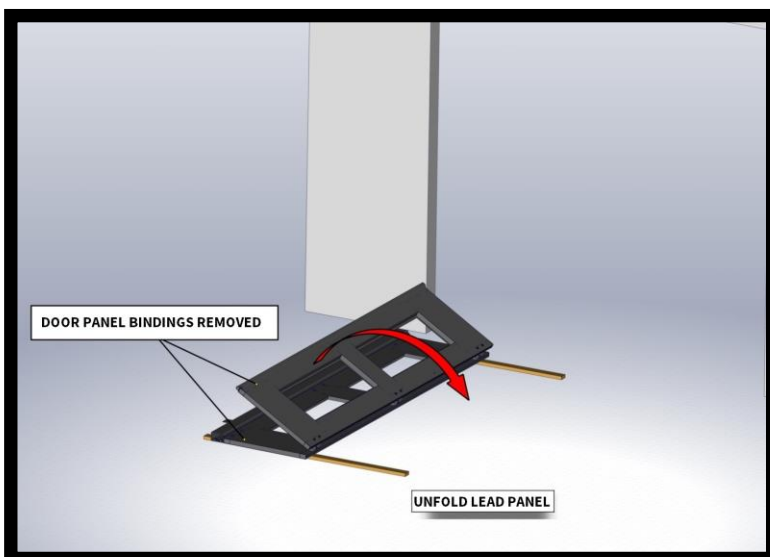

Installation Instructions

3.3 Installation Bracket

- Remove the Top Fold Hinge
- Replace with **installation bracket**

3.4 Connecting Forklift Tool

- Slide the Forklift tool onto the forklift
- Remove front bolt from the forklift tool
- Align forklift tool with the installation bracket
- Reinstall and secure the bolt, ensuring it connects both the tool and bracket properly

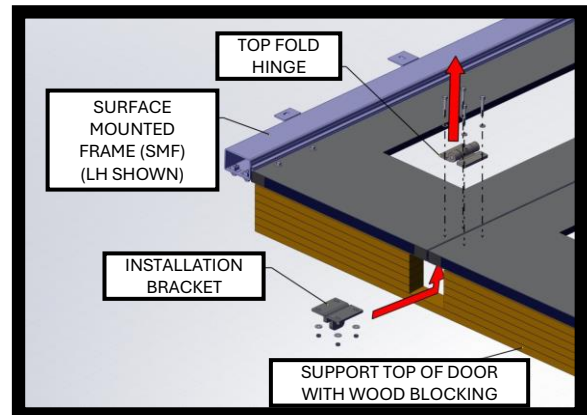

3.5 Protecting Door Bottom

- Block bottom of door using **two pieces of wood**
- Ensure wood protection prevents the **panel and safety edge** from contacting the **ground** during lifting

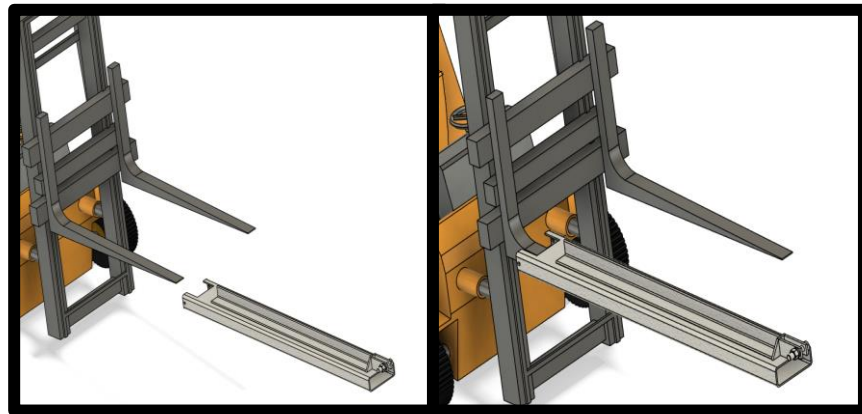

3.6 Lifting Door into Position

- Lift the door as a single assembly
- Maintain controlled movement and proper orientation during lifting



REFERENCE THE DRAWINGS TO CONFIRM THE LOAD RATINGS OF BOTH BRACKET AND INSTALL TOOL WITH DOOR PANEL BEFORE LIFTING



FALIURE TO DO SO WILL RESULT IN DAMAGE SAFETY EDGE AND/OR DAMAGED PAINT.



Installation Instructions

Step 4: Mounting Jamb

4.1 Anchoring Jamb Tubes

- Install **one anchor** at both the **Horizontal Slot** and **Floor clip**



Jamb Tubes Bolting Order

1. Wall
2. Jamb Tubes
3. Anchor Bolt

4.2 Anchoring Opposite Door

- Repeat **Steps 2-4.1** for opposite door half

4.3 Alignment Verification

- Make sure all door sections are **level, centered and flush** across the openings

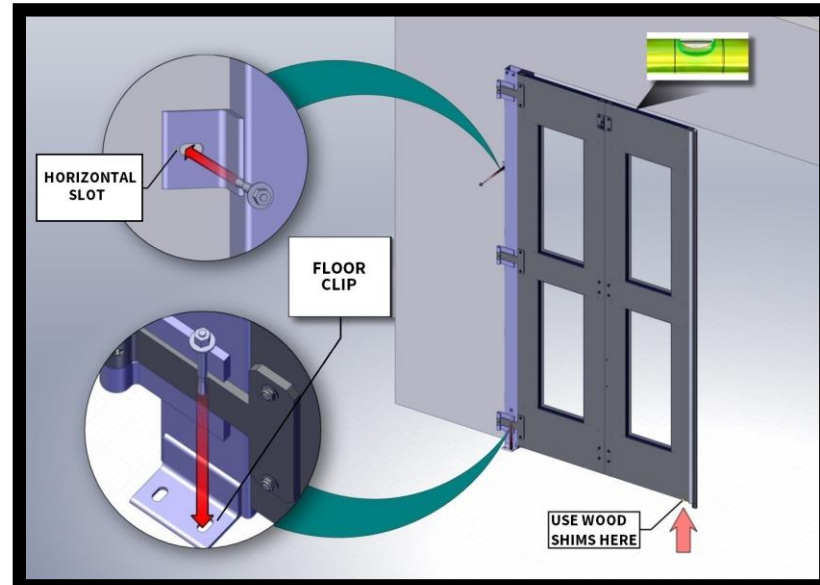

Step 5: Mounting Headers

5.1 Install Header

- Set the headers on top and bolt them to the jamb



Header Bolting Order

1. Wall
2. Header
3. 1/2" Bonded Washer
4. 1/2" x 1.5" Hex Head Bolt

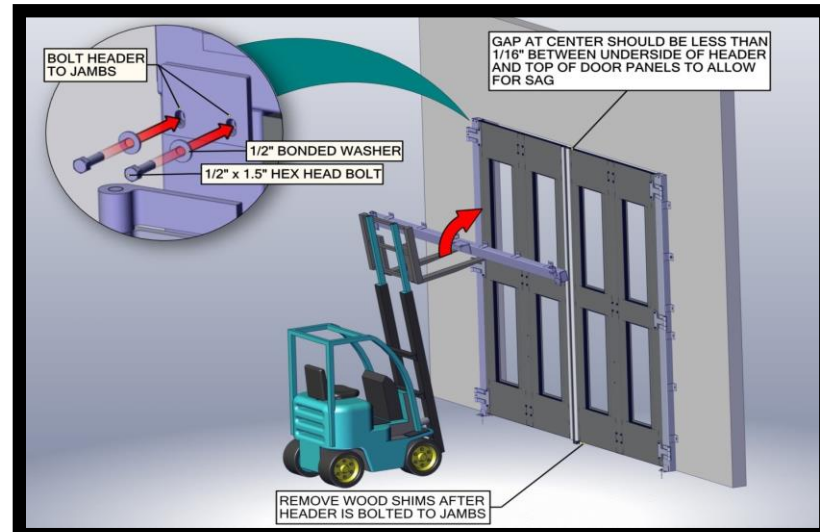

5.2 Shim Header (If needed)

- Place shims vertically if the header and jamb are not plumb to the wall
- Center gap must be less than 1/16" between underside of header at top panels for deflection

Step 6: Securing Jamb and Headers

6.1 Installing Remaining Anchors

- After leveling and shimming, install all remaining anchors on the jamb and header (**See as built for anchor size, Section A-A & C-C**)

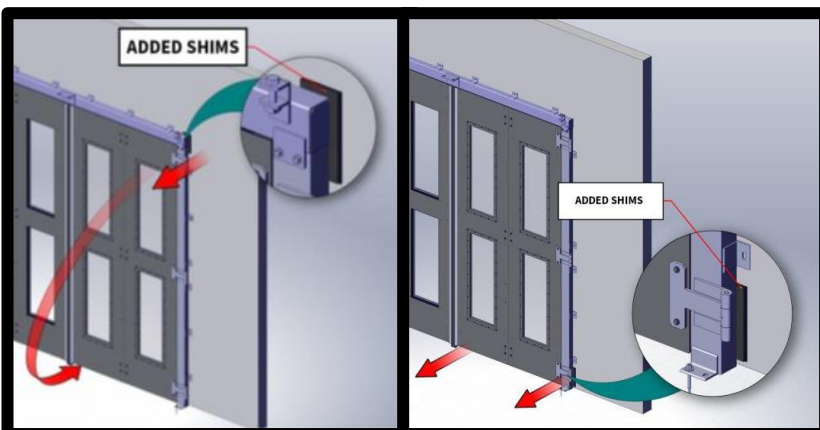

Installation Instructions

Step 7: Installing Track and Trolley's

7.1 Installing Tracks

- Install HV1 track hardware **finger tight**
- **Use Hardware kit per as built drawings**



End Track Bolting Order

1. 5/8" x 2.75" Hex Head Bolt
2. Track
3. End Track Support
4. 2" Square Washer
5. 5/8" Lock Nut



Center Track Bolting Order

1. 5/8" x 1.50" Hex Head Bolt
2. Track
3. Track Center Support
4. 5/8" Flat Washer
5. 5/8" Lock Nut

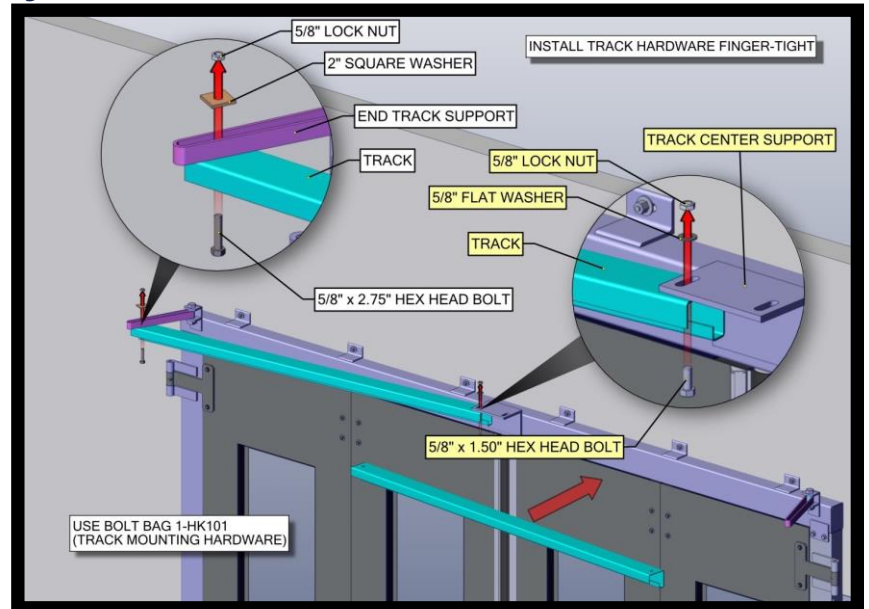

IF APPLICABLE: Install Track Reinforcement (page 27) after step 7.1

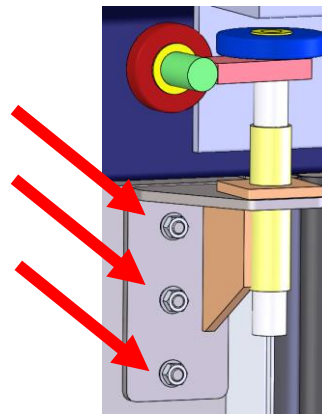

7.2 Installing Trolleys

- Install trolley at the top inner corner of the door panel and secure using provided hardware kit
- Ensure the trolley is **slightly tilted inward** before securing the hardware to provide better clearance

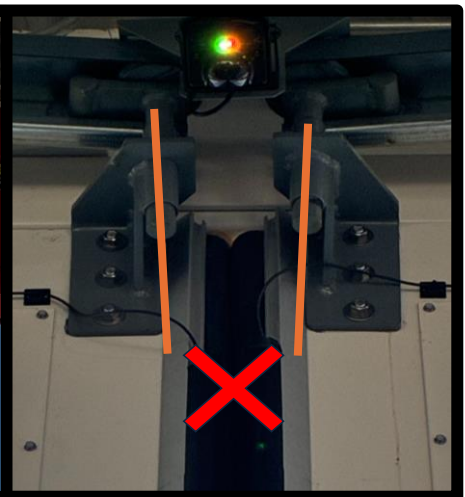
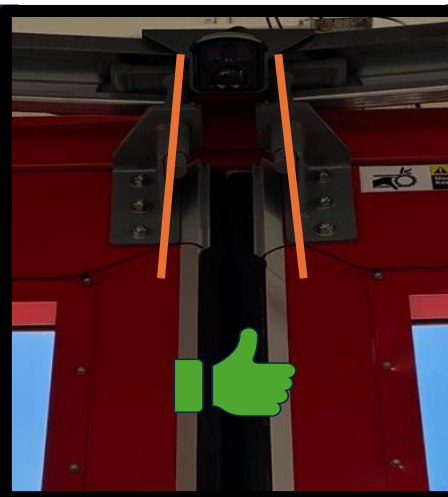

Installation Instructions

7.3 Verifying Door Opening Angle

- Doors should open slightly past 90 degrees for standard door (**approximately 85 degrees between the door and wall**) Reference as built drawings for design intent.

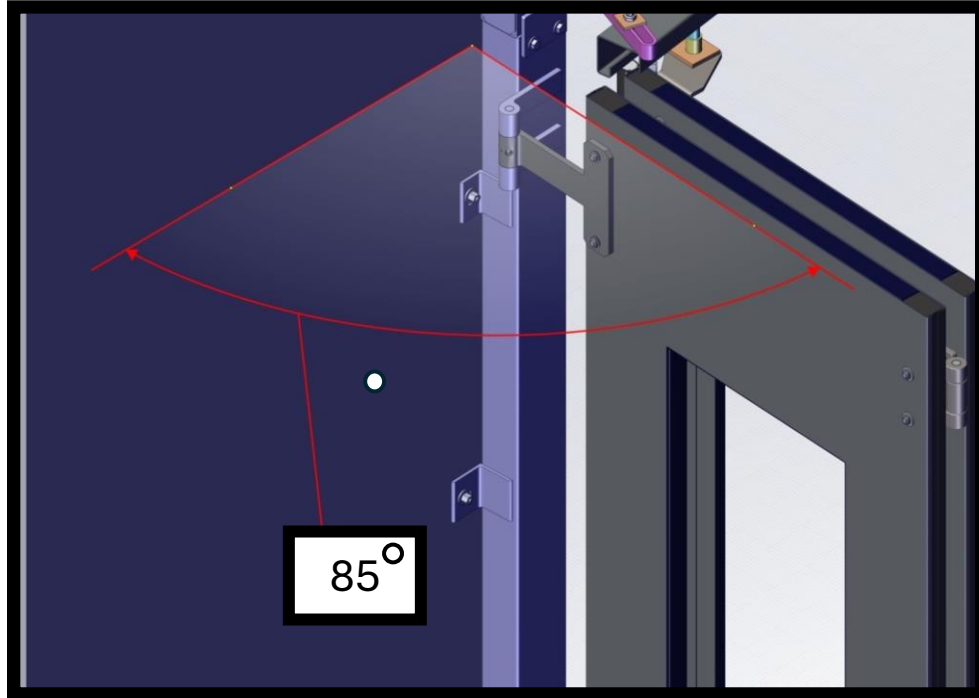

7.4 Verifying Track Position

- Confirm that track is approximately 1.5" from interior edge to center track support located on surface mounted frame
- The mounted frame can also be adjusted later

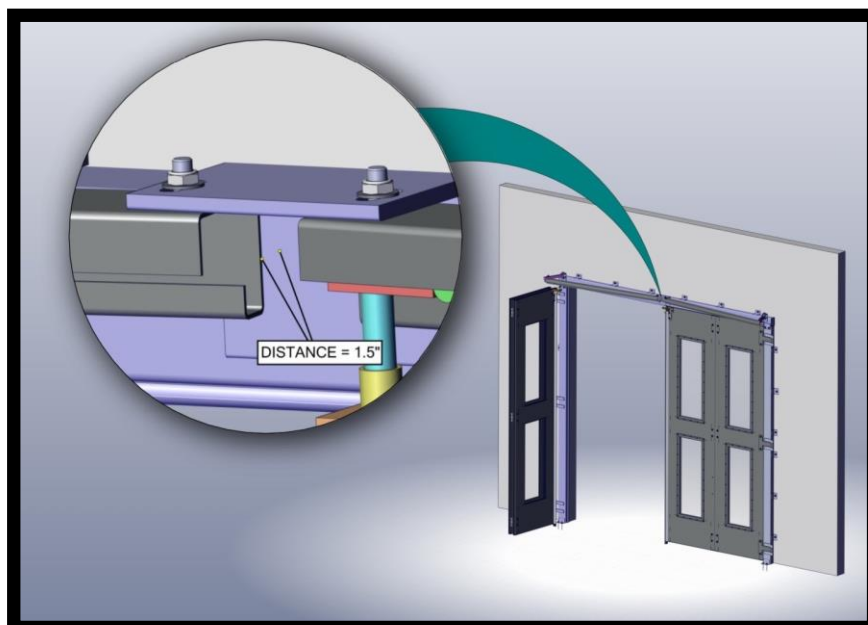

Installation Instructions

Step 8: Panel Adjustment

8.1 End Track Adjustment

- Place jamb panel at 85 degrees
- Adjust end of track until fold panel is parallel with jamb panel.
- Tighten hardware to set track position.
- Return door to closed position and verify panel alignment.
 - Tighten the center track hanger bolts

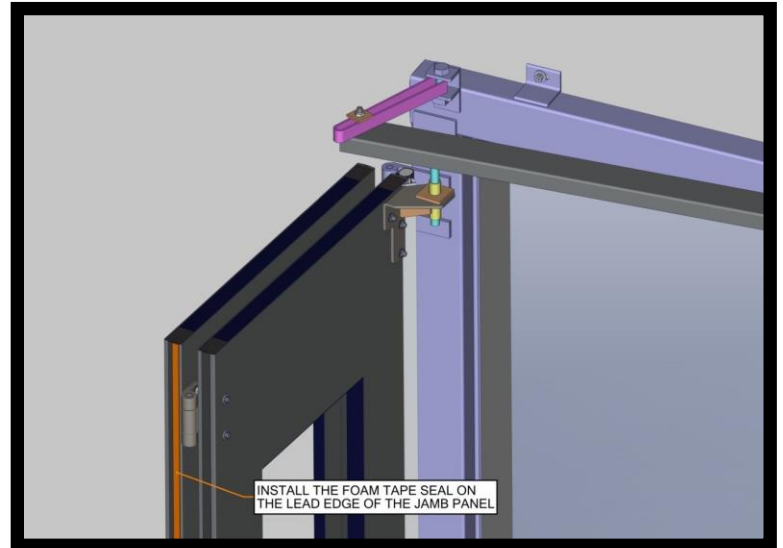

Final adjustments will be made after operator has power

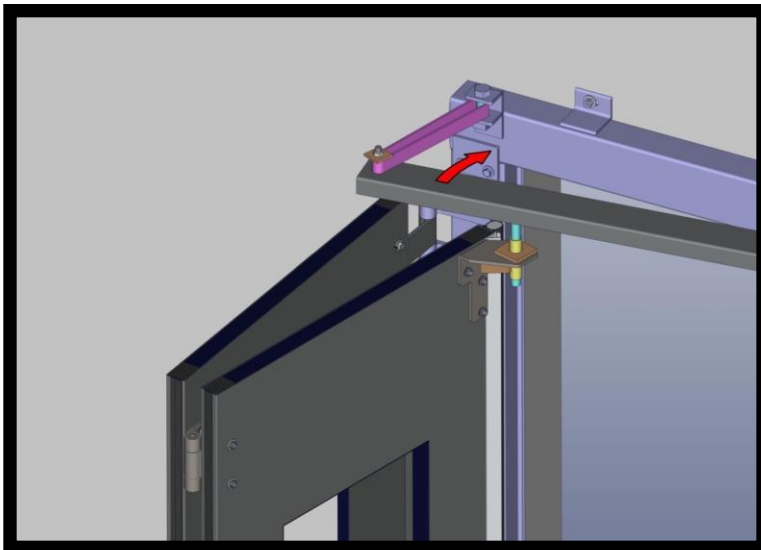

If panels form a “V” from the fold hinge, move the end of the track toward the building.

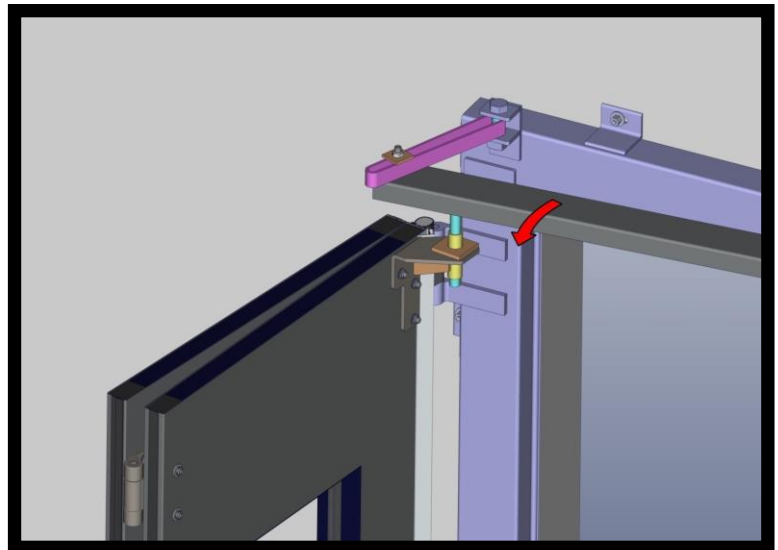

If the panels form an “A” from the fold hinge, move the end of the track away from the building.



Installation Instructions

Step 9: Control Arm Installation

9.1 Installing Control Arm Angle

- Bolt control arm angle to the jamb door panels using supplied hardware.
Align before tightening



Control Arm Bolting Order

1. HHCS .500-13 (See Lengths Below)
2. FW .500 zc
3. Door Panel
4. Control Arm Angle
5. Bonded Washer
6. HNNJ .500-13 zc



2" Door: .500-13 x 3.250" zc
3" Door: .500-13 x 4.250" zc

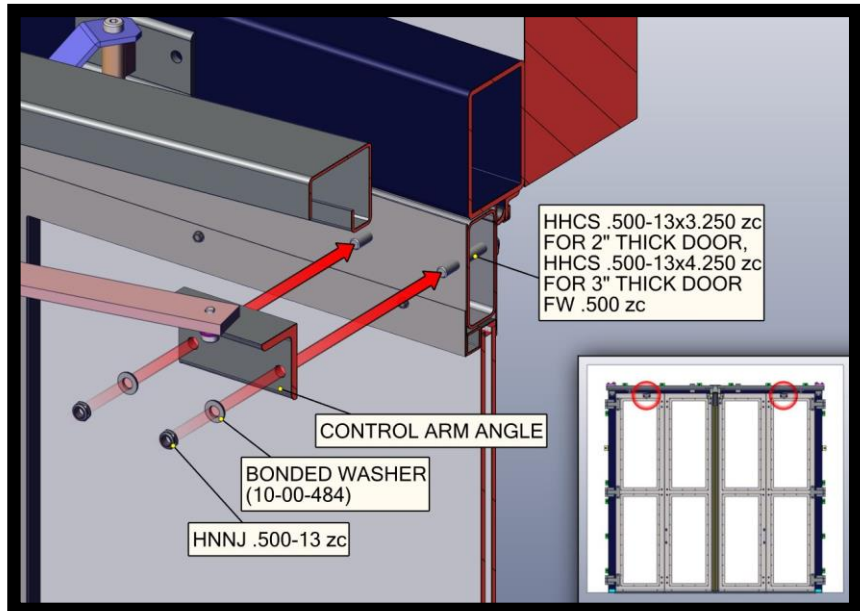

Step 10: Operator Installation

10.1 Identifying Operator

- Reference the **ship loose list** to determine the operator provided (**R1, R2, R3, R3.5/RV2 Series**)

10.2 Mounting Operator

- Lift operator onto **operator support angles** and bolt through **hole referenced** by the Operator Layout Instructions



Operator Bolting Order

1. HHCS .500-13x1.500 zc G5M
2. Operator
3. Operator Support Angle
4. LW .500 zc
5. HN .500-13 zc

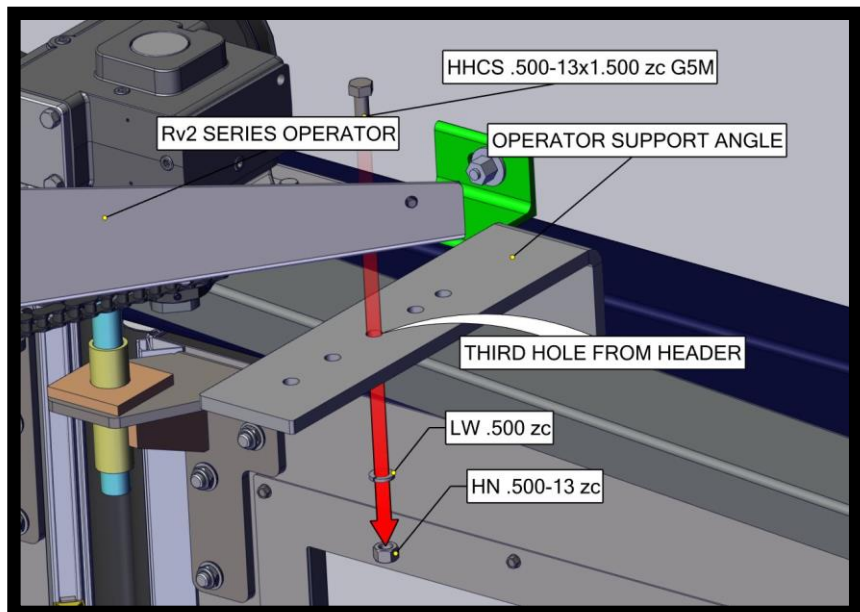

Installation Instructions

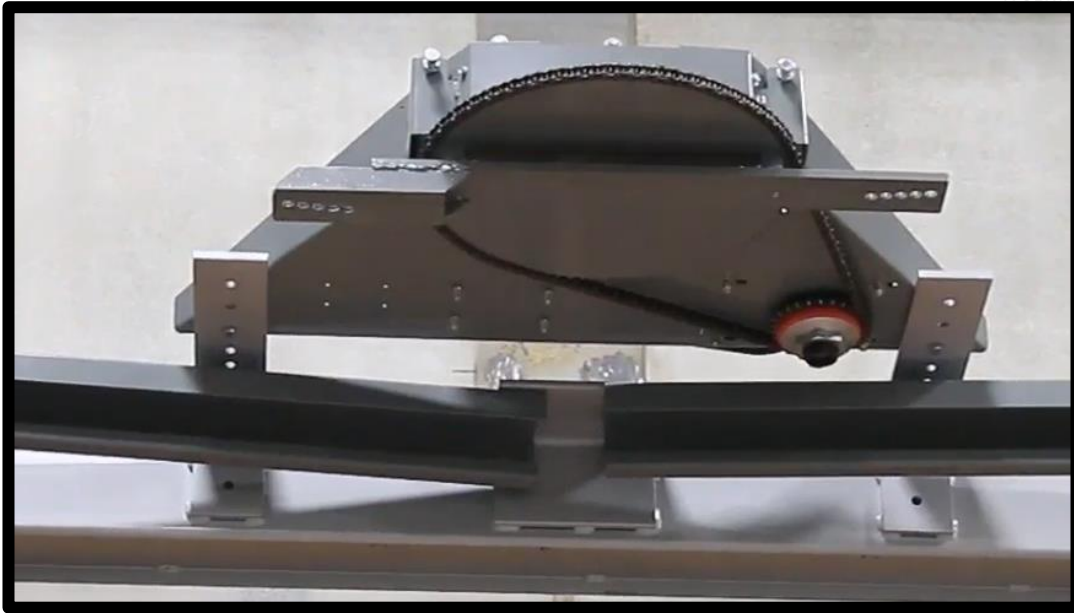

10.3 Operator Mounting

- R1, R2, R3 Operators
 - Level operator at the sprocket
 - Secure operator to operator support brackets
- R3.5 Operators
 - Level operator at the sprocket
 - Install using support straps
 - **Support Straps are shipped flat and must be field formed**
 - **Straps may attach to steel or concrete as required. Reference Operator Layout Section A-A**

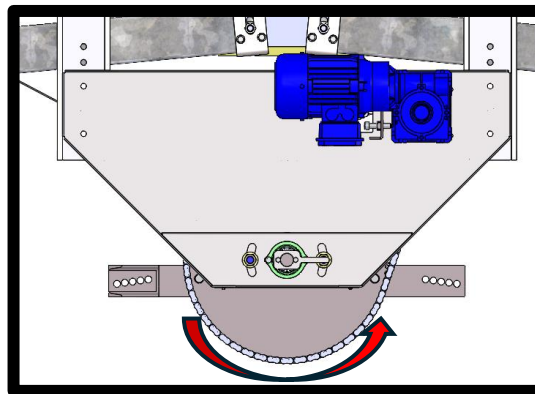

10.5 Wiring and Rotation Check

- Wire the operator per the schematic and electrical riser



TEST OPERATOR ROTATION IN HAND MODE BEFORE INSTALLING CONNECTING RODS

- For Single Operators, sprocket must rotate **clockwise (viewed from below)** while opening
- If operator is rotating incorrectly, **swap leads T1 and T2** in control panel

Installation Instructions

Step 11: Connecting Rods Installation

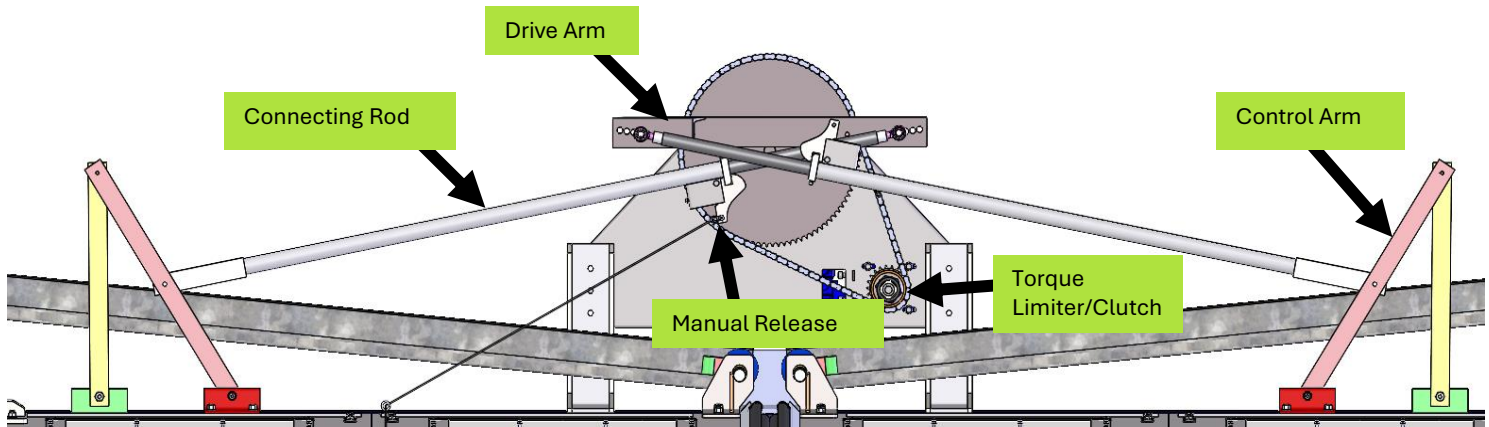

11.1 Connecting Rods Installs

- **Manually** close door panels.
- Loosen set collar and verify release latch operates freely.
- Mount connecting rods per operator layout drawing using hardware kit provided
- Attach the connecting rod to the **hole specified in the drawing**, using the center of the operator **drive arm** as the reference point
- Attach opposite end to top side of control arm as shown
- Adjust rod length with doors fully closed, then tighten 3/8" square set screw. **DO NOT OVERTIGHTEN SCREW! THIS WILL DAMAGE THE THREADS AND MAKE IT DIFFICULT TO DO ADJUSTMENTS**
 - Note: Close position is adjusted by moving set collar.

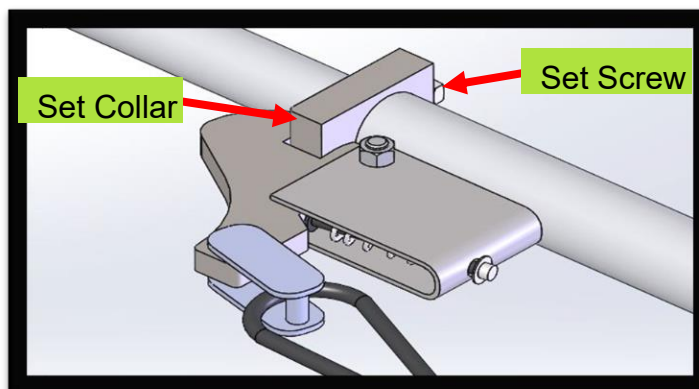

DRIVE ARM AND PROX SWITCHES ARE SET FROM THE FACTORY. DO NOT ADJUST PROX SENSOR POSITIONS UNLESS INSTRUCTED BY DOOR ENGINEERING.



CONNECTING ROD ADJUSTMENTS MUST ONLY BE MADE WHEN THE DOORS ARE IN THE CLOSED POSITION.

Installation Instructions

Step 12: Weathering Installation

12.1 Install Header and Jamb Seal

- Clean weathering angle, header, and jamb surfaces where seals will adhere
- Install the weather strips on **exterior side of door** (squeeze entire length of the edge for even force)

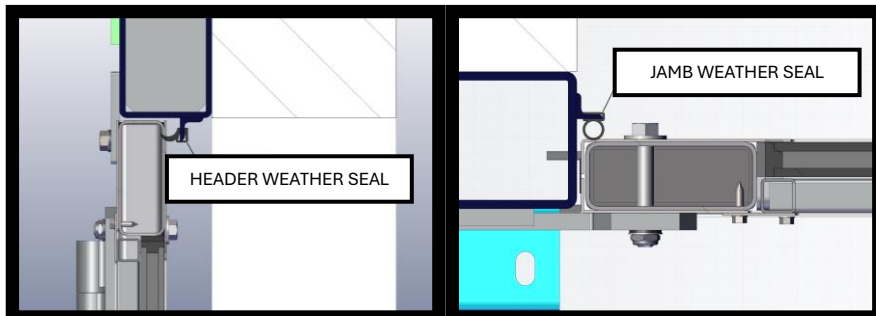

12.2 Install Floor Sweeps (interior/exterior)

- Close door
- Establish a straight reference line across the opening using a laser
- Install seal assemblies using **double sided tape** and **(2) Tek screws per retainer**.
- Test door operation and trim seal edges as required
- Ensure the Sweeps are **overlapping 1/4" from the floor**
- Repeat **12.2** for the opposite side of the door.

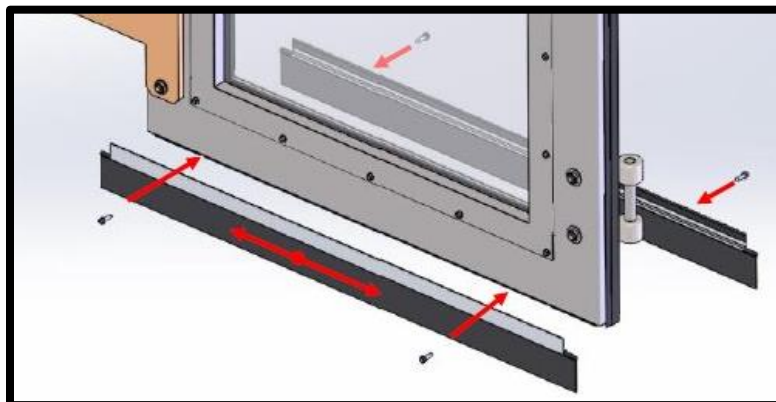

12.3 Center Bulb Seal

- Close door
- Trim center bulb so that the rubber flush with floor in the closed position (just making contact).



Step 13: Pull Handle Installation

13.1 Pull Handle Install

- Install pull handle on lead edge panels (screws are preinstalled in panel)



Bolting Order Handle

1. Panel
2. Pull Handle
3. SHCS .3125-18x 1.250 zc

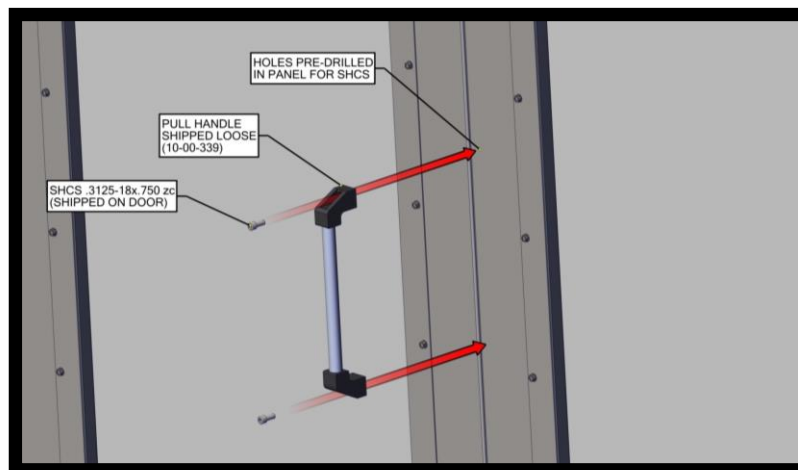

Installation Instructions

Step 14: Window Installation

14.1 Frame Preparation

- Remove the screws securing window frame pieces to the door
- **Carefully** remove the window frames from the door
- If 4 Piece Frames are installed, **Do not remove connecting shims**
- Clean all surfaces where butyl and foam tape will be applied using glass cleaner

14.2 Butyl Tape Installation

- Apply butyl tape to the interior facing side of the door sheeting, 1/4" from edge
- Ensure tape overlaps and fully seals all corners

14.3 Setting Blocks

- Place **neoprene setting blocks (2 per side)** at the **bottom corners** of the window opening

14.4 Install Glass

- Set glass into the window opening on top of setting blocks
- Trim blocks if required

14.5 Foam Glazing Tape

- Wipe interior side of window frame clean
- Apply **foam glazing tape to interior side of window frame**
- Remove tape backing before setting
- Spray glass cleaner to allow final adjustment

14.6 4 Piece Window Frame Alignment

- Position frame against the glass install **center Tek screw first** to allow the frames to move
- Loosen the screws to adjust the frames, once positioned, remove shims
- Install **corner Tek screws** and align frame till **square and flush**
- Install remaining Tek screws

14.7 Final Sealing

- Caulk exterior seams **after glass install**



SKIP STEP 14 IF GLASS WAS PRE-INSTALLED

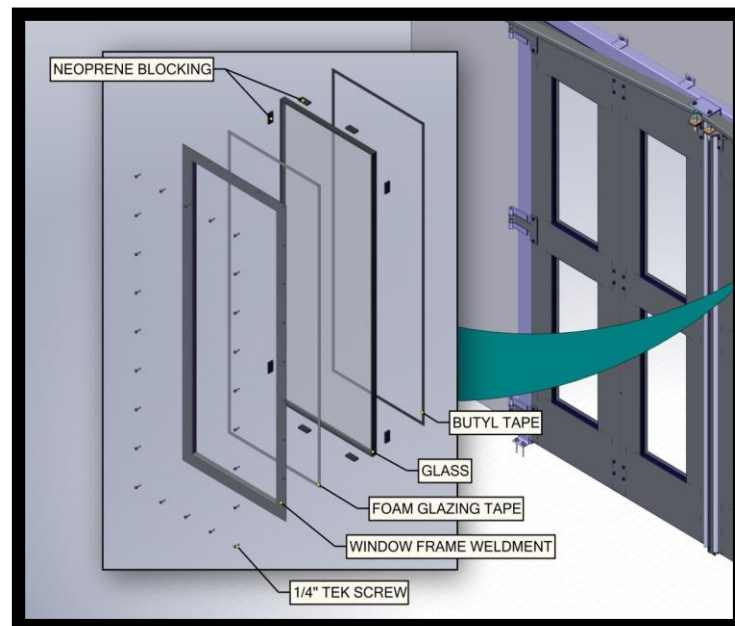
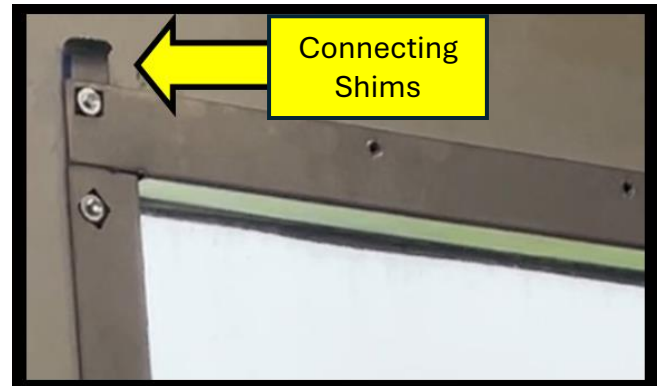

4 Piece Frames follow All Steps
1 Piece Frames follow 14.4, 14.5, and 14.7

Installation Instructions

Step 15: Manual Operated Doors

15.1 Preparation

- Begin with door closed

15.2 First Swivel Eye

- Fasten first swivel eye to the top right or left corner of fold panel
- Position **Swivel Eye #1** with a 1" offset from the top of the panel and a 1" offset from the left side of the fold panel

15.3 Rope Attachment

- Thread end of rope up through **Swivel Eye #1** and form a knot. Attach Knot to connecting rod disconnect with provided chain master link
- Fasten **Swivel Eye #2**

15.4 Route Rope and Handle Install

- Feed opposite end of rope through second swivel eye. Tie tail end of rope to pull handle about 16-24" from **Swivel Eye #2**
- Ring Must be roughly 12" from **top of pull handle**

15.5 Test the manual operation

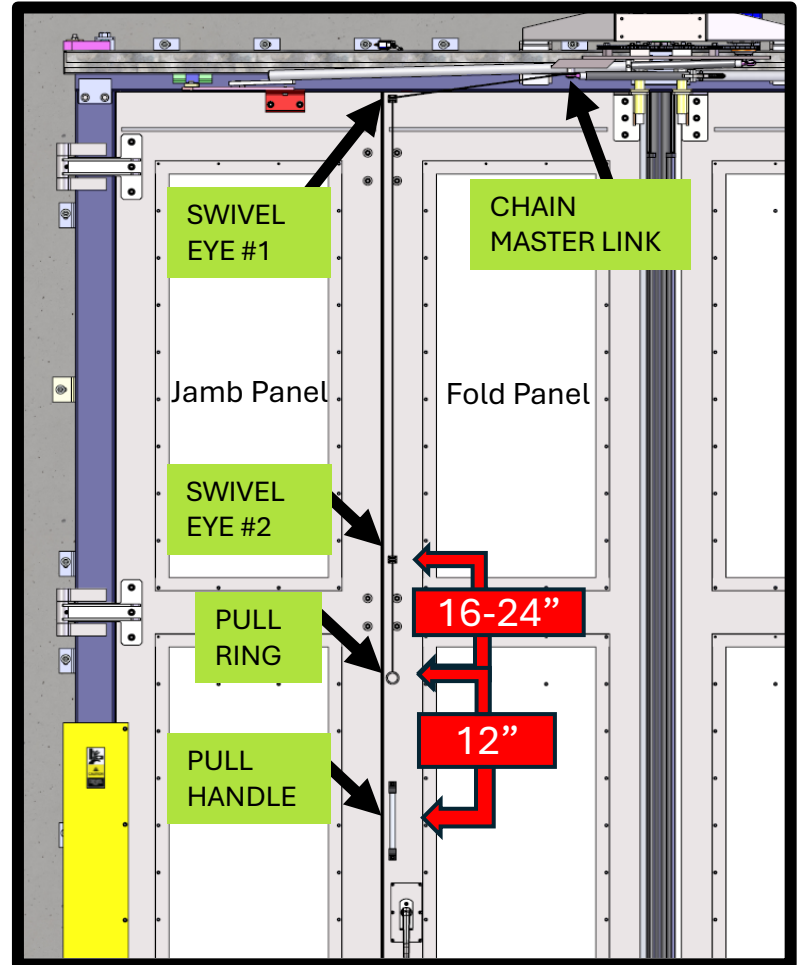

MAKE SURE DOOR PATH IS CLEAR BEFORE PERFORMING TEST

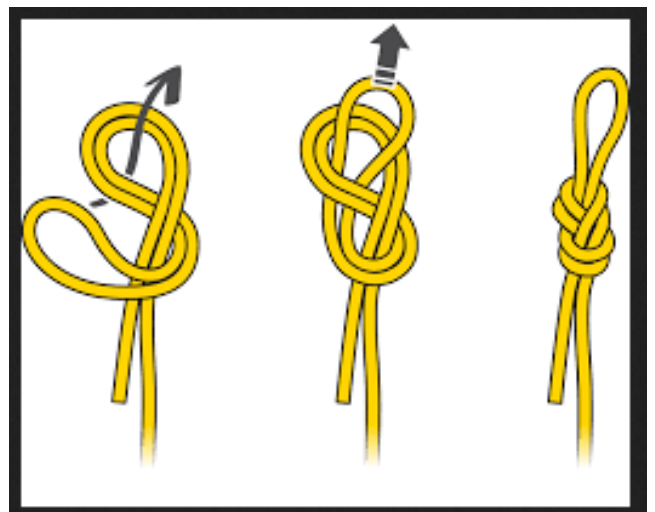
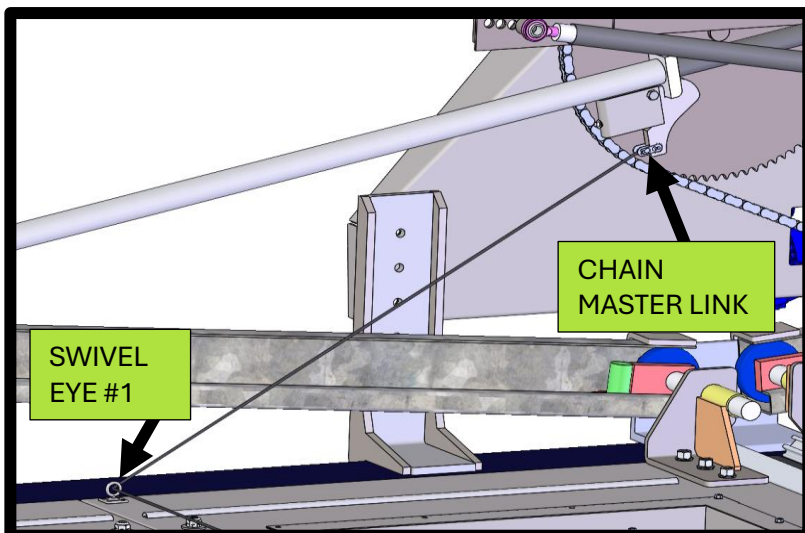

Installation Instructions

Step 16: Hinge Guard Installation

16.1 Position Hinge Guard

- Position Guard 1/2" - 1" from bottom most hinge
- Ensure a **2" panel overlap** to fully cover the hinge gap

16.2 Mount Hinge Guard

- Using the **Hinge Guard Kit**, mount the hinge guard to the **door panel** using the provided fasteners

16.3 Verify Guard Operation

- Open and close the door manually
- Verify the hinge guard:
 - Does **not obstruct door movement**
 - Fully covers the **gap between door panel and frame**

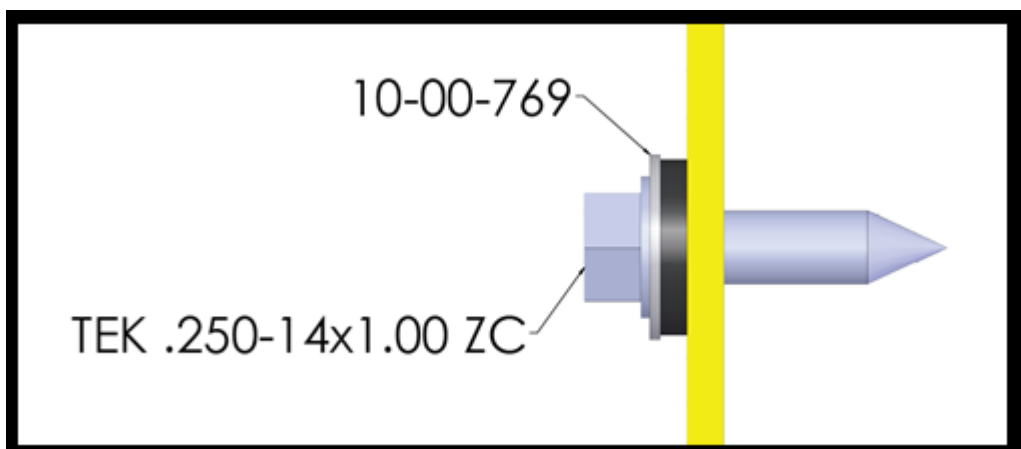
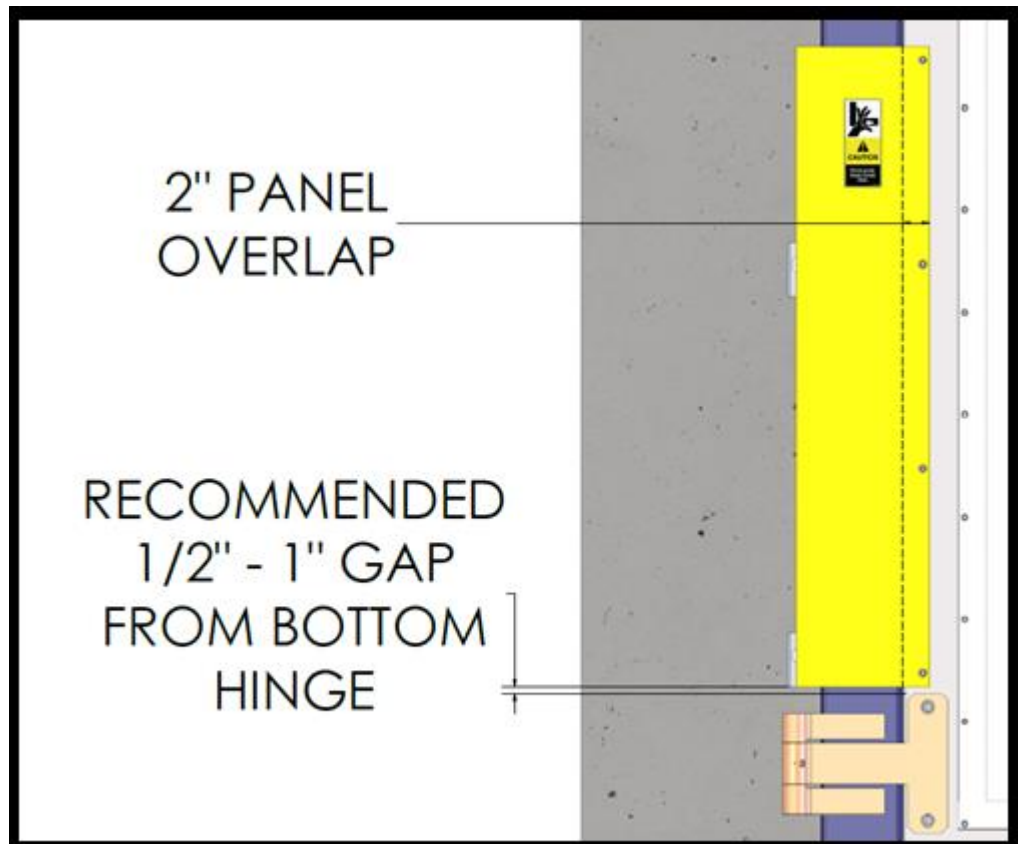

Installation Instructions

Step 17: Safety Labels Installation

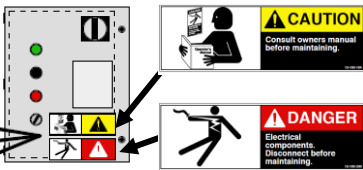
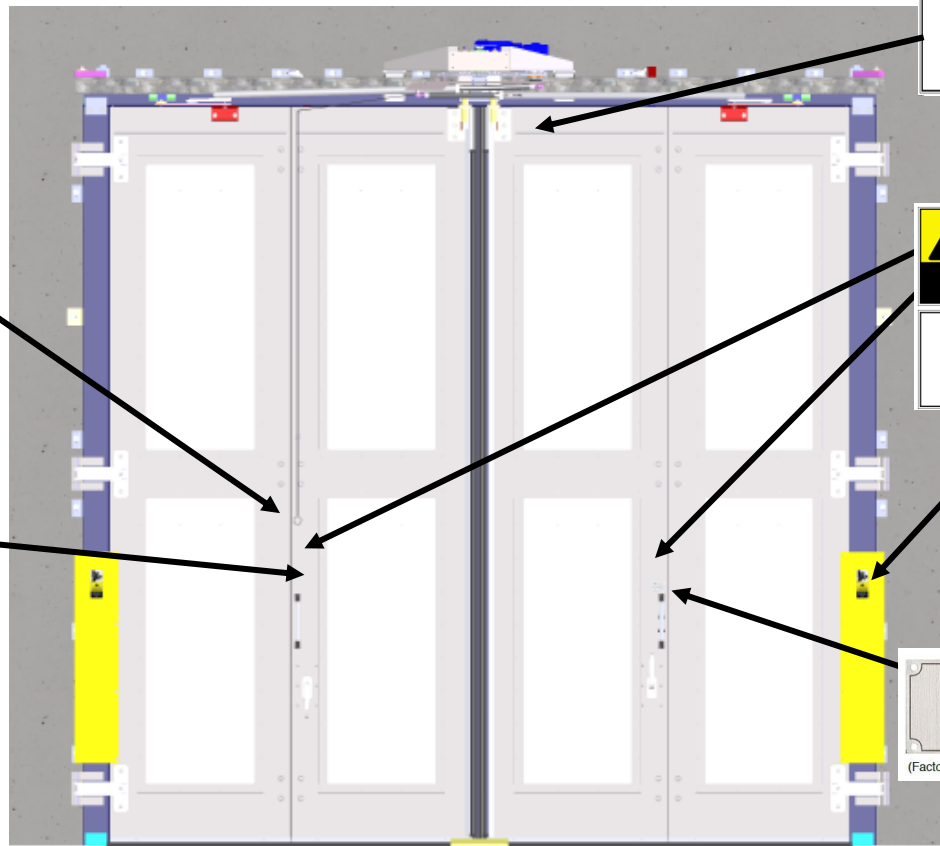
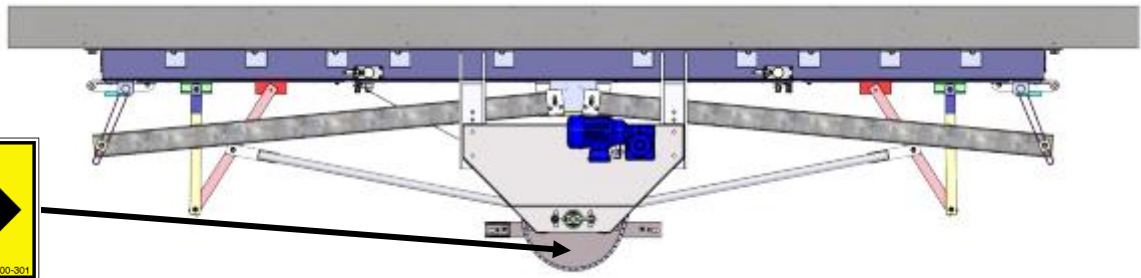

(Factory Installed, Remove plastic cover after finish paint)

17.1 Install Safety Labels

- Locate the safety labels provided in **the shipping crate**
- Reference the **installation drawing** and install labels in **specified locations only**
 - **DE PART# 15-100-501**
- Ensure all labels are:
 - Properly adhered
 - Clearly visible
 - Not obstructed by hardware or door components



SAFETY LABELS ARE REQUIRED FOR PROPER OPERATION AND CODE COMPLIANCE

Installation Instructions

Step 18: Applying Finishing Touches

18.1 Hardware

- Check to make sure all hardware has been tightened on the FF300 door system.

18.2 Door Appearance

- Clean the door surface thoroughly using a warm water and mild dish soap solution to remove all dirt and debris.

18.3 Applying Touch Up Paint

- Each FF300 door system includes a complete paint touch-up kit containing the following:
 - **10-06-106 Spectracon Epoxy Prime Grey (QAP531)**
 - **10-06-107 Spectracon Epoxy Activator (QAP 532)**
 - **10-06-201 Mid-Gloss Clear Base (RAL Topcoat/ RAL and Color)**
 - **10-06-401 Urethane Hardner GXH 1080**
 - **Preval Spray Kit – Includes (1) jar of topcoat (1) bottle of hardener.**



18.4 Primer

- Mix Primer (10-06-106) and Activator (10-06-107) to 1:1 Ratio.
- Mask off the surrounding area and apply only to bare metal.

18.5 Topcoat

- Mix Base (10-06-201) and Hardner (10-06-401 to a 5:1 Ratio (Base:hardner)

Note: Pot life of mixed topcoat is 1-2 hours. Only mix enough for immediate use.

18.6 Prevail Kit

- Paint must be thinned using thinner for proper application from the Prevail sprayer.



DO NOT OVER APPLY PAINT IN LARGE AREAS. ONLY APPLY PAINT TO SCRATCHES AND DINGS THEMSELVES. AVOIDE RUNS!

Additional Hurricane Installation Instructions

Step 1: Cremone Keepers for FF701 Doors



If Installing a non-FF701 door, **SKIP THIS STEP**

1.1 Preparation

- Perform this installation after the door has been fully installed and adjusted
- Begin with the door in the closed position

1.2 Locate Cremone Keeper

- Extend the cremone rod until it contacts the floor
- Mark the outside diameter of the cremone to establish the drill center using chalk or marker

1.3 Install Centering Washer

- Pre-drill pilot hole
- Secure centering washer in place using Tapcon

1.4 Core Drill Floor

- Core drill floor using 1 1/2" diameter core bit
- Drill a hole to a depth of 3 1/8"

1.5 Install Cremone Keeper

- Insert cremone keeper into hole so the top is flush with the floor
- Remaining hole to be filled with epoxy

1.6 Final Inspection

- Ensure cremone keeper and adhesive are flush with floor

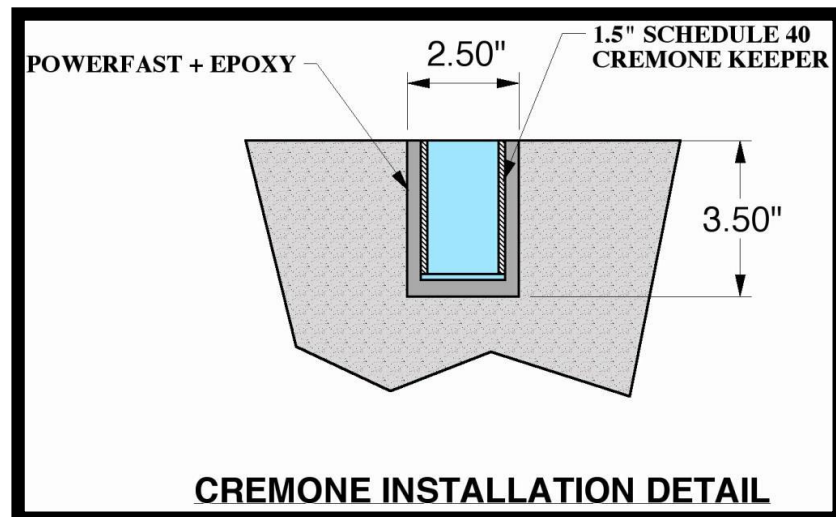
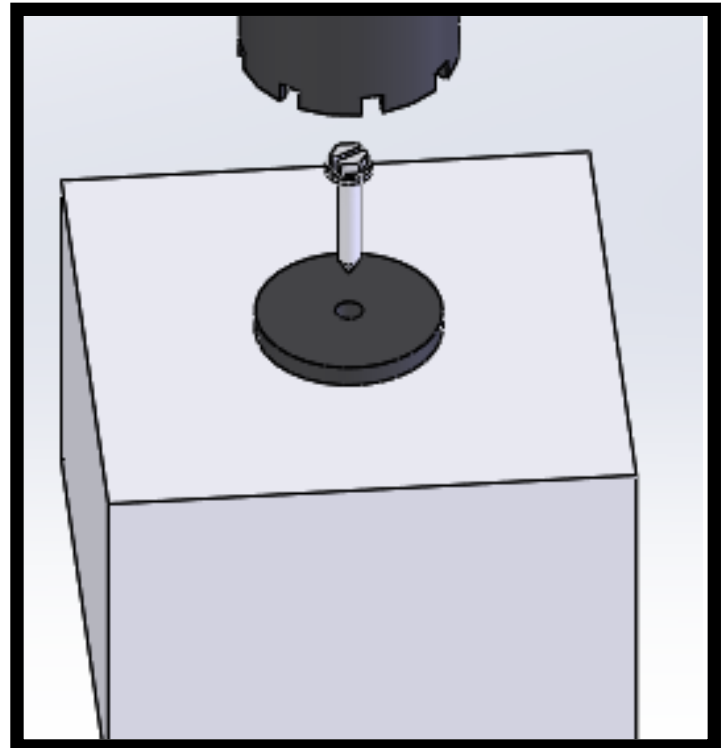

ENSURE CREMONE LOCKS ARE NOT IN THE LOCKED POSITION WHEN OPERATING DOOR. DAMAGE TO DOOR MAY OCCUR!!

Additional Hurricane Installation Instructions

Step 2: Hurricane Astragal Installation



If Installing a non-FF701 door, **SKIP THIS STEP**

2.1 Hurricane Astragal

- Astragal needs to be **1"** from both **top** and **bottom** of the door frame.
- Front face of Astragal is to be **5/16"** from **front face of door panel**.
- This can be installed on either fold panel.
 - Manually open door halfway. Place, mark location and screw in lower half of Astragal. Tighten down 1/4" TEK Screws.
 - Mark location and screw in upper half of astragal. Tighten down 1/4" TEK Screws.



Astragal Bolting Order

1. Lead Panel
2. Center Astragal
3. 1/4" Tek Screw
4. Astragal Weathering

- Trim the **top seal** so it is touching the headers without flexing
- Trim the **bottom seal** so it overlaps the floor by 1/4"
- Press on the Astragal Seal.
- Close doors manually and check for clearance between Astragal and door.

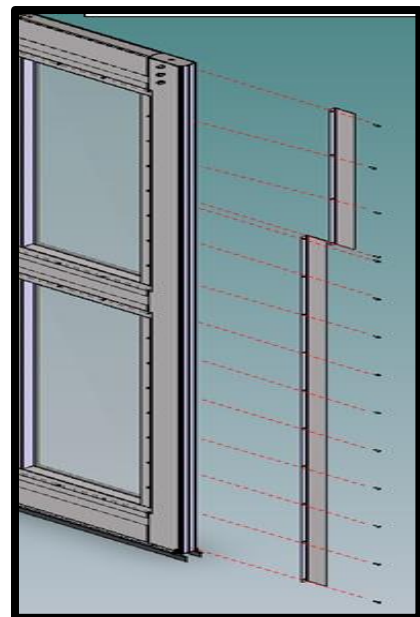
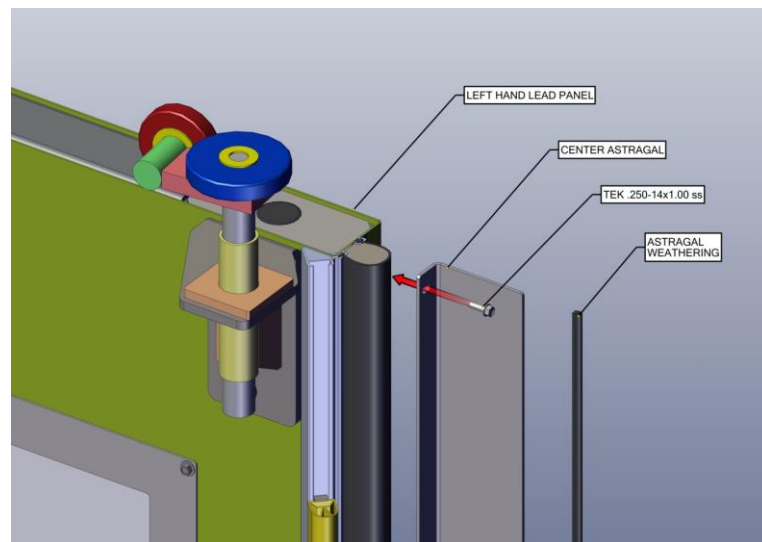
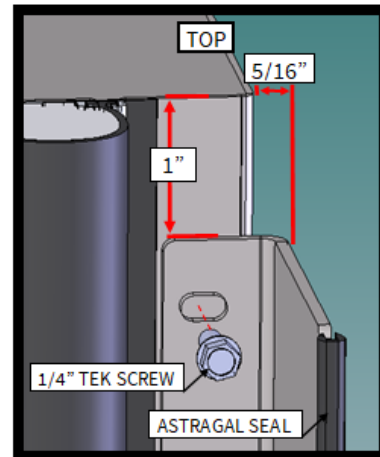

Hurricane Installation

2.2 Track Reinforcement Instructions (FF701)

- When installing the track reinforcement, mount them on top of the track mount
- After final track adjustment is complete, butt the track bracket against the outside of track.
- Install 3/8" thread cutter to lock the bracket to the track and the track mount.



Track Reinforcement Bolting Order

1. Track Reinforcement
2. 3/8" Thread Cutting Screws
3. 5/8" Washer
4. 5/8" Lock Nut

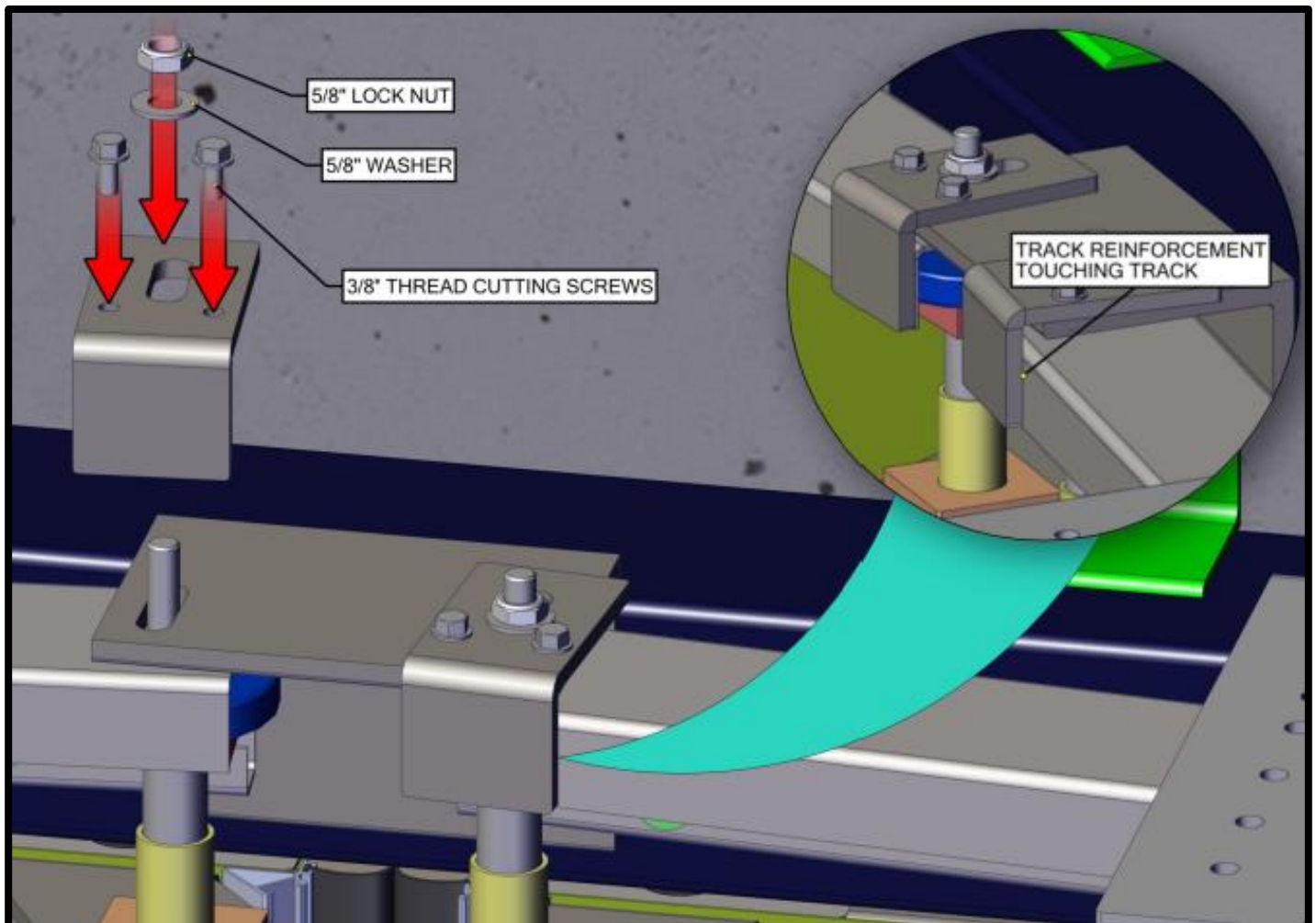

Optional Equipment

Step 1: Floor Guides

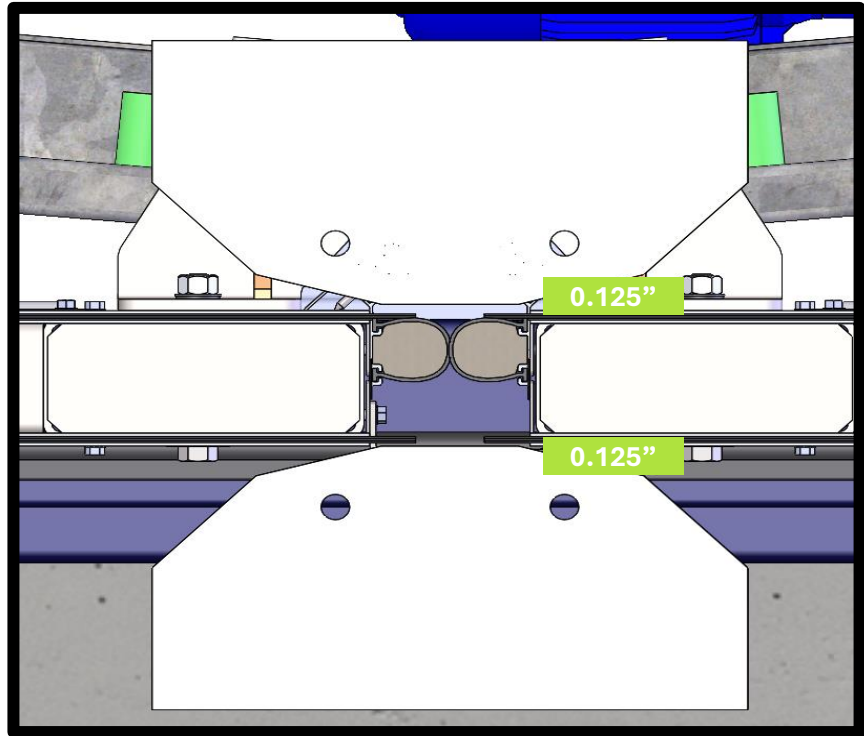

1.1 Preparing Floor Guides

- Verify that doors are aligned properly at the center of the opening. Offset 1/8" between door and guide

1.2 Installing Floor Guides

- Anchor with 1/2-13 x 3 3/4" Wedge

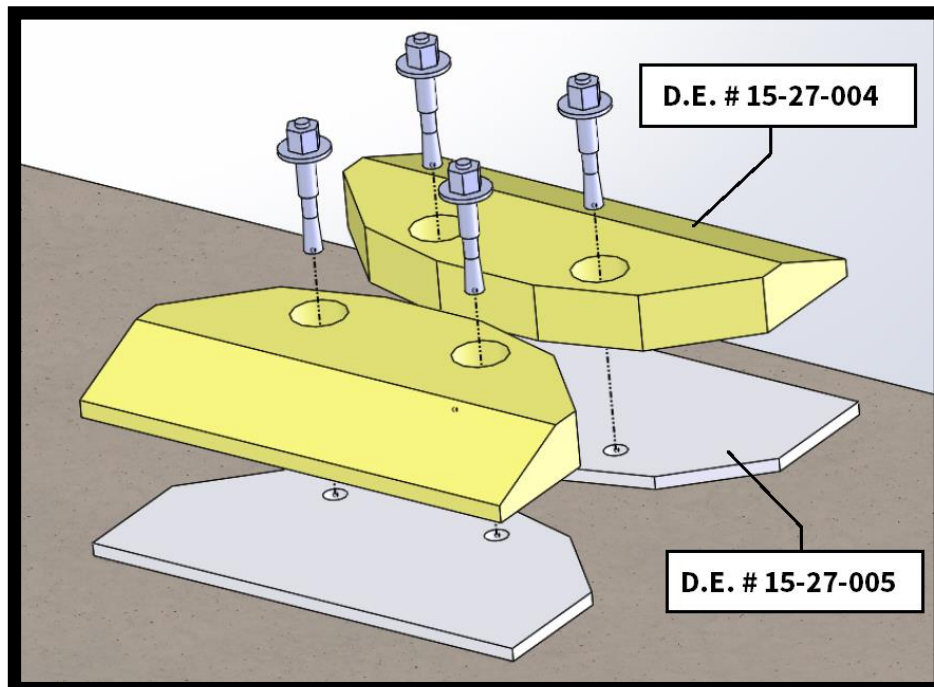

Optional Equipment

Step 2: Throttle Cable Installation

2.1 Drill Wall Penetration

- Drill a 1" diameter hole in the building wall that is 10" above the top of the header tube
- Route the throttle cable from the interior to the exterior, ensuring the lever remains inside the building

2.2 Prepare Cable Hardware

- Thread one 10-32 nut onto the throttle cable toward the end of the threaded section
- Verify that sufficient thread remains for final tightening

2.3 Attaching Cable to Lever

- Insert the cable into the **U-shaped lever connection**

2.4 Securing Cable

- Thread and tighten the **second 10-32 nut** until cable is secure

2.5 Attaching Cable to Lever

- Remove one half of the disconnect cover

2.6 Verifying Cable Fit

- Ensure the cable seats in the cover slot and tighten the nut until **flush with the cover**

2.7 Reinstall Cover

- Reinstall the removed cover half and re-verify cable fit

2.8 Final Tightening

- Fully tighten the second nut on the throttle cable

2.9 Set Cable Slack

- Allow enough interior slack to maintain a **minimum 5" bend radius**

2.10 Clamp Cable

- Secure the loose cable to the wall using the supplied cable clamp

2.11 Mount Lever and Seal Wall Penetration

- Secure the lever to the wall using the supplied **TEK screws**
- Once secured, seal the wall hole with **interior grade caulking**

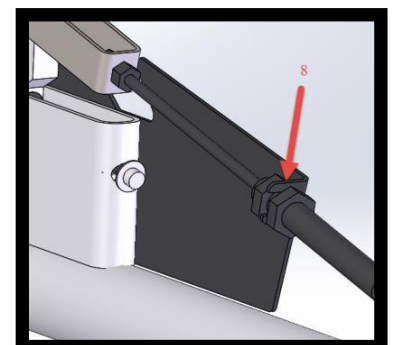
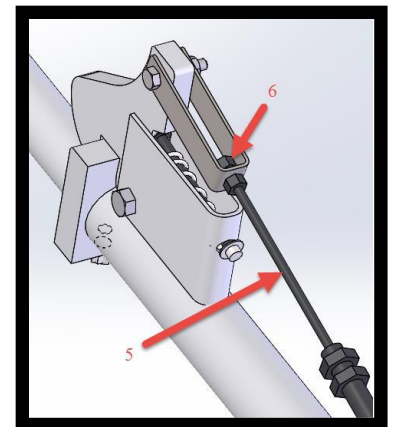
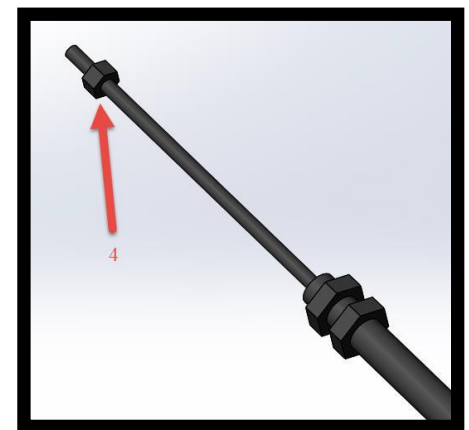
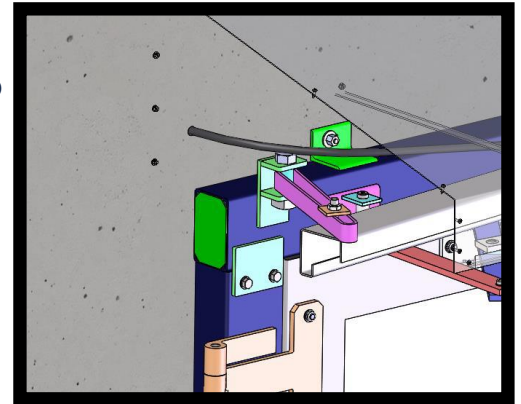

Alternative Operator Installation Instructions

Step 1: Dual Operator Installation

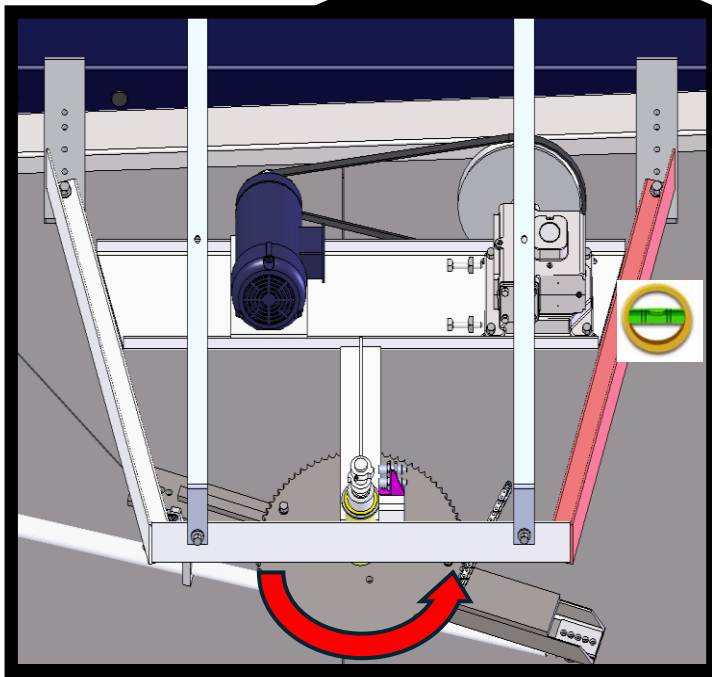
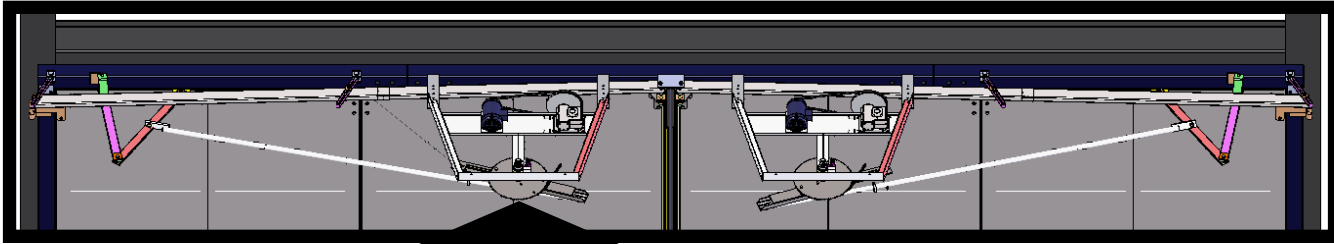

1.1 Mounting Operators

- Lift the operator on top of the operator support angles and bolt through proper hole as referenced by as **built and appendix for the associated operator**

1.2 Leveling and Installing Support Straps

- Level and install the support's straps.
- Support straps are shipped flat and must be formed on the field

1.3 Wiring and Rotation Check

- Reference the schematic and electric riser to wire the operators. **TEST THE OPERATOR ROTATION BY HAND BEFORE INSTALLING CONNECTING RODS**
- For Dual Operators, The Sprocket should rotate clockwise while opening the door
- If operator is rotating incorrectly, switch polarity by switching leads T1 and T2 in control panel

1.4 Connecting Rods Installation

- Manually close door panels.
- Loosen set collar and verify release latch operates freely.
- Mount connecting rods as showing in corresponding operator detail using bolts located in the operator hardware kit
- Attach the connecting rod to the **hole specified in the drawing**, using the center of the operator drive arm as the reference point
- Attach other end to the top side of the control arm as shown in operator layout.
- Secure set collar by tightening the 3/8" square set screw – **do not overtighten.**
 - Note: Close position is adjusted by moving set collar.



DRIVE ARM AND PROX SWITCHES ARE SET FROM THE FACTORY. DO NOT ADJUST PROX SENSOR POSITIONS UNLESS INSTRUCTED BY DOOR ENGINEERING.



CONNECTING ROD ADJUSTMENTS MUST ONLY BE MADE WHEN THE DOORS ARE IN THE CLOSED POSITION.

Alternative Operator Installation Instructions

Step 2: FF300 Exterior Operator Installation

2.1 Bracket Installation

- Locate the **two operator brackets**
- Mount the brackets to the left and right side of **interior wall (Refer to the drawing when mounting)**
- Ensure the brackets are **leveled** before bolting

2.2 Bolting Operators

- Once brackets are fastened, locate the operators and bolt them onto brackets



If Installing a Non-Exterior Door, SKIP THIS STEP

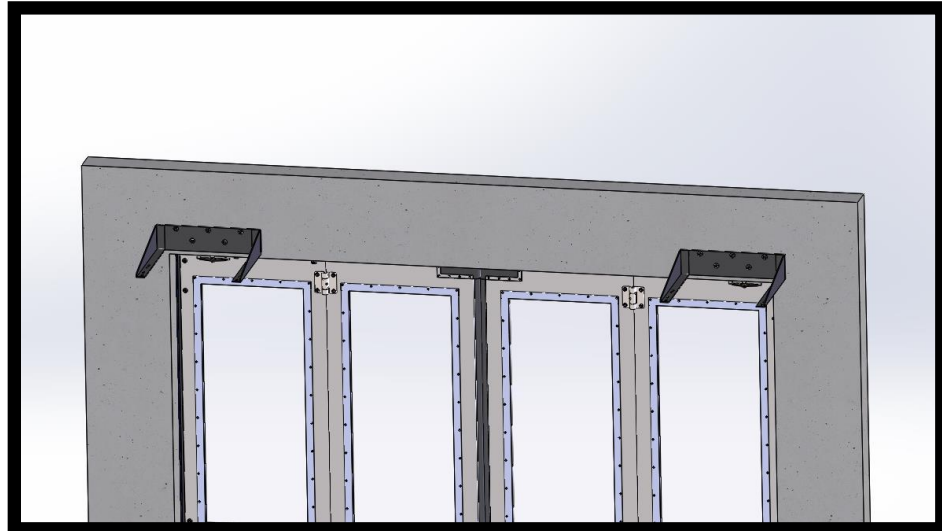

Outer Hardware Bolting Order

1. 3/8" x 1 1/2" HHCS
2. 3/8" FW
3. Operator Base
4. Operator Wall Mounting Bracket
5. 3/8" FW
6. 3/8" LW
7. 1/8" HN



Inner Hardware Bolting Order

1. 1/2" x 1 1/2" HHCS
2. 1/2" FW
3. Operator Base
4. Operator Wall Mounting Bracket
5. 1/2" FW
6. 1/2" LW
7. 1/2" HN

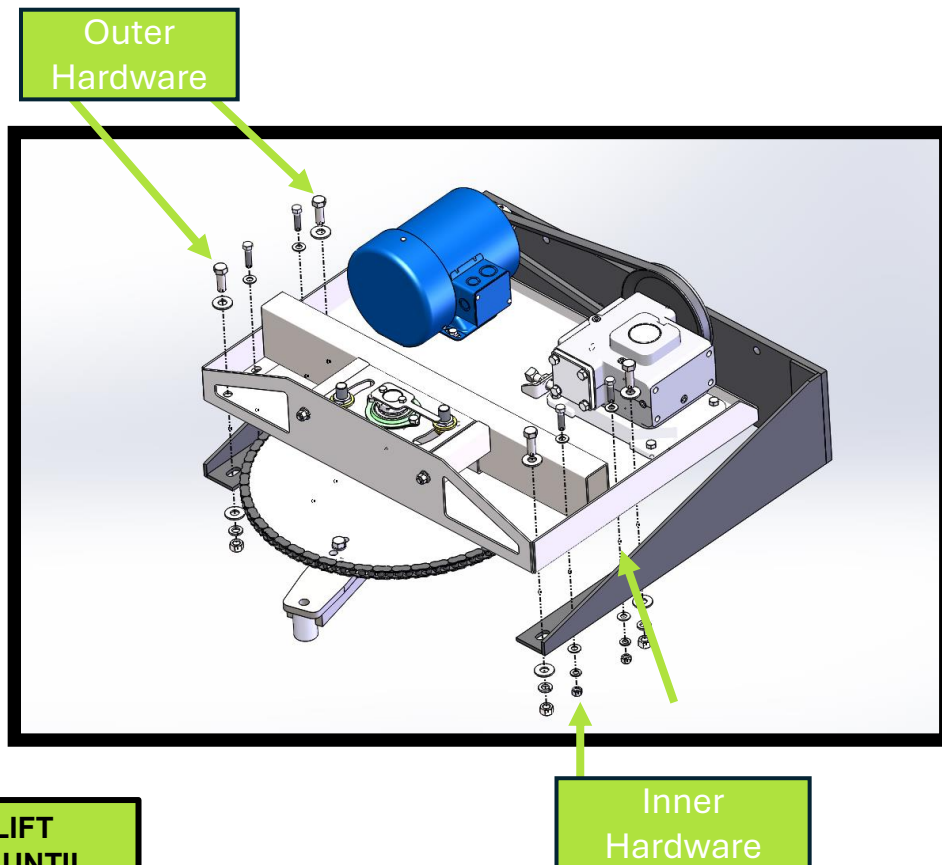

USE A FORKLIFT TO HELP LIFT AND SUPPORT OPERATOR UNTIL IT IS FULLY SECURED

Alternative Operator Installation Instructions

2.3 Orientation Reference

- Operator will arrive as illustrated. Diagrams show left-hand and right-hand, open and closed orientations referenced from the wall. Reference project drawings for correct operator position (Top: Standard Installation, Bottom: Special Use)

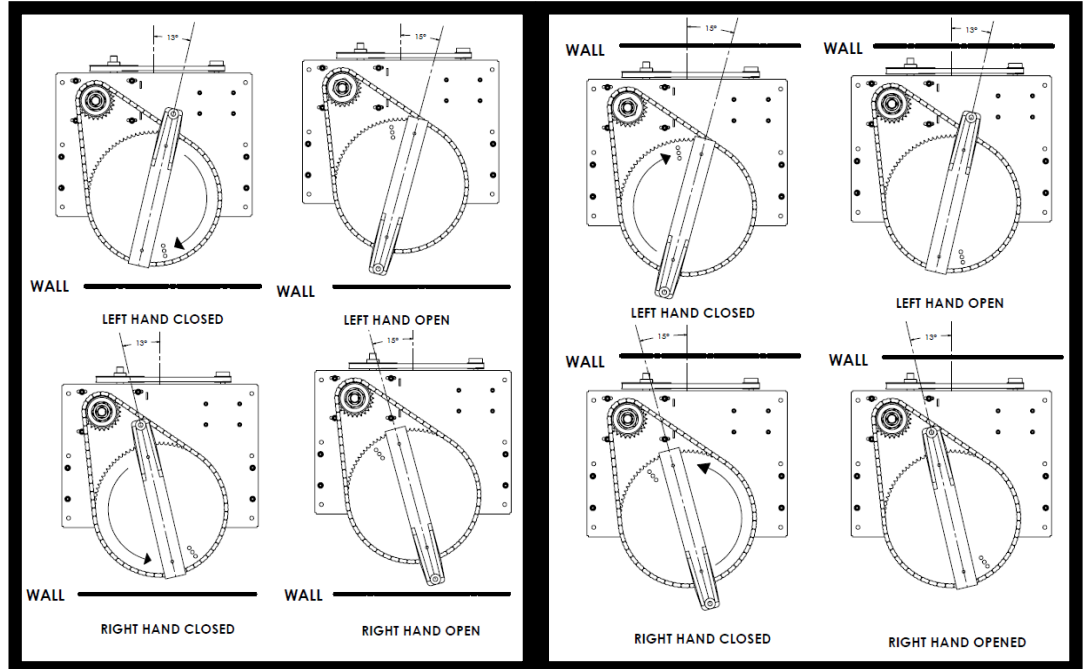

2.4 Wiring and Verification

- Wire the operator per the schematic and as built drawings
- Test operator rotation before installation connecting rods. They must rotate correctly when open button is pressed
- If rotation is incorrect, reverse polarity by switching leads in the control panel

2.5 XT Connecting Rods

- With door and operator in closed position, install connecting rods (page 45)
- Tighten set screws on the connecting rods
- Test door operation after installation

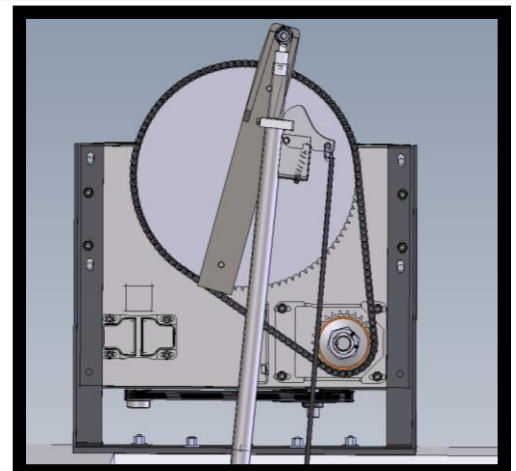
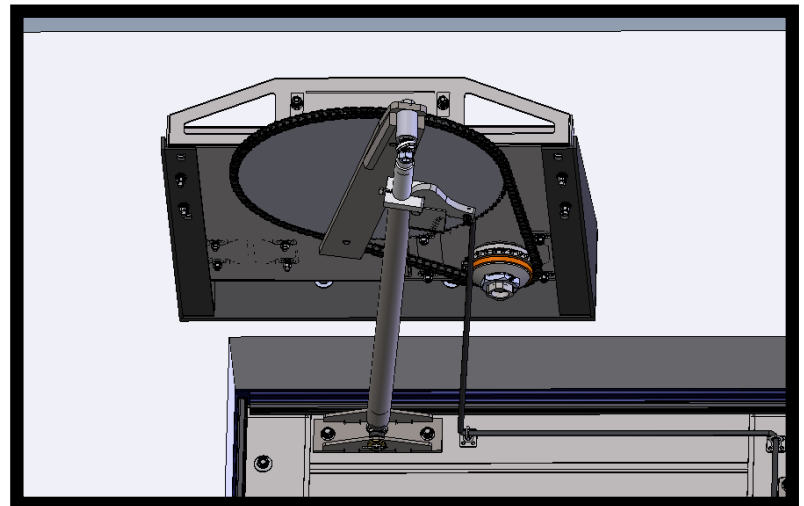

DRIVE ARM AND PROX SWITCHES ARE SET FROM THE FACTORY. DO NOT ADJUST PROX SENSOR POSITIONS UNLESS INSTRUCTED BY DOOR ENGINEERING.

Alternative Operator Installation Instructions

Step 3: Side Mounted Hydraulic Operator Installation



If Installing a Non-Side Mounted Hydraulic Door, **SKIP THIS STEP**

3.1 SMH Operator Mounting

- Mount the brackets to both sides of the building and opening (**Reference Drawings When Mounting**)
- Bolt the operator enclosure to the operator support brackets
- Attach the drive arm and connecting rod
 - Operator may need to be disconnected to rotate drive arm into position
- Attach to jamb or header tubes if applicable

3.2 Operator Linkage Adjustment

- Operator uses **proximity-type electric limit switches**.
- Operator is factory set to rotate **180° between open and closed positions**.
- Limit switches are in **slots on the operator base** and secured with mounting nuts.

3.3 Linkage Requirements

- Use a laser straight edge to verify the **straightness** the link is to operator arm
- Maintain **5° minimum clearance** between the **drive arm** and **operator enclosure**
- Ensure **connecting rod**, **drive arm**, and **jamb nut** are properly tightened

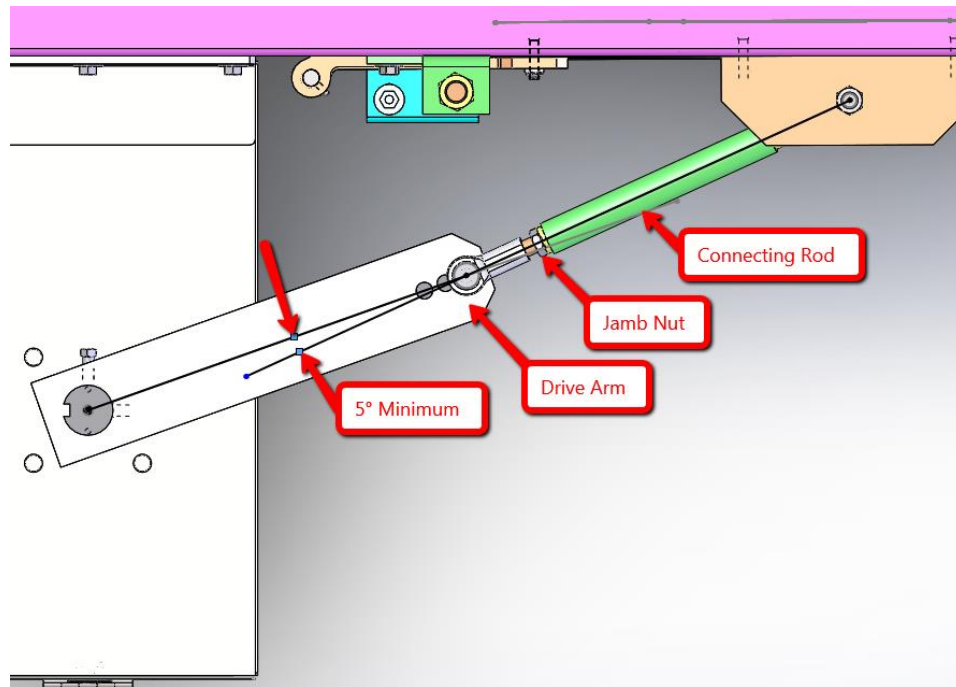
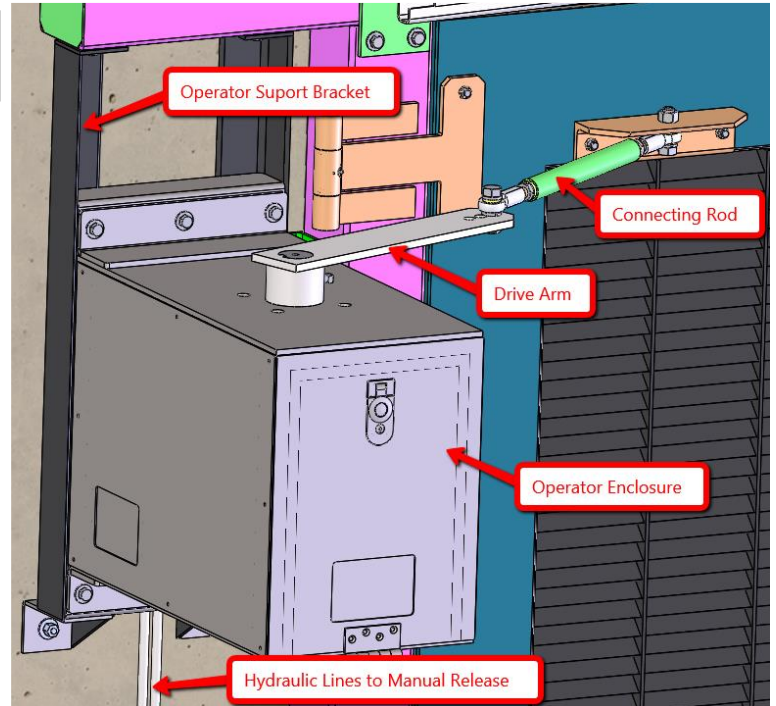

All operator and linkage adjustments must be made with doors in **CLOSED** position

DRIVE ARM MUST BE TILTED STICKING ON THE OUTSIDE TO PREVENT DAMAGE WHEN OPERATING

Alternative Operator Installation Instructions

HEX NUT (HN .750-10 zc)
MOUNTING ANGLE (PN: 1-69-041)
LOCK WASHER (LW .750 zc)
CONNECTING ROD (PN: 1-65-041)
LOCK WASHER (LW .750 zc)
HEX BOLT (HHCS .750-10x2.500 zc)

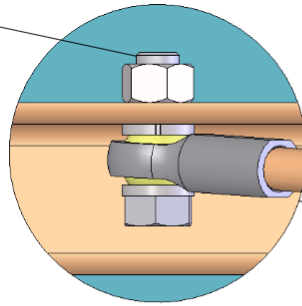

TYPICAL SIDE MOUNT HYDRAULIC OPERATOR
FASTENER ORDER, RIGHT HAND SHOWN

HEX BOLT (HHCS .750-10x2.500 zc)
LOCK WASHER (LW .750 zc)
CONNECTING ROD (PN: 1-65-041)
LOCK WASHER (LW .750 zc)
CONTROL ARM (PN: 1-54-071)
HEX NUT (HN .750-10 zc)

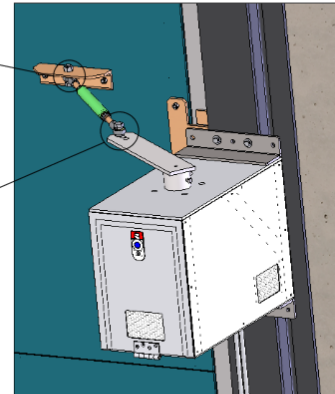
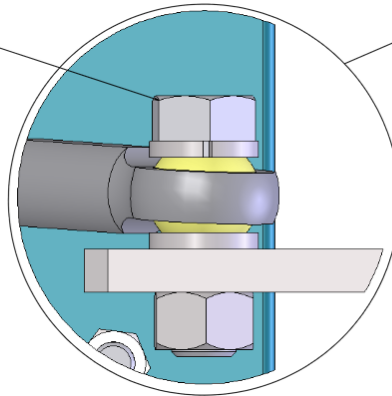

3.4 Linking Rod Alignment and Manual Disconnect

- Rotate the **hydraulic disconnect handle** to disconnect the door for **manual operation**.
- Loosen the **jamb nuts** on the connecting rod.
- With the door **closed**, align the **drive arm** and **connecting rod** to **approximately 5° minimum**. Use a straight-line edge to confirm straightness
 - The connecting rod may need to be **extended** to achieve alignment.
- Tighten the **jamb nuts** on the connecting rod. Install the **connecting rods** per the **operator layout**.

3.5 Limit Switch Adjustment

- Proximity limit switches **do not require adjustment unless operator linkage has been changed**.
- Switches are factory set with **4 mm (1/8 in) gap** from sensor face to target.
- **All adjustments must be made with doors CLOSED.**
- **Adjustment Steps**
 - Disconnect power and open operator enclosure.
 - Adjust **CLOSED limit** on valve position sensor.
 - Open door **manually**.
 - Adjust **OPEN limit** on valve position sensor.
 - Close door and restore power

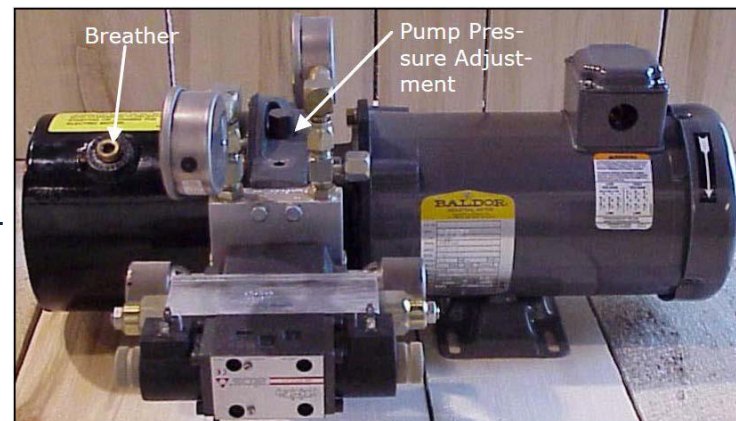

Overadjustment can damage connecting rods and operator components

Alternative Operator Installation Instructions

3.6 Hydraulic Operator Adjustment

- Hydraulic system is **filled and bled prior to shipment**.
- Pressure Relief Valve is preset to **600 psi**.
 - Clockwise adjustment **increases pressure**.
- Maximum pump pressure is 3,000 psi**.
- Flow control module adjusts **door speed** based on door size.

3.7 Counterbalance Valve Adjustment

- Counterbalance valve controls **deceleration and acceleration**.
- Proper adjustment is **required for smooth stopping and starting**.
- Valve adjustment helps prevent damage during **mid-travel stops or safety edge reversal**.
- Adjustment
 - Rotate valve to adjust cushioning
 - Adjust until door decelerates smoothly and accelerates without coasting

3.8 Manual Operation

- If required, these doors can be opened and closed by manpower
- Doors should not be moved faster than is possible under electrical power

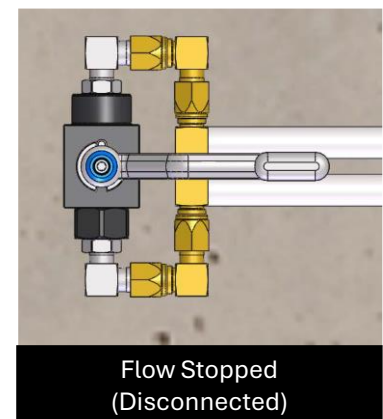
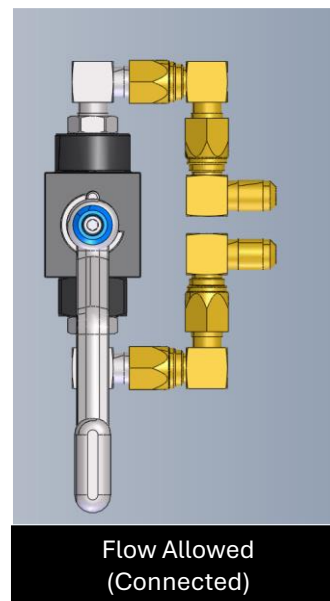
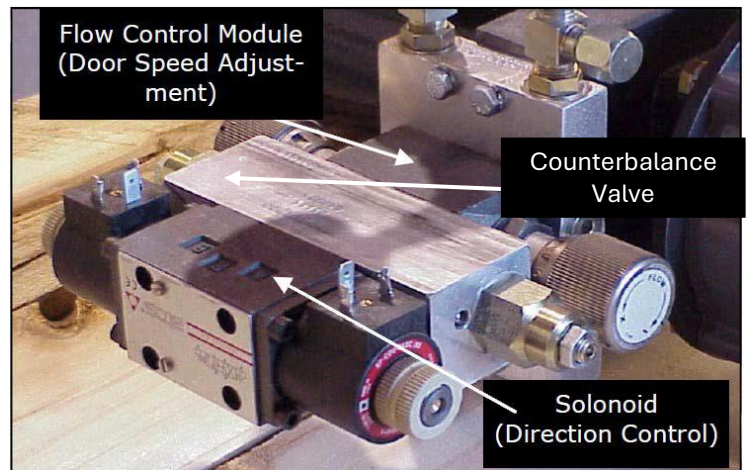

Appendix: R1 Operator Layout

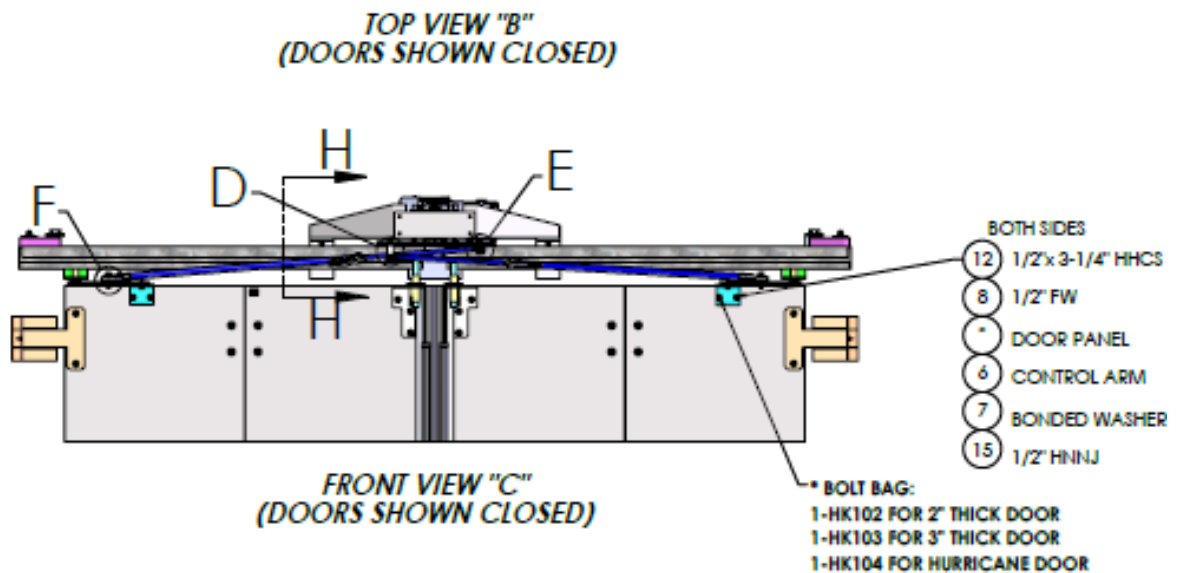
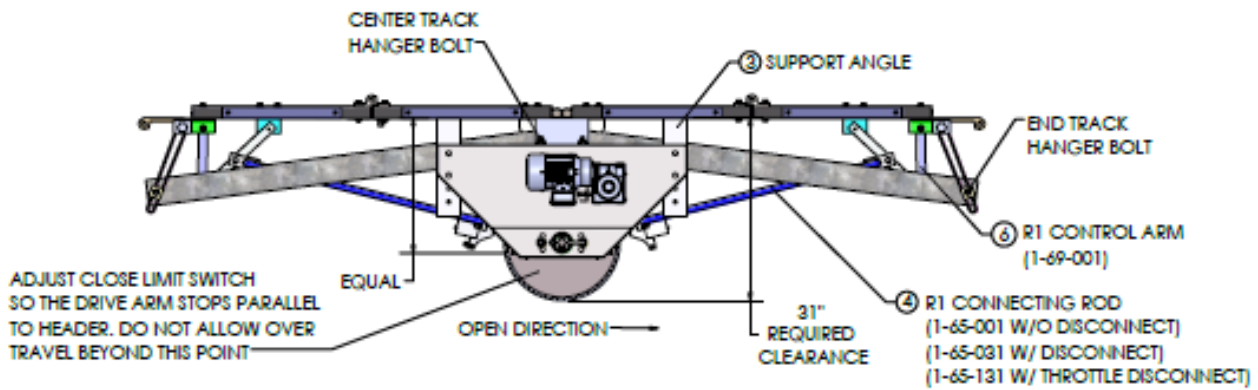
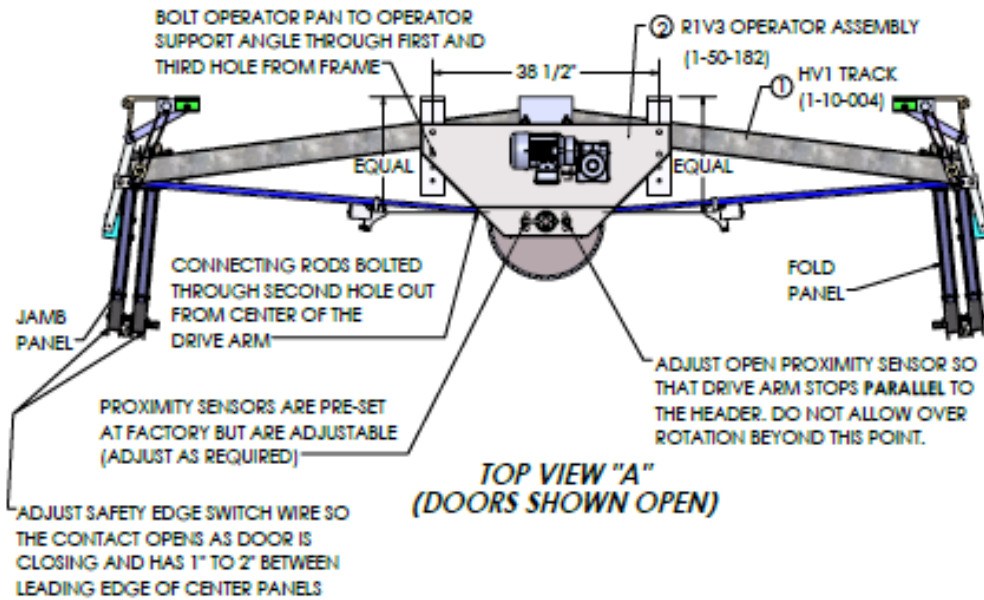

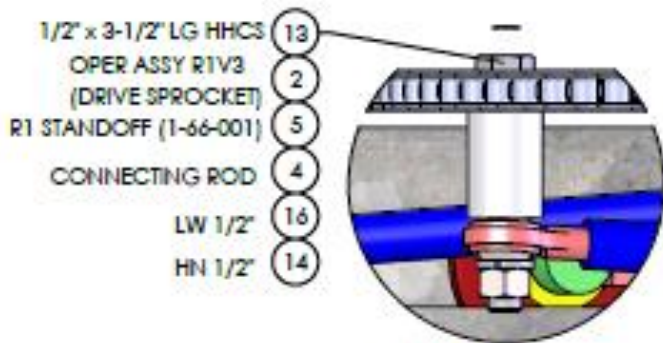

DETAIL D
SCALE 1 : 3

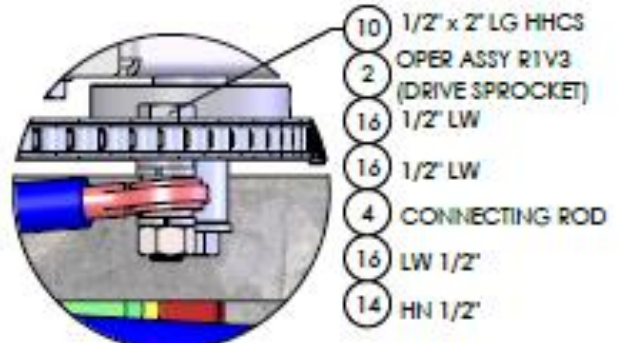

DETAIL E
SCALE 1 : 3

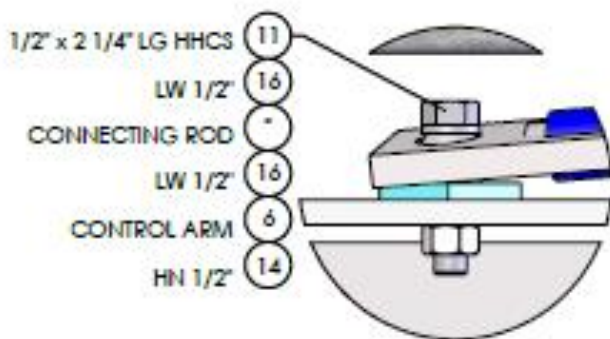

DETAIL F
SCALE 1 : 3

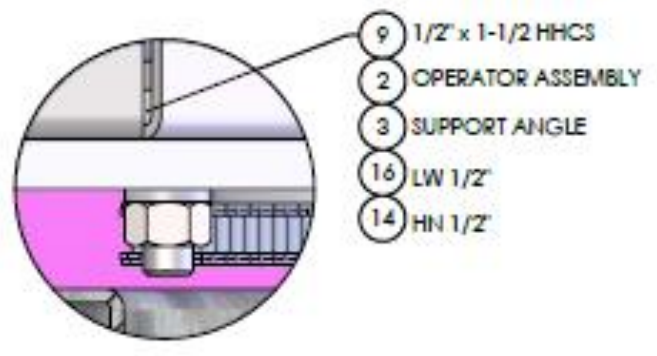

DETAIL G
SCALE 1 : 2

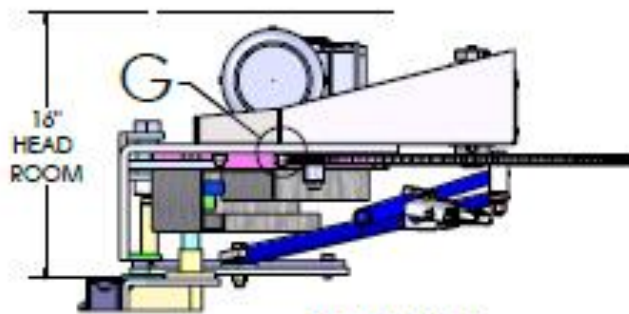

SECTION H-H
SCALE 1 : 12

Appendix: R2 Operator Layout

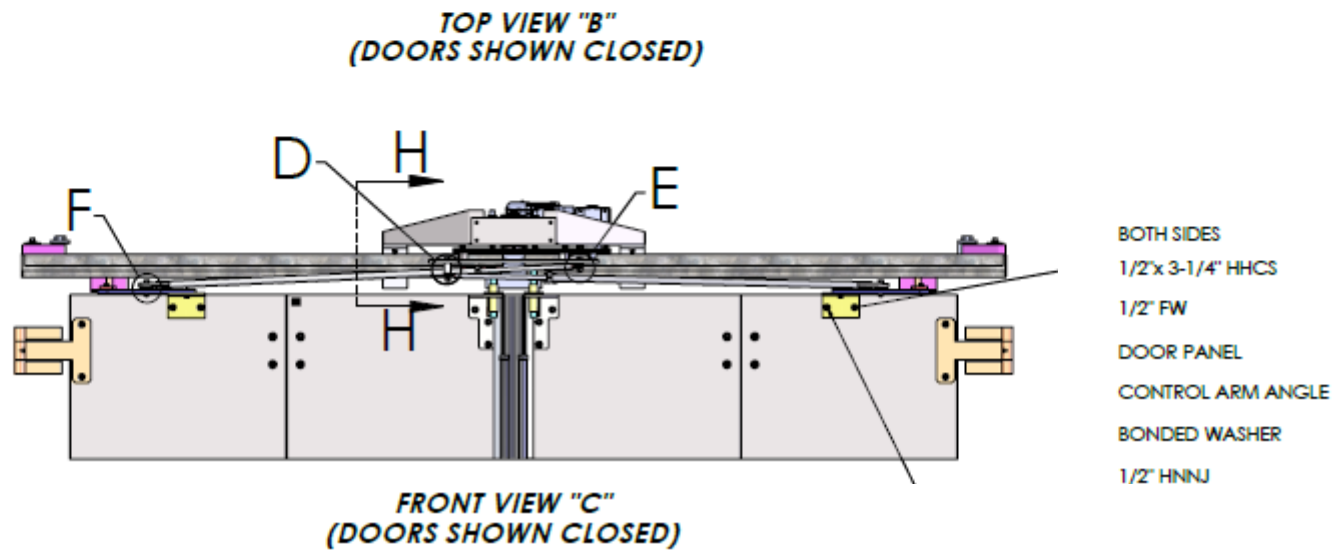
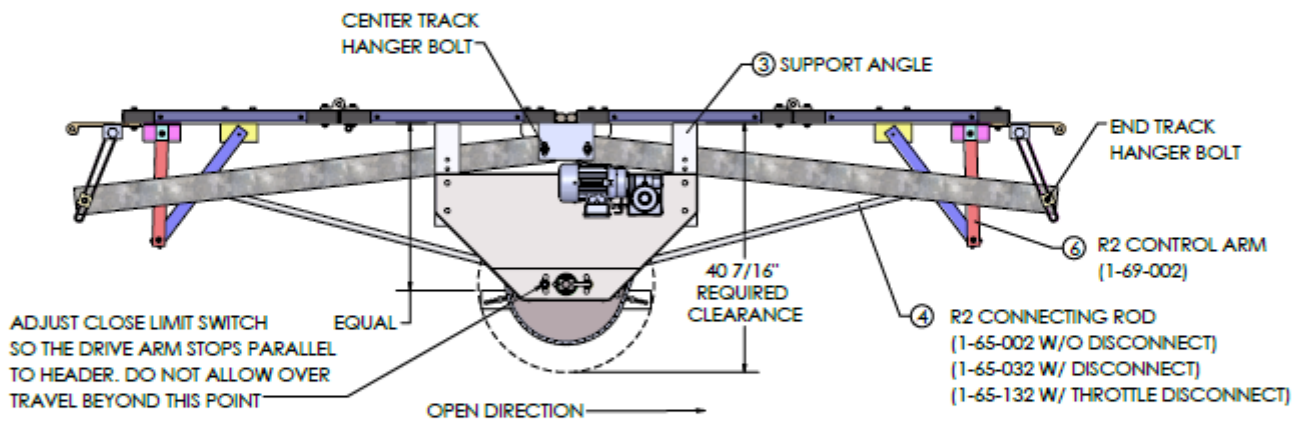
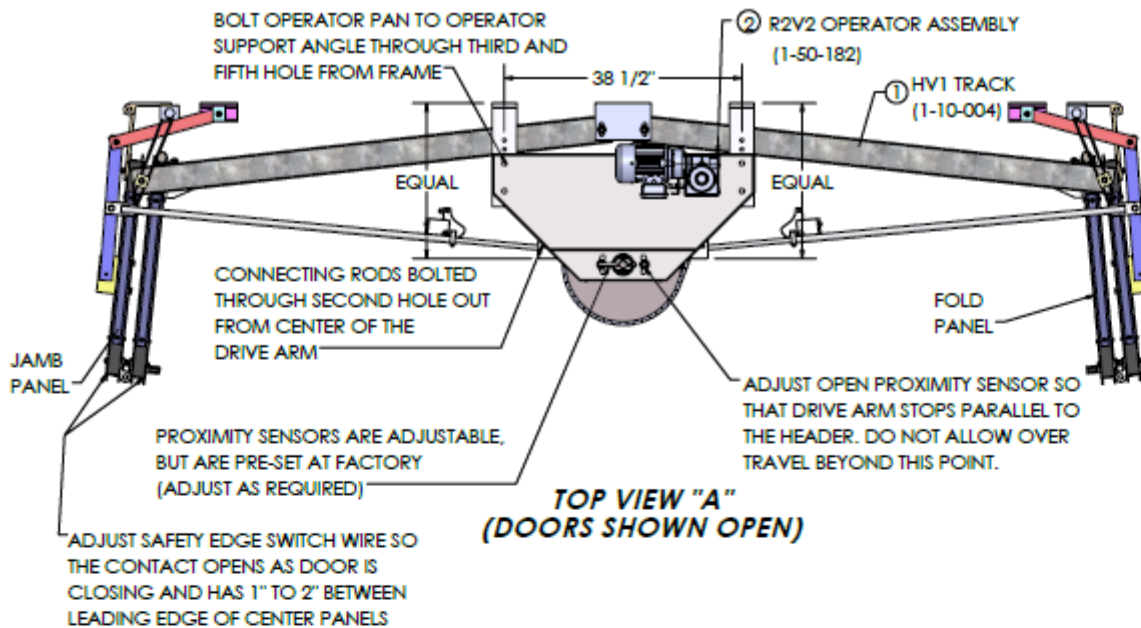

1/2" x 3-1/2" LG HHCS
R2 DRIVE ARM
R1 STANDOFF (1-66-001)
CONNECTING ROD
LW 1/2"
HN 1/2"

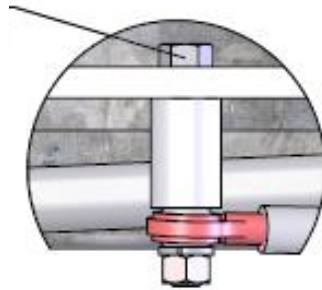

DETAIL D
SCALE 1 : 3

1/2" x 2" LG HHCS
R2 DRIVE ARM
1/2" LW
1/2" LW
CONNECTING ROD
LW 1/2"
HN 1/2"

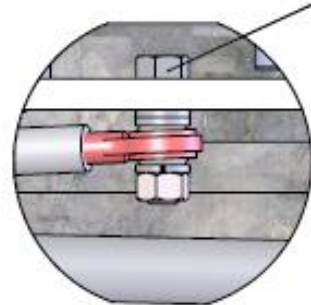

DETAIL E
SCALE 1 : 3

1/2" x 2 1/4" LG HHCS
LW 1/2"
CONNECTING ROD
LW 1/2"
CONTROL ARM
HN 1/2"

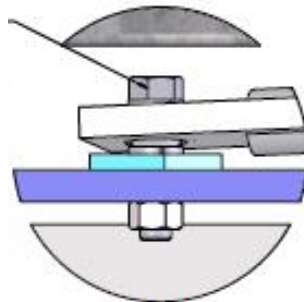

DETAIL F
SCALE 1 : 3

1/2" x 1-1/2 HHCS
OPERATOR ASSEMBLY
SUPPORT ANGLE
LW 1/2"
HN 1/2"

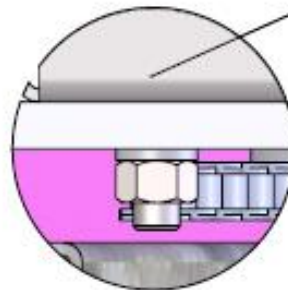

DETAIL G
SCALE 1 : 2

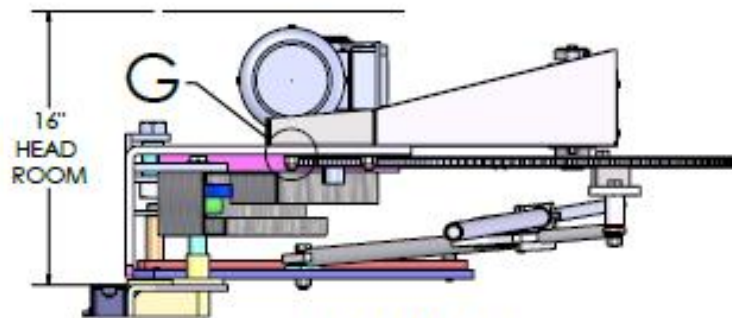

SECTION H-H
SCALE 1 : 12

Appendix: R3 Operator Layout

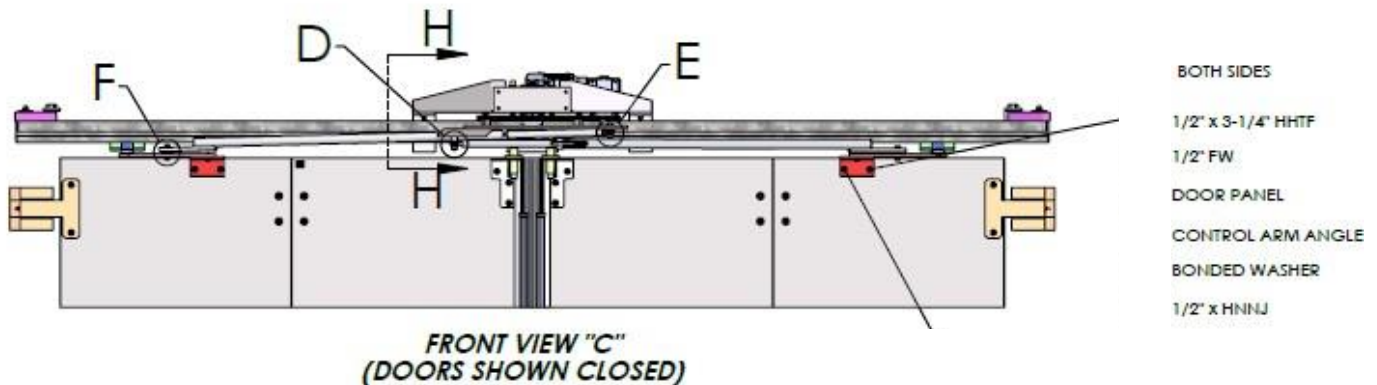
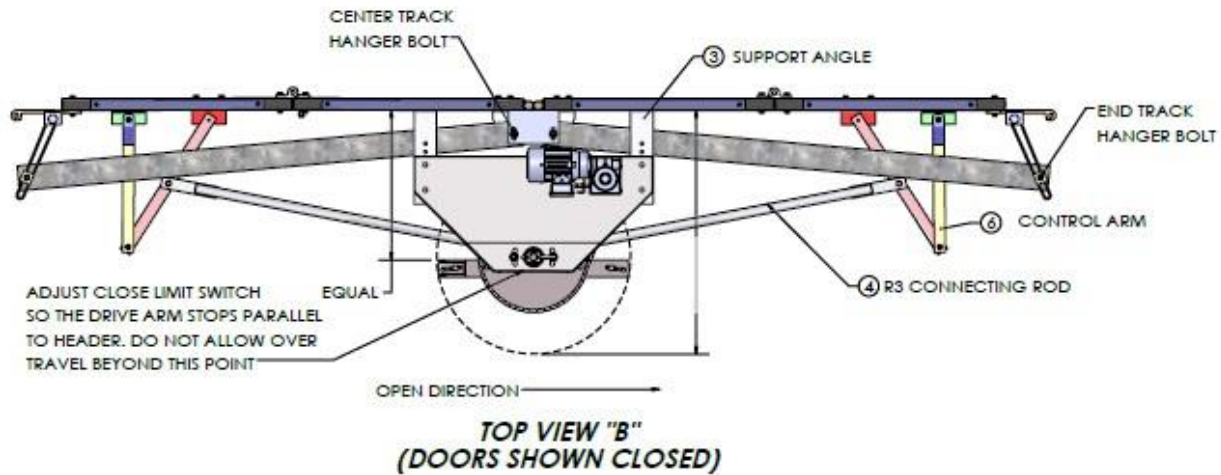
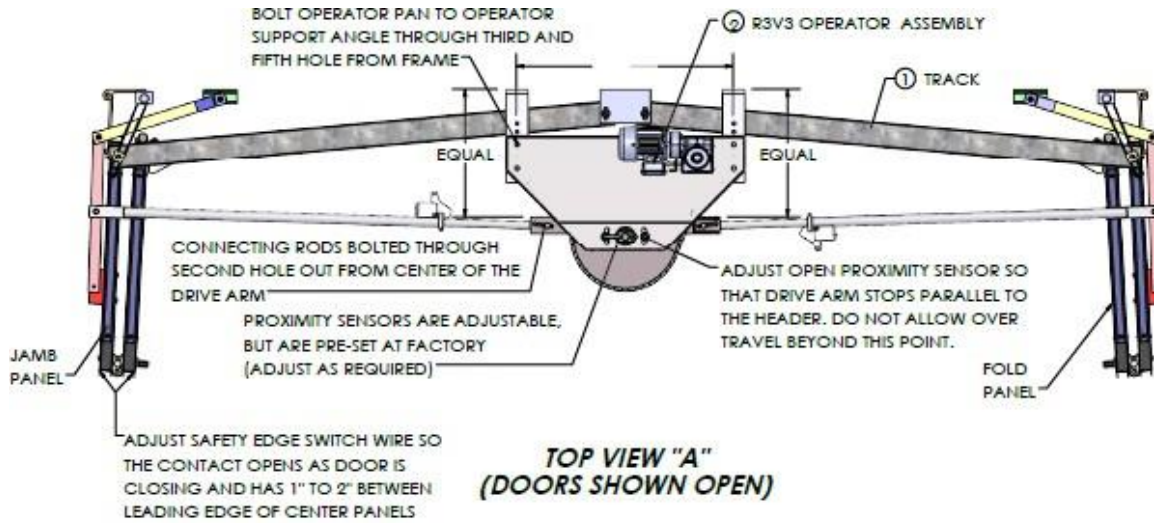

5/8" x 3" LG HHCS
R3 DRIVE ARM
R3 STANDOFF (1-66-003)
LW 5/8"
CONNECTING ROD
LW 5/8"
HN 5/8"

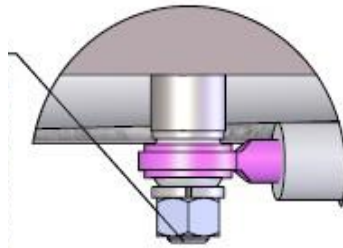

DETAIL D
SCALE 1 : 3

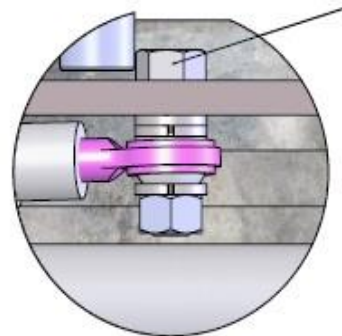

DETAIL E
SCALE 1 : 3

5/8" x 2-1/4" LG HHCS
R3 DRIVE ARM
5/8" LW
5/8" LW
CONNECTING ROD
LW 5/8"
HN 5/8"

1/2" x 2 1/4" LG HHCS
CONNECTING ROD
LW 1/2"
CONTROL ARM
LW 1/2"
HN 1/2"

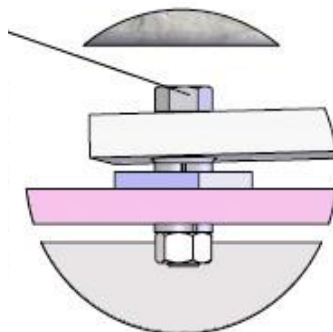

DETAIL F
SCALE 1 : 3

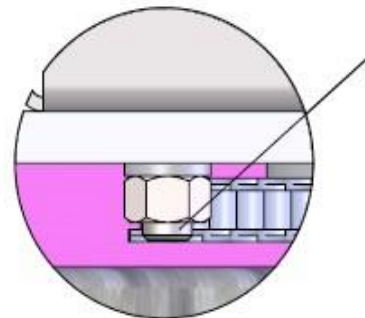

DETAIL G
SCALE 1 : 2

1/2" x 1-1/2" HHCS
OPERATOR ASSEMBLY
OPERATOR SUPPORT
LW 1/2"
HN 1/2"

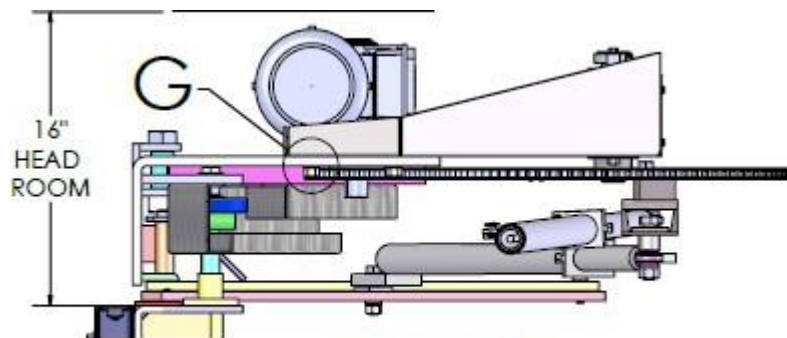

SECTION H-H
SCALE 1 : 12

Appendix: R3.5 Operator Layout

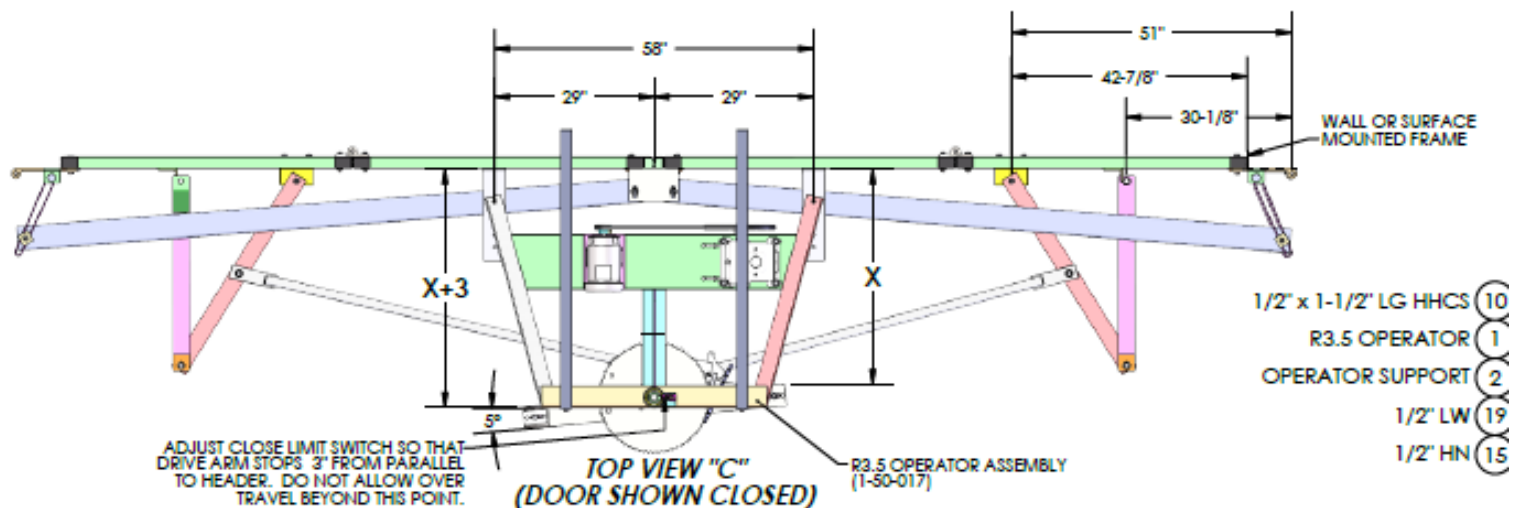
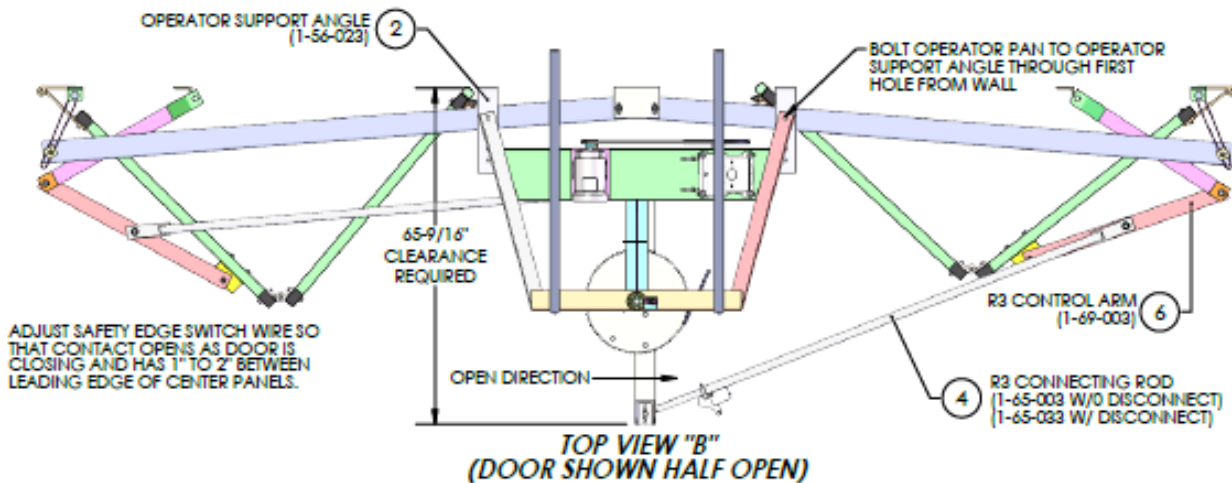
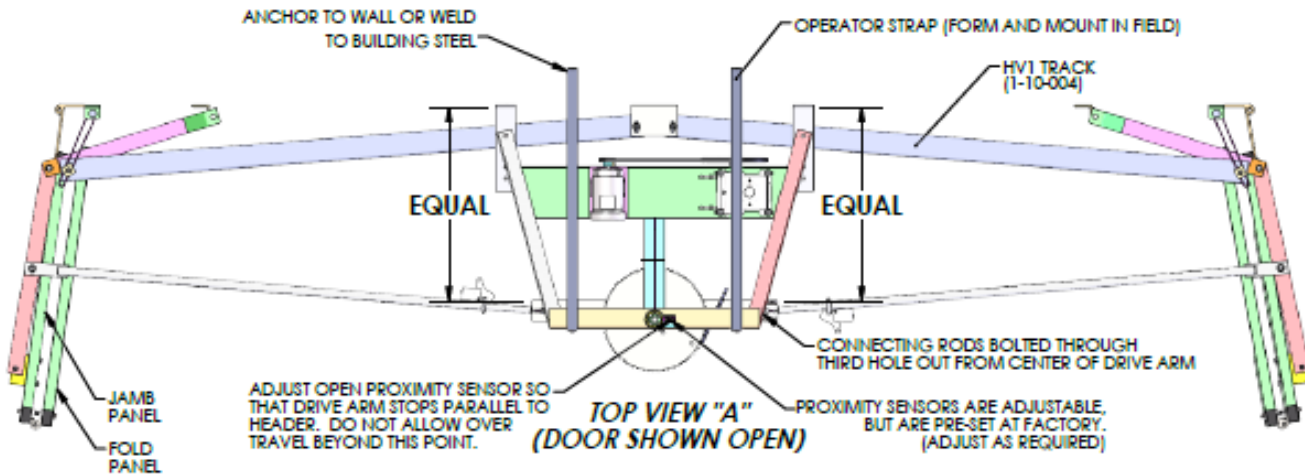

Appendix: XT Operator Layout

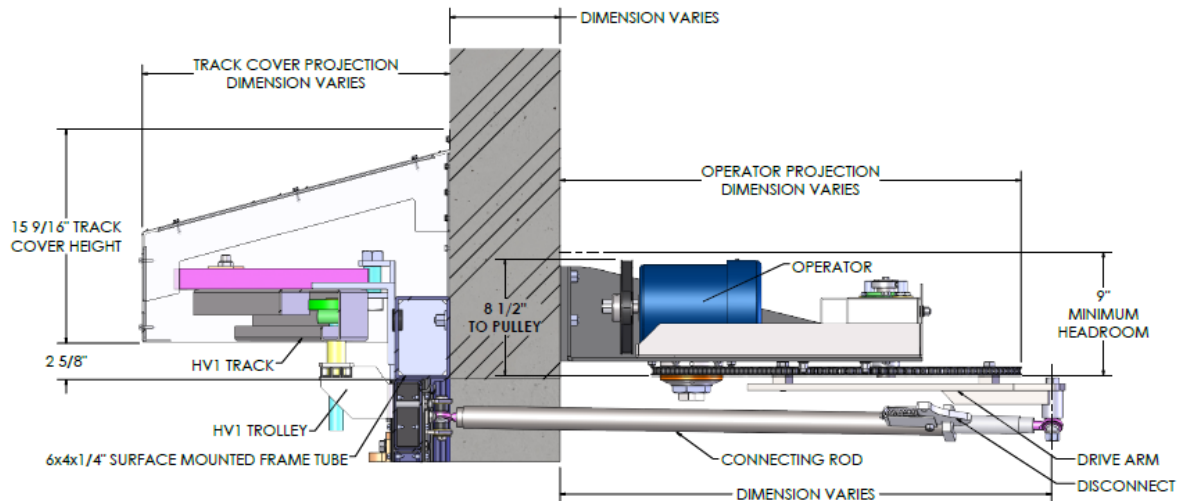
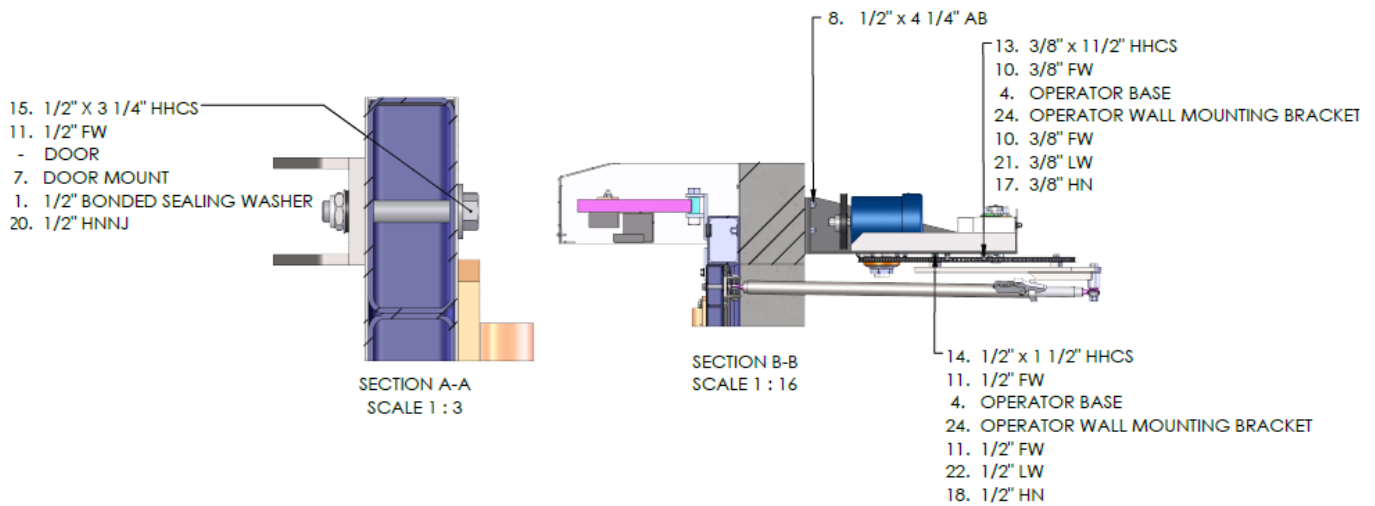
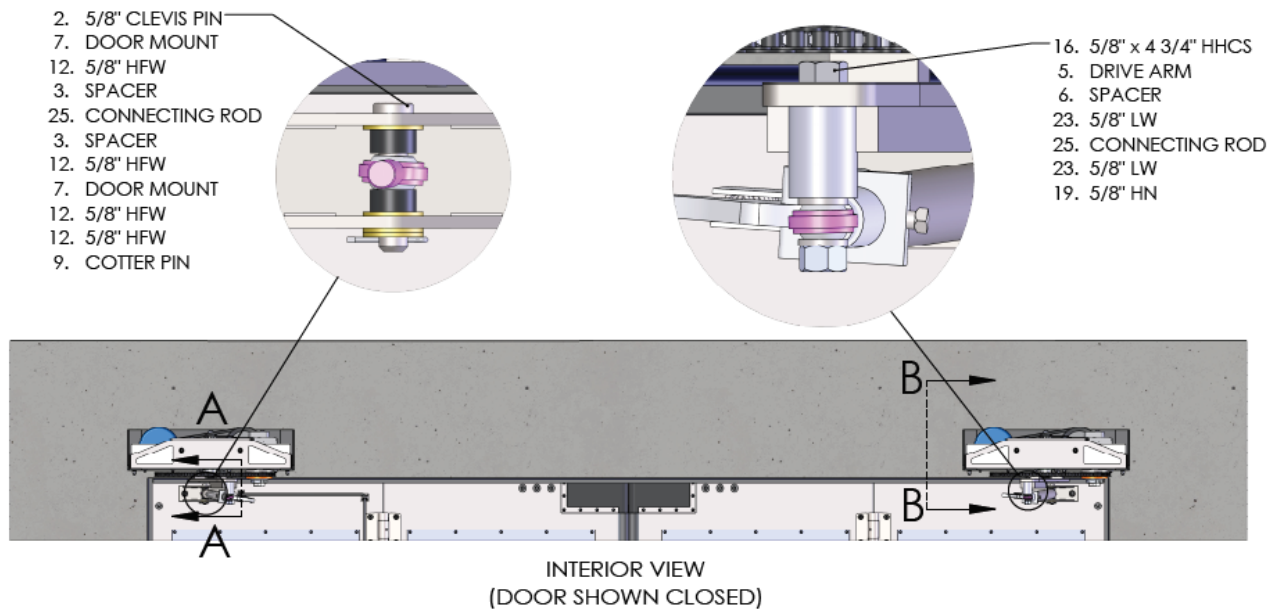

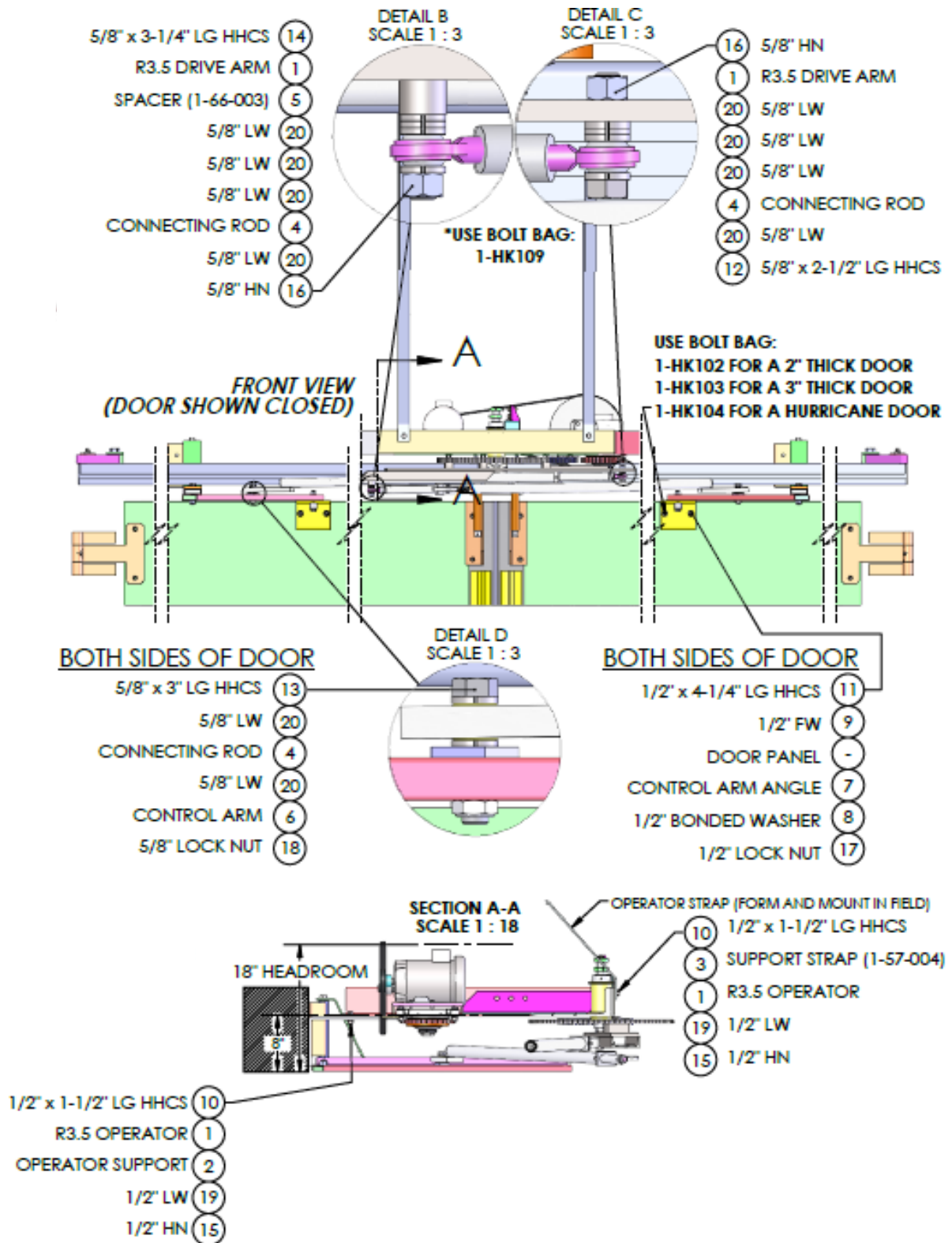

**This Page Intentionally
Left Blank**

 **WARNING****To reduce the risk of SEVERE INJURY or DEATH to persons or damage to the door system**

- Safety precautions should be always followed.
- When servicing, always disconnect Operator from main power supply and ensure proper use of “Lockout/Tagout” procedures.
- Ensure use of proper wire gauge being used for incoming power line as well as for all device connections.
- The cord fitting for main power cable coming into control panel shall be separate from the motor or any other device.
- Always separate low and high voltage wires in separate conduits. High voltage frequencies may interfere with low voltage wires.
- The Operator should be properly grounded to the building ground and to the main power supply ground lug.
- Always use the appropriate rated circuit breakers for Operator protection.
- Before electrical connection, compare the incoming power supply voltage to the voltage on the Control Panel name plate. Failure to connect appropriate power supply voltage may cause serious damage to the Operator.
- Inspections, service, and repairs should be performed anytime a malfunction is observed or suspected.
- Only qualified persons should perform maintenance on a Door Operator, and all safety precautions should be taken into consideration.
- Do not manually disconnect Connecting Rods unless power has been locked out.
- Do not attempt to make Limit Switch adjustments unless power has been locked out
- Always test the door travel after adjustment with the controls in “Hand” mode to verify desired travel. Failure to do so may result in damage to the door or injury to persons.

Limited Warranty



Door Engineering and Manufacturing, LLC warrants that all products manufactured by it shall be free from defects in materials and workmanship for a period of one (1) year from thirty (30) days of the date of shipment of product from Door Engineering and Manufacturing. Door Engineering and Manufacturing's obligation under said warranty is to cover the door and mechanical components for five

(5) years, liquid & prime paint one (1) year (excluding fading and normal wear), electrical and safety

components for one (1) year, weather seals and brake pads for one (1) year and labor one (1) year. Materials will be covered in the repair or replacement of products proven to be defective in material or workmanships.

Under said warranty, Door Engineering and Manufacturing must receive back supposed defective part within thirty (30) days of discovery and allowed to properly investigate part to determine if defective. If said part is proven to not be defective, said warranty will not be applicable and Partner will be responsible for all costs incurred. Said warranty excludes any materials which require repair or replacement due to normal wear and operation or abuse.

This limited warranty excludes any Product defects or failures caused after shipment by:

- Improper installation (including, without limitation, misalignment)
- Use in improper applications or conditions or in conjunction with improper materials (including, without limitation, improper lubricants, pastes, solvents or sealants)
- Contact with aggressive chemical agents
- Structural shifting of building
- U.V. Degradation
- Failure to adhere to Door Engineering and Manufacturing's instructions concerning the proper handling, installation, and use of the Product
- Failure to adhere to applicable standards set forth by local laws, codes, or regulations and the applicable industry standards
- Any other improper activities not listed above, or damage caused by the fault or negligence of anyone other than Door Engineering and Manufacturing

LIMITATION OF LIABILITY

THE WARRANTIES IN THIS LIMITED WARRANTY ARE THE ONLY WARRANTIES APPLICABLE TO THE PRODUCTS. THERE ARE NO OTHER WARRANTIES, REPRESENTATIONS OR CONDITIONS OF ANY KIND, EXPRESS OR IMPLIED, STATUTORY OR OTHERWISE, WITH RESPECT TO THE PRODUCTS SUPPLIED HEREUNDER INCLUDING, WITHOUT LIMITATION, ANY IMPLIED WARRANTIES OF MERCHANTABILITY OR FITNESS FOR A PARTICULAR PURPOSE. ALL SUCH WARRANTIES ARE HEREBY SPECIFICALLY DISCLAIMED. DOOR ENGINEERING AND MANUFACTURING SHALL NOT BE LIABLE IN THIS RESPECT NOTWITHSTANDING DOOR ENGINEERING AND MANUFACTURING'S ACTUAL KNOWLEDGE OF THE PRODUCT'S INTENDED USE OR ANY ADVICE OR REPRESENTATIONS THAT MAY HAVE BEEN RENDERED BY DOOR ENGINEERING CONCERNING THE DESIGN, MANUFACTURE, FABRICATION, SALE, USE, INSTALLATION OR PROVISION OF THE PRODUCTS. NO STATEMENT, CONDUCT OR DESCRIPTION BY DOOR ENGINEERING AND MANUFACTURING OR ITS REPRESENTATIVES, IN ADDITION TO OR BEYOND THIS LIMITED WARRANTY, SHALL CONSTITUTE A WARRANTY.

THE SOLE AND EXCLUSIVE REMEDY FOR BREACH OF THIS LIMITED WARRANTY, AND THE SOLE AND EXCLUSIVE OBLIGATION OF DOOR ENGINEERING AND MANUFACTURING IN RESPECT OF ANY CLAIMS FOR BREACH OF THIS LIMITED WARRANTY, SHALL BE, AT DOOR ENGINEERING AND MANUFACTURING'S SOLE DISCRETION, (1) THE REPLACEMENT OF THE SAME TYPE, SIZE AND LIKE QUANTITY OF NON- DEFECTIVE PRODUCT, AT THE ORIGINAL POINT OF DELIVERY, OR CREDIT, OR A COMBINATION THEREOF, FOR THE WHOLESALE PURCHASE PRICE OF THE DEFECTIVE PRODUCT. IN NO EVENT SHALL DOOR ENGINEERING AND MANUFACTURING BE LIABLE FOR PERSONAL INJURY, LOST PROFITS, LOSS OF GOODWILL, LOSS OF BUSINESS OPPORTUNITIES, DAMAGE TO REPUTATION, SPECIAL DAMAGES, INDIRECT DAMAGES, DELAY DAMAGES, PUNITIVE DAMAGES, INCLUDING WITHOUT LIMITATION ANY COSTS INCURRED IN CONNECTION WITH THE REMOVAL OR REINSTALLATION OF ALLEGEDLY DEFECTIVE PRODUCTS.

Limited Warranty cont.



CLAIMS

Every claim under this warranty shall be void unless it is made in writing and received by Door Engineering and Manufacturing within thirty (30) days of the date the defect was discovered and, in any event, within one (1) year of the date of invoice. Claims for Product defects that affect the appearance of the Product, such as U.V. degraded Product, however, must be made within thirty (30) days of the date of the receipt of the Product. No claim under this limited warranty will be valid unless:

- Proof of purchase with the date thereof as well as a description of the alleged defect in reasonable detail is presented to the satisfaction of Door Engineering and Manufacturing LLC,
- Written Permission and/or Return Material Authorization (RMA) is obtained from Door Engineering and Manufacturing LLC,
- Door Engineering and Manufacturing is given an opportunity to inspect the allegedly defective product, and
- At Door Engineering and Manufacturing's request, representative samples of the allegedly defective Product are returned to Door Engineering and Manufacturing in accordance with company instructions.

GENERAL

In the event that any provision of this limited warranty is held to be illegal or unenforceable by any court of competent jurisdiction, the remaining provisions of this limited warranty shall remain in full force and effect. This limited warranty shall be governed by the laws of Minnesota, without regard to such state's conflicts of law principles that would require the application of the law of any other jurisdiction. Any and all disputes arising out of or relating to this limited warranty shall be subject to the exclusive jurisdiction of the state or federal courts located in the state of Minnesota or, at Door Engineering and Manufacturing's sole election, to binding arbitration before a single arbitrator pursuant to the American Arbitration Association's Commercial Dispute Resolution Procedures, with such arbitration to take place in the state of Minnesota. Door Engineering and Manufacturing reserves the right to revise this Limited Warranty and Limitation of Liability without notice at any time.

This limited warranty may only be modified or altered in a writing signed by the President of Door Engineering and Manufacturing



Opening to Your Standards