

HERCULES®

— A SENNECA COMPANY —

INFITTING & OVERLAP HINGED DOORS

INSTALLATION MANUAL

OUR COMPLETE LINE



Vertical Lift



Bi-Parting Sliding



Hinged-Infit & Overlap



Horizontal Sliding



TESTED & APPROVED



BUILDING
CERTIFICATION &
GREEN TARGETS



INDOOR
ENVIRONMENTAL
QUALITY



LIFE-CYCLED BENEFITS

CONTENTS

I. Important Notice	4
Figure 1: Infitting Door with Flush Sill	5
Figure 2: Infitting Door with High Sill	6
Figure 3: Overlap Door with Flush Sill	7
Figure 4: Overlap Door with High Sill	8
Figure 5: Double Infitting Door with Flush Sill	9
Figure 6: Double Infitting Door with High Sill	10
II. Installation Procedure	13
1. Installing Door	13
2. Electrical hookup of heat circuits (for freezer applications only)	15
3. Final Inspection	15
III. General Maintenance	17
IV. Troubleshooting Malfunctions & Problems	19
V. Parts List	
Parts Figure 1: Heater Details for Infitting Door with Flush Sill	20
Parts Figure 2: Heater Details for Infitting & Overlap Door with High Sill	21
Parts Figure 3: Gasket Assembly for Infitting Doors	22
Parts Figure 4: Gasket Assembly for Overlap Doors	23
Parts Figure 5: Hinge Assembly for Infitting Doors	24
Parts Figure 6: Latch Assembly for Infitting Door	24
Parts Figure 7: Hinge Assembly for Overlap Doors	25
Parts Figure 8: Latch Assembly for Overlap Doors	25
Parts Figure 9: Outside Release Assembly for Overlap Doors	26
Parts Figure 10: Inside Release Assembly for Overlap Doors	27



IMPORTANT NOTICE

Before beginning installation, please read this manual in its entirety.

This door has been designed and built to provide years of trouble-free service in heavy duty commercial and warehouse operations. This Installation Manual may be used for all of the following door types:

- Infitting Door with Flush Sill
- Infitting Door with High Sill
- Overlap Door with Flush Sill
- Overlap Door with High Sill
- Double Infitting Door with Flush Sill
- Double Infitting Door with High Sill

Reference to the following figures will provide general specifications for your model. Sub-assemblies are provided for rapid installation and adjustment.

INFITTING DOOR WITH FLUSH SILL

Figure 1

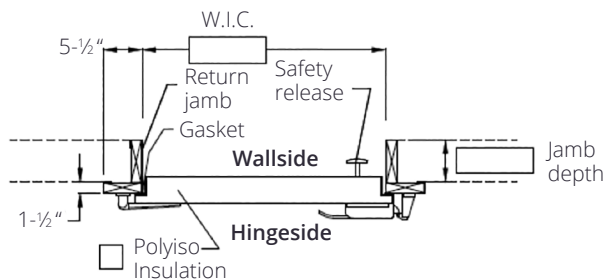
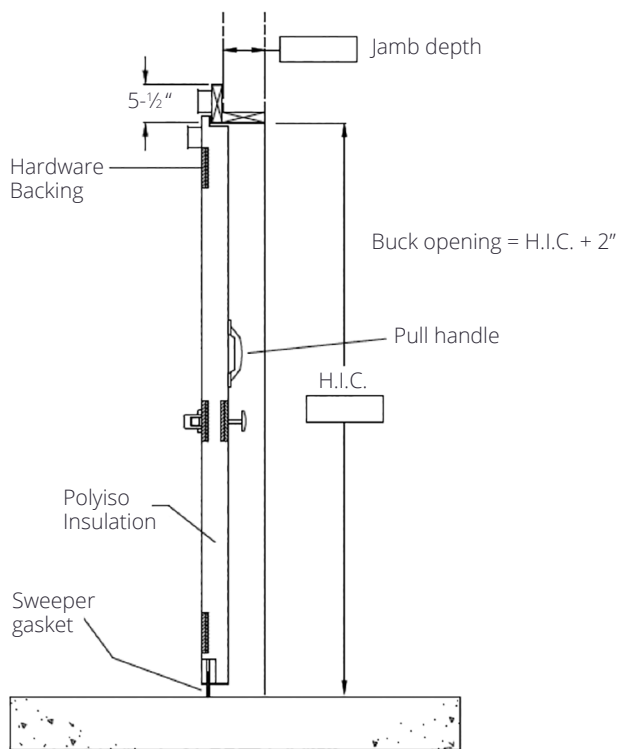
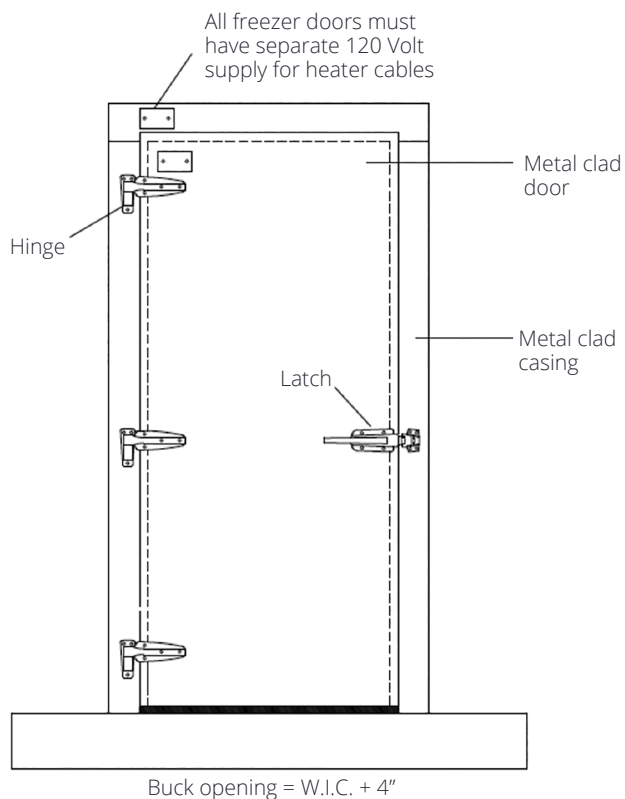

Note: Left swing shown, right swing opposite.

Note: Heat in three (3) sides of frame and in bottom of door (freezers only)

Note: Doors 60' x 84' and over will be required to use a floor roller with non-camlift hinges

INFITTING DOOR WITH HIGH SILL

Figure 2

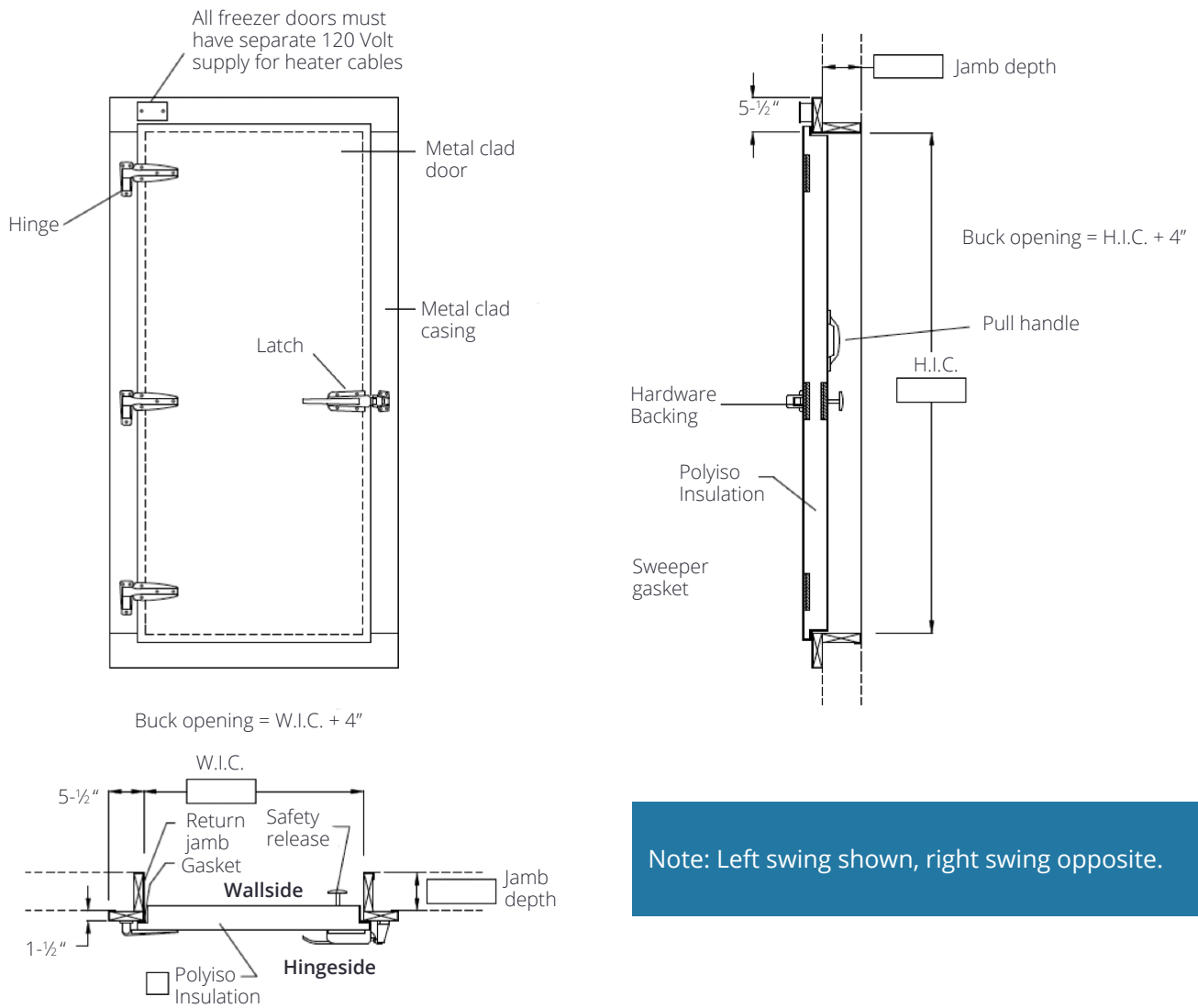

OVERLAP DOOR WITH FLUSH SILL

Figure 3

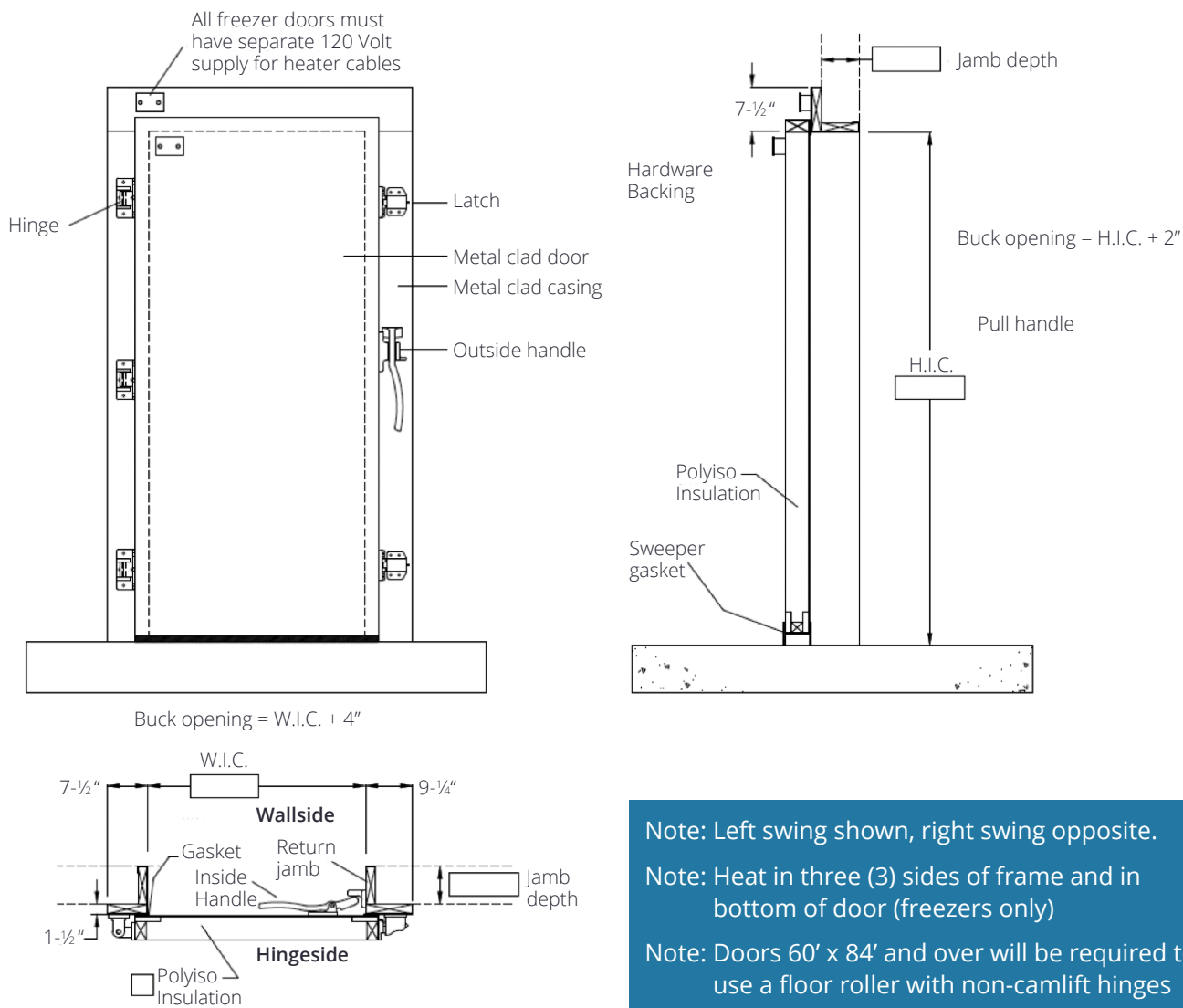

Note: Left swing shown, right swing opposite.
 Note: Heat in three (3) sides of frame and in bottom of door (freezers only)
 Note: Doors 60' x 84' and over will be required to use a floor roller with non-camlift hinges

OVERLAP DOOR WITH HIGH SILL

Figure 4

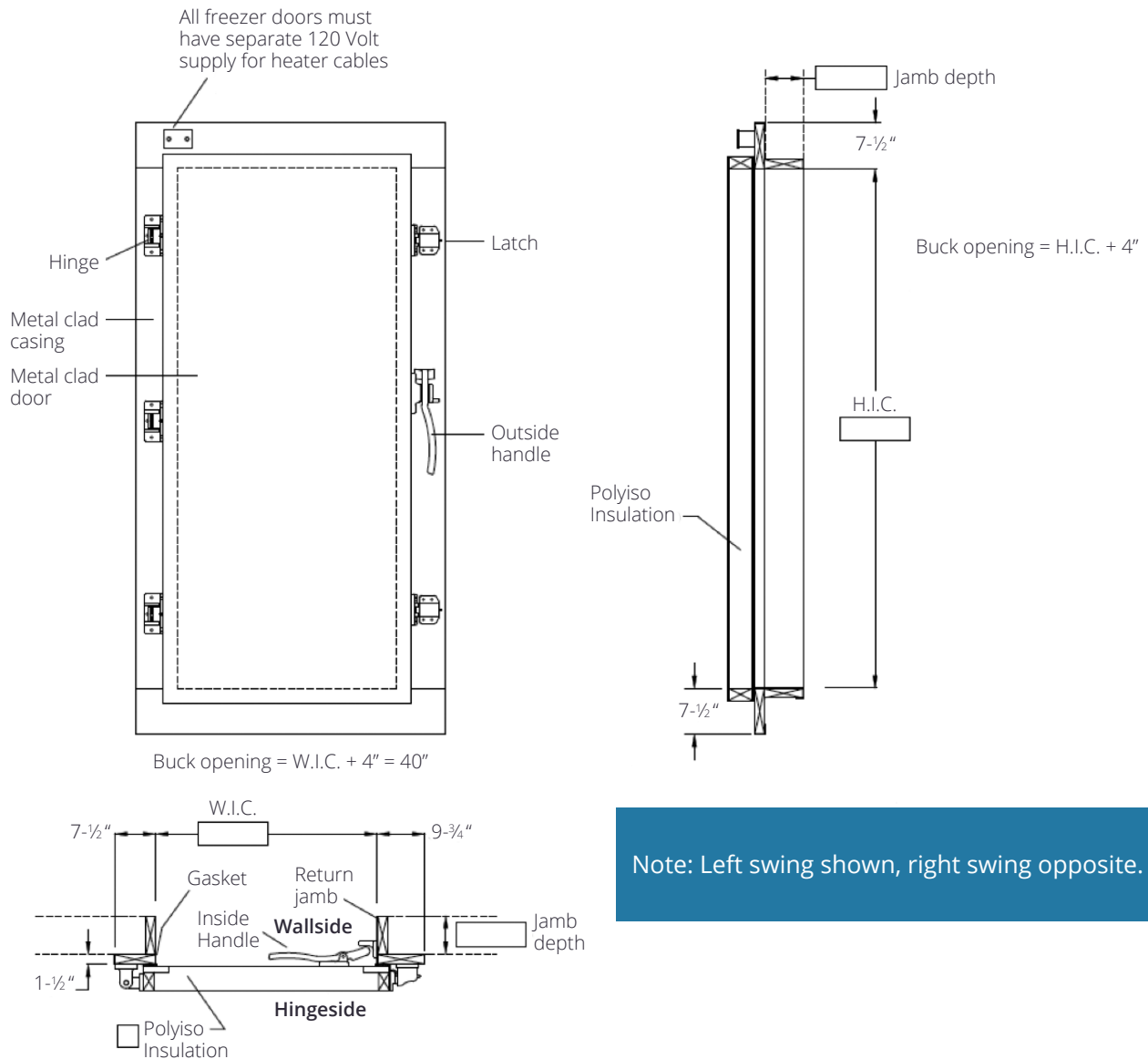

DOUBLE INFITTING DOOR WITH FLUSH SILL

Figure 5

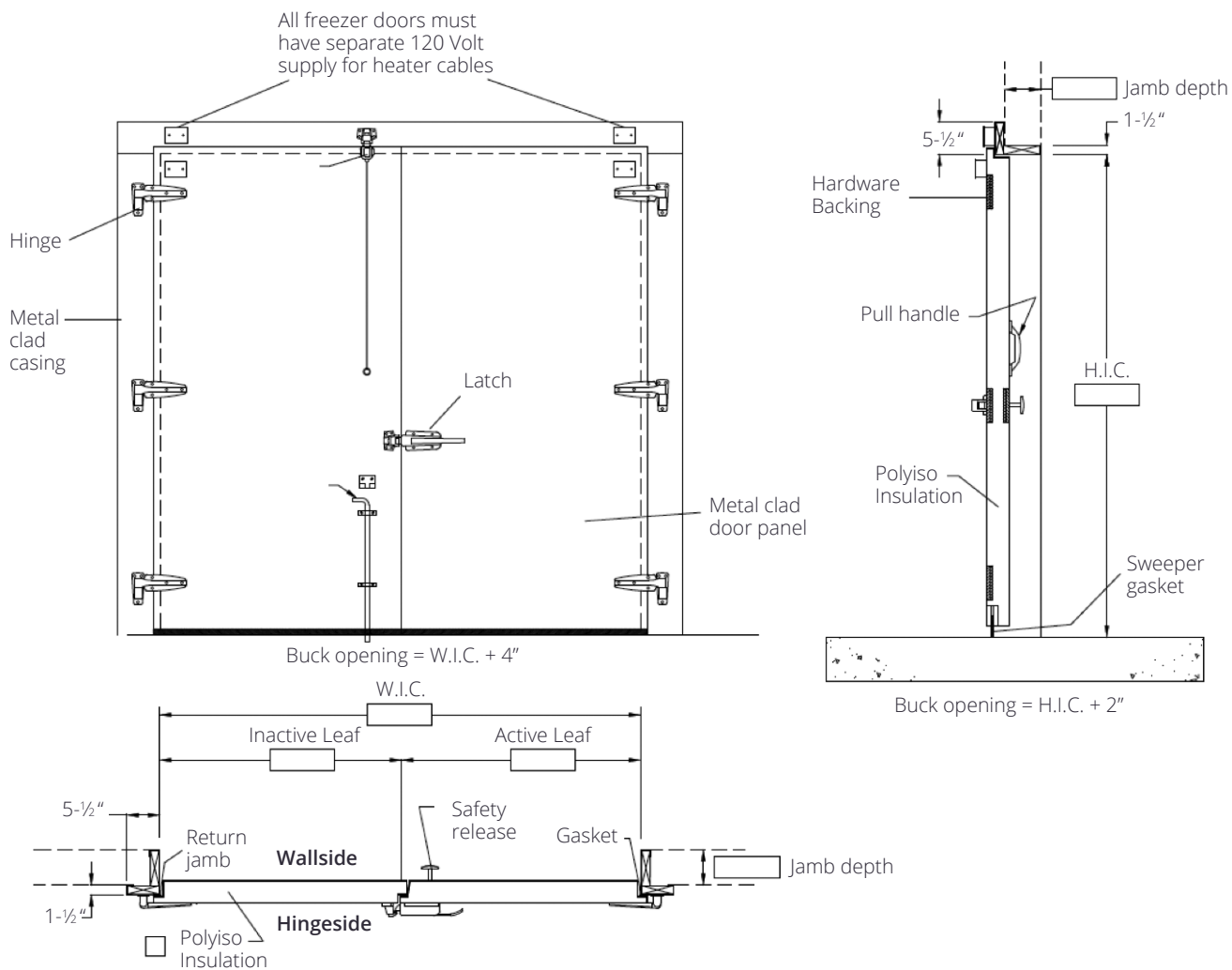

DOUBLE INFITTING DOOR WITH HIGH SILL

Figure 6

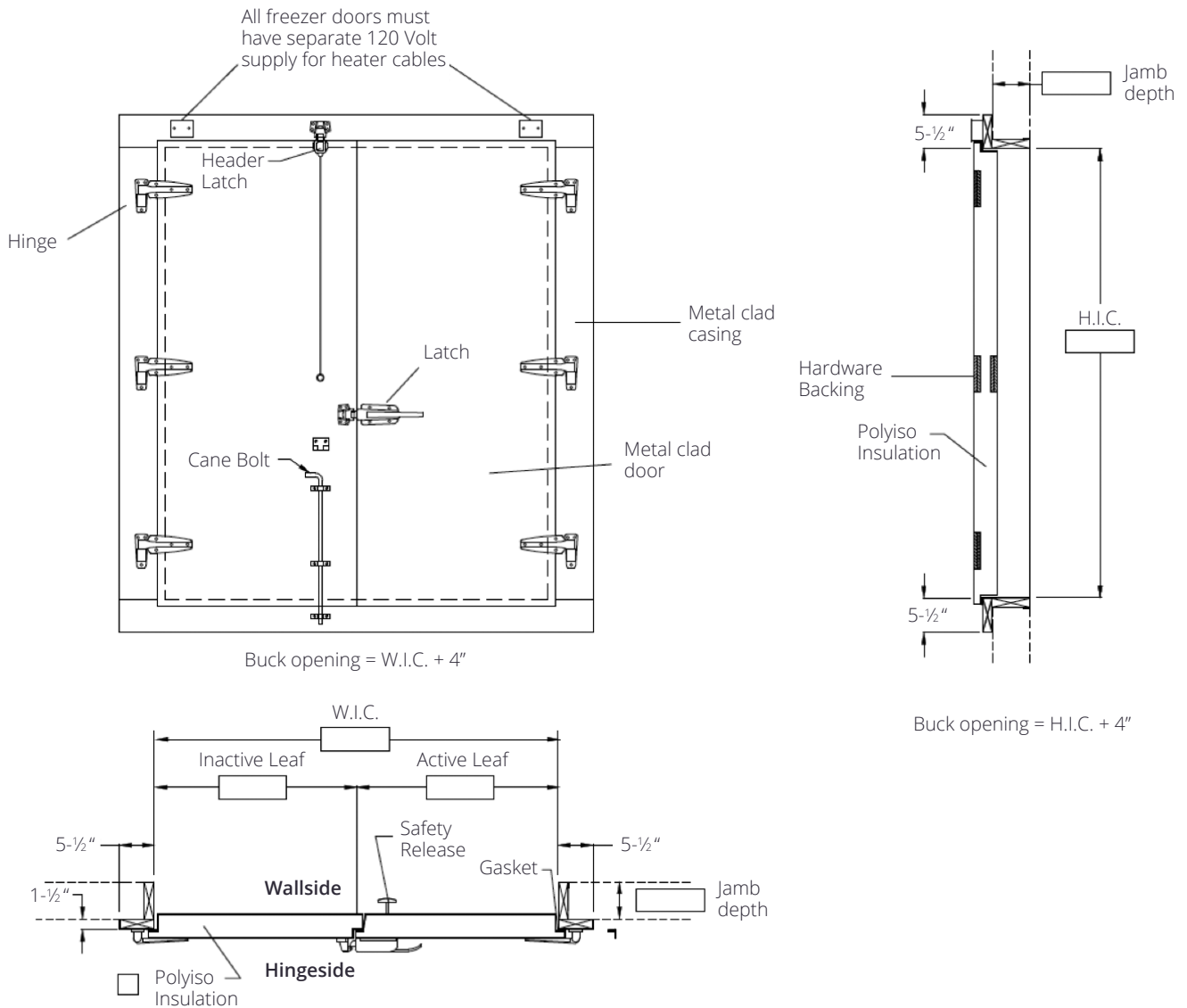





INSTALLATION PROCEDURE

I. Installing Door

- The opening of the door frame must be plumb, level and square.**
- Apply Butyl caulk to the back of the door frame to provide a seal between the frame and the wall before installing the frame in the opening as shown in **Figures 8-9** on page 14.
- If the floor slopes, start by setting the high side of the door frame first and shim to raise the other side so that the top of the door frame opening is level.

Note: Ensure the door is level in the opening of the frame.

- Plumb as shown in **Figure 7** and attach securely to door bucks. Make sure the inside of the door frame is plumb and square to ensure proper sealing of the door against the frame.
- Before mounting all bolts in frame, hang the door in the frame and check position of latch & strike (Door frame may need to be shifted to the left or right to level the latch to the strike).

Figure 7

Mounting door in opening

Left Side View

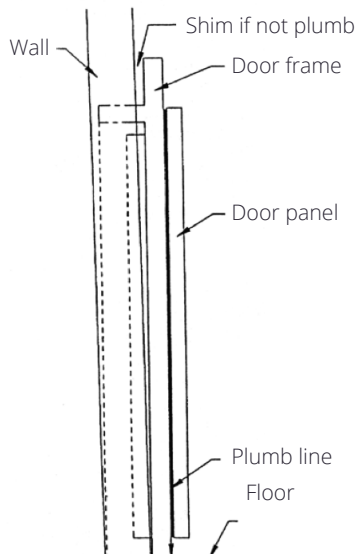

Note: If walls are not plumb and parallel, shim as required.

Top View

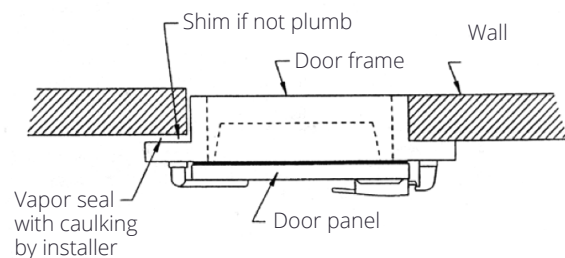

Note: If mounting walls are not on the same surface plane, shim as required.

- f) Mount frame to wall as shown in **Figures 8-9** below for frames with and without an inside casing.
- g) Once door is securely mounted apply sealant in all seams to provide vapor seal.
- h) Open door and check for freedom of movement.
- i) For flush sill doors, trim the neoprene foam gasket running down the sides at the bottom of the door so that it is flush with the floor as shown in **Figure 10**.

Figure 8

Door frame mounting - with inside casing

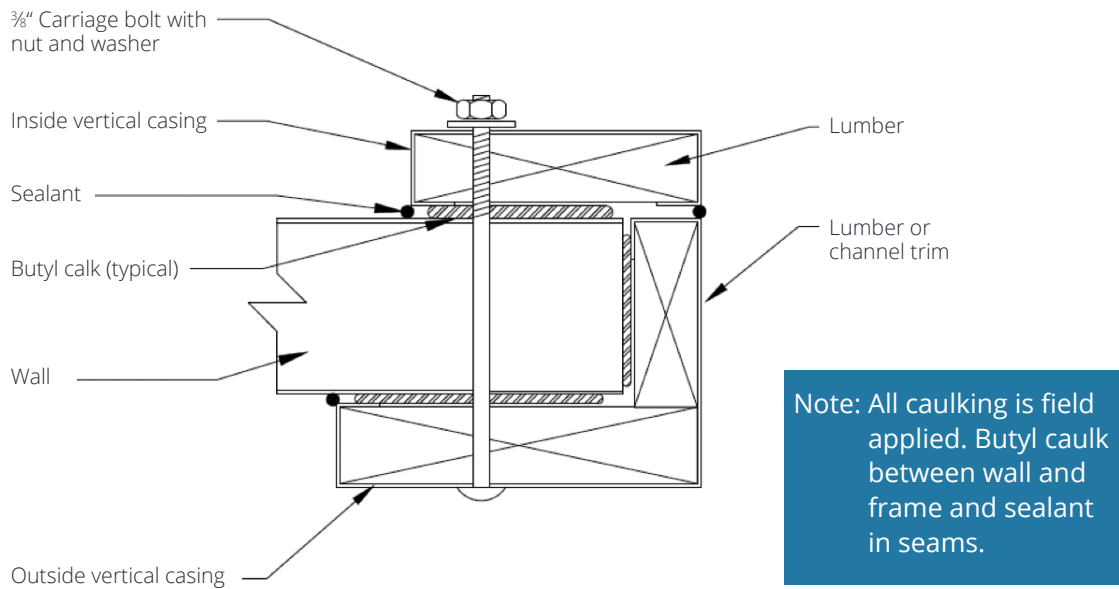

Figure 9

Door frame mounting - without inside casing

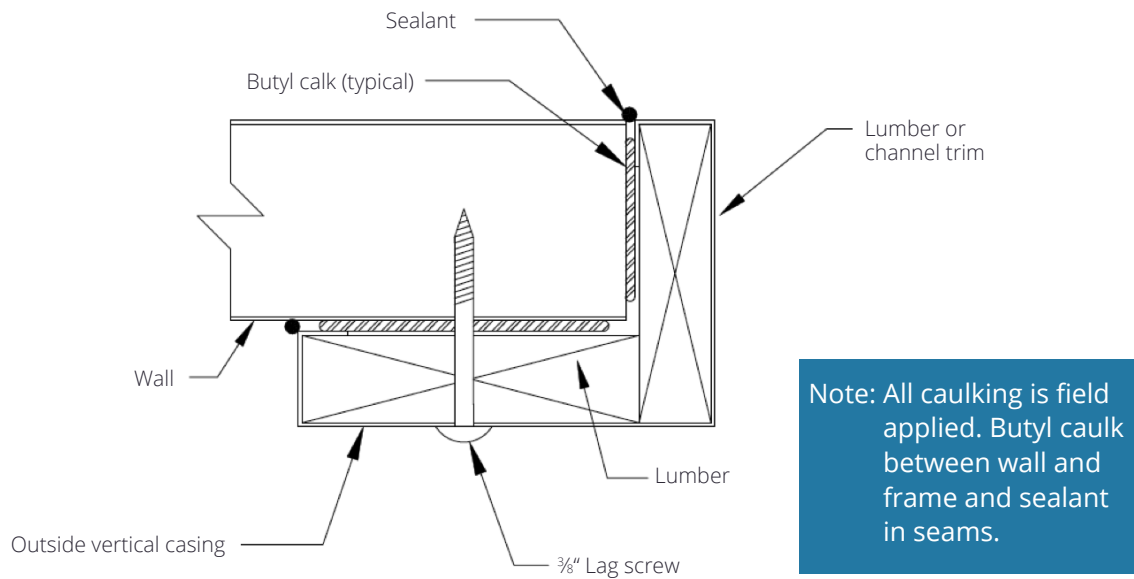
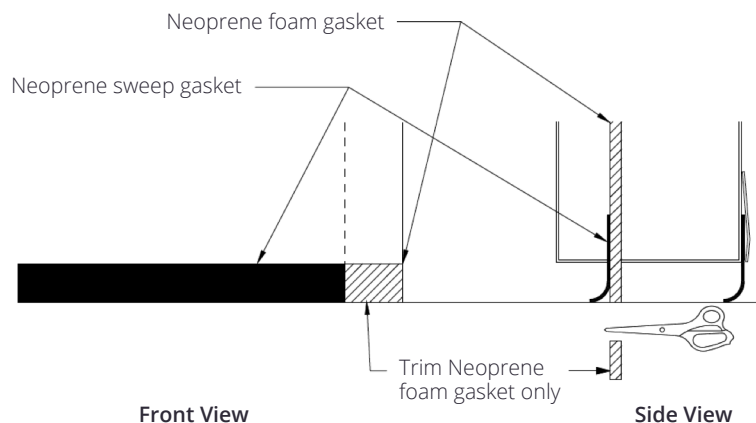

Figure 10

Neoprene foam gasket trimming



2. Electrical hookup of heat circuits (for freezer applications only)

- 1) Before proceeding, check to see that available power supply (voltage and phase) matches that on name plate located adjacent to junction box on door frame.
- 2) Consult local electrical codes before proceeding with installation.
- 3) Note: This unit must be properly grounded. A separate power supply (120V) is needed for each door.
- 4) Connect proper voltage to lead wires provided (Black, White, Green) as stated on name plate to junction box(es) mounted on door frame. (See Parts Figures 1 & 2)
- 5) If applicable, make sure that jumper cable is installed between door frame and door panel.

3. Final Inspection

- 1) **Make sure door is plumb, level and square. This is critical for proper seal.** If necessary to increase the pressure on the perimeter gasket, adjust the latch strike to the seal.
- 2) Recheck all steps above. Inspect door and frame. Make sure that door can travel freely (manually) from full closed to full open without obstruction.
- 3) When installation is complete, store this manual in a safe place for future reference.



GENERAL MAINTENANCE

a) Maintenance on door parts should be performed as specified in the table shown below:

Door Part	Time Frame	Maintenance
Lubrication	Every 6 months	The frequency of lubrication is governed by the environmental conditions at the location of the door. The self-lubricating bushings, in normal service, need not be lubricated. However, it is recommended that a few drops of light oil periodically be used on all moving parts.
Door gaskets and inner edge of door	Every 3 months	Clean gaskets to allow for smooth contact between door and gaskets. (Soap and water is recommended for cleaning)
Latches, strikes, fasteners (includes all hardware)	Every 3 months	Check and re-tighten as required.
Sealant	Every 3 months	<p>During the life of the door it is possible for the factory sealant in the seams and joints to come loose, either from abuse or normal use. It is critical that all seams and joints are kept vapor tight at all times</p> <p>Inspect seams and joints (of door, window, and frame) for loose or missing sealant. Approved sealant must be applied if replacement is necessary. Failure to do so will affect watertight integrity and cause deterioration of the door.</p> <p>Failure to maintain sealant will void the warranty.</p>

Special care must be taken in areas that are washed down with de-greasing chemicals. Electrical components must be protected and lubricants must be washed from the operator and other moving parts immediately to prevent permanent damage.

b) Reference pictures

1. Re-tightening latches, strikes etc.



2. Sealant replacement

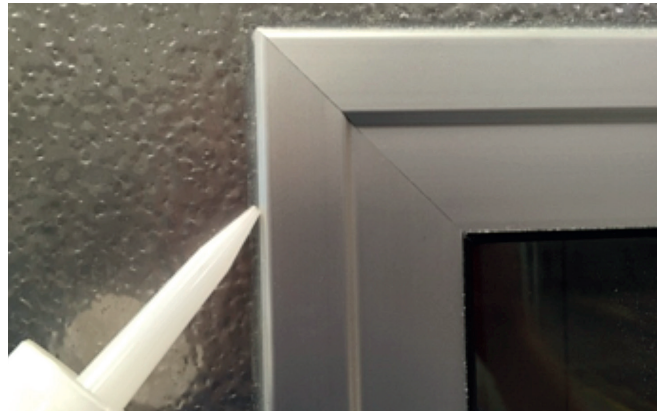

IV TROUBLESHOOTING MALFUNCTIONS & PROBLEMS

All door assemblies are thoroughly tested and inspected before leaving our factory. If a problem develops when the door is first installed, it is recommended that the installation manual be read through carefully again to determine whether an error has been made in the installation process.

If you require further assistance, please contact us at the address and phone number below:

Kingspan Insulated Panels, Inc.
726 Summerhill Drive
Deland, FL 32724-2024
Phone (386) 626-6789
E-Mail: info@kingspanpanels.us



V PARTS LIST

The Parts List is provided for your convenience when ordering replacement parts. Please use the model and serial number of your door when ordering parts, as this will expedite shipment of required parts and avoid unnecessary correspondence.

Parts Figure 1: Heater for Infitting Door with Flush Sill (Freezer only)

Detail: Heat in frame

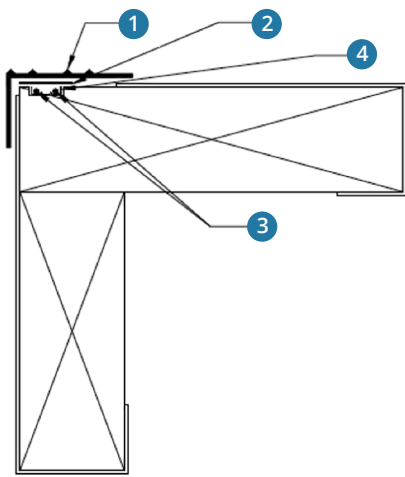

Detail: Heater cable routing

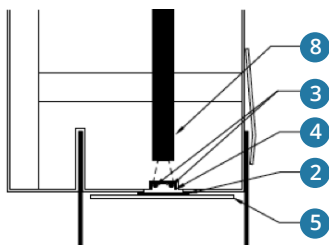
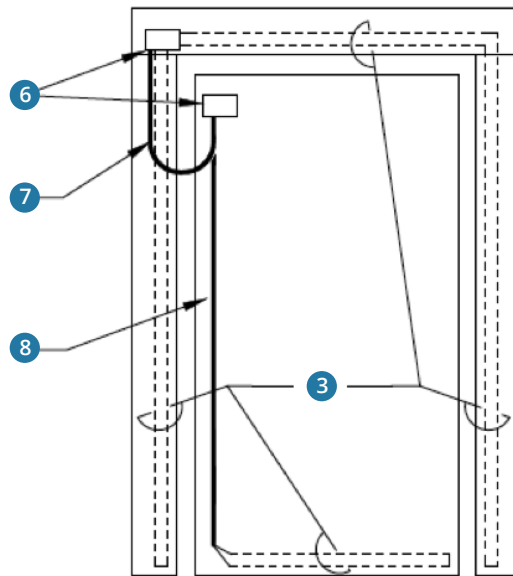

Part No	Description
1	Aluminum Heater Cover Extrusion
2	Aluminum Foil Tape
3	Heater Wire
4	Heater Wire Channel Extrusion
5	20 Ga. Galv Trim
6	Bell Box (Three Hole)
7	Jumper Cable
8	PVC Tubing

Parts Figure 2: Heater for Infitting and Overlap Door with High Sill (Freezer only)

Detail: Heat in frame

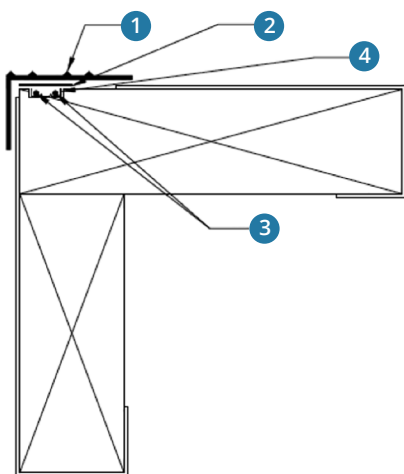

Detail: Heater cable routing

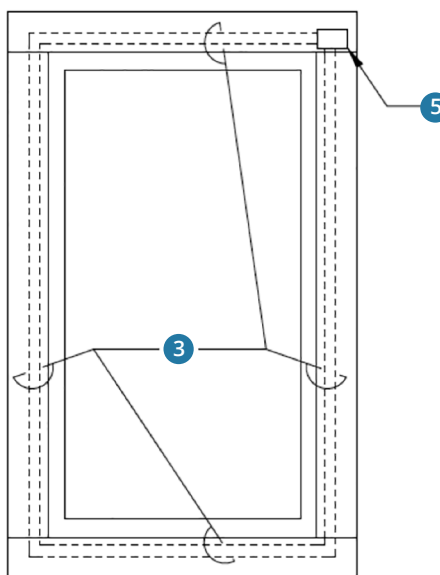

Part No	Description
1	Aluminum Heater Cover Extrusion
2	Aluminum Foil Tape
3	Heater Wire
4	Heater Wire Channel Extrusion
5	Bell Box (Three Hole)

Parts Figure 3: Gasket Assembly for Infitting Doors

Perimeter door gasket

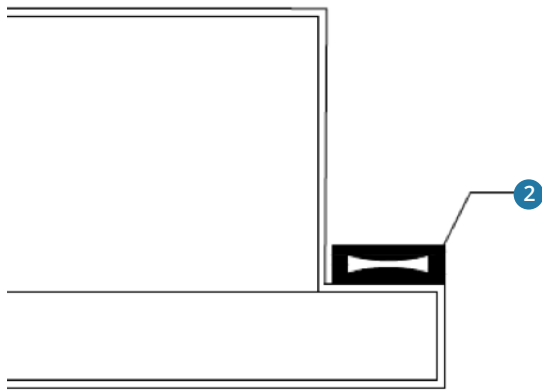

Sweep gasket - Flush sill only

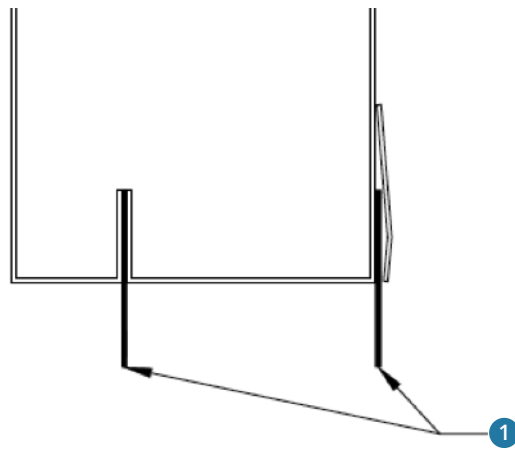

Part No	Description
1	Neoprene Sweep Gasket - 1/16" x 2"
2	Hollowcore Neoprene Gasket - 1/2" x 1 1/4"

Note:
Double sweep gasket for freezer doors only.

Parts Figure 4: Gasket Assembly for Overlap Doors

Perimeter door gasket

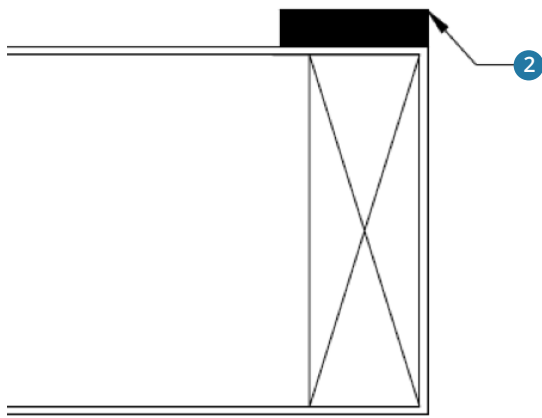

Sweep gasket - Flush sill only

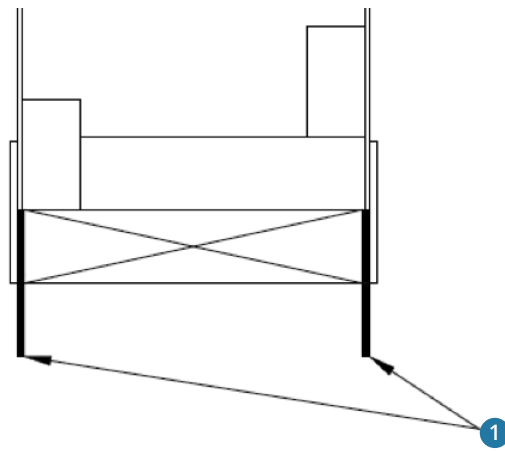

Part No	Description
1	Neoprene Sweep Gasket - 1/16" x 2"
2	Neoprene Foam Gasket - 1/2" x 3"

Parts Figure 5: Hinge Assembly for Infitting Doors

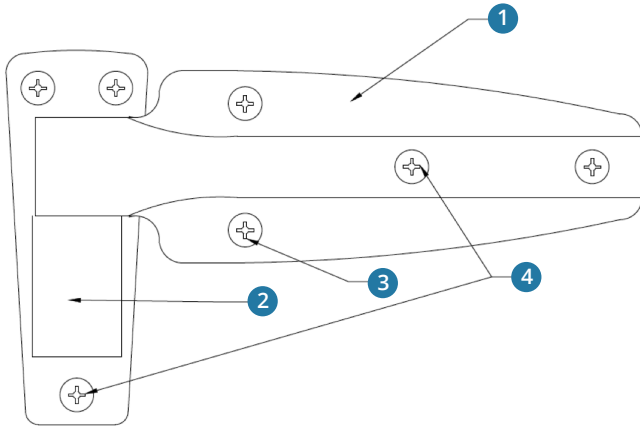

Part No	Description
1	Hinge Base
2	Hinge Butt
3	#14 x 1¼" Phillips Head Screw
4	#14 x 1¾" Phillips Head Screw

Parts Figure 6: Latch Assembly for Infitting Doors

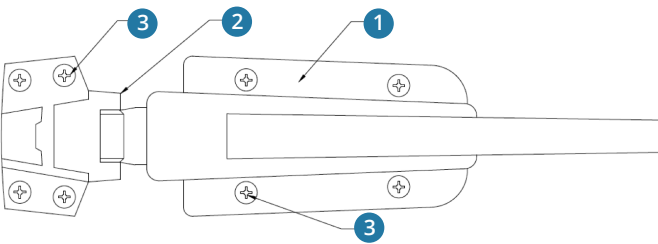

Part No	Description
1	Latch Base
2	Latch Strike
3	#14 x 1¾" Phillips Head Screw

Parts Figure 7: Hinge Assembly for Overlap Doors

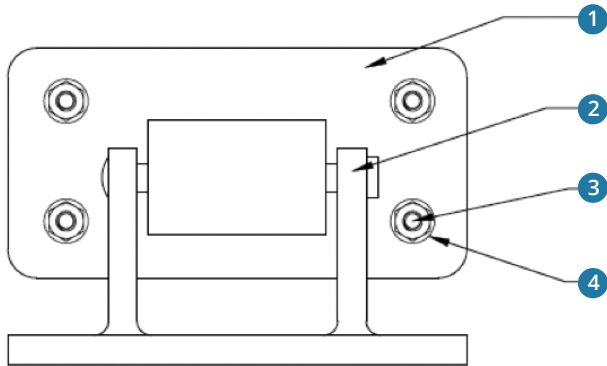

Part No	Description
1	Hinge Base
2	Hinge Butt
3	$\frac{3}{8}$ " x 2 $\frac{1}{2}$ " Cap Bolt
4	$\frac{3}{8}$ " Flange Nut

Parts Figure 8: Latch Assembly for Overlap Doors

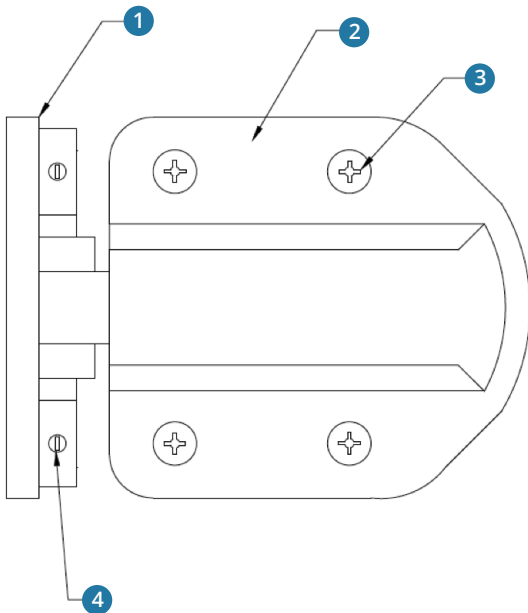

Part No	Description
1	Latch Strike
2	Latch Base
3	#14 x 1 $\frac{3}{4}$ " Phillips Head Screw
4	Bolt Lock

Parts Figure 9: Outside Release Assembly for Overlap Doors

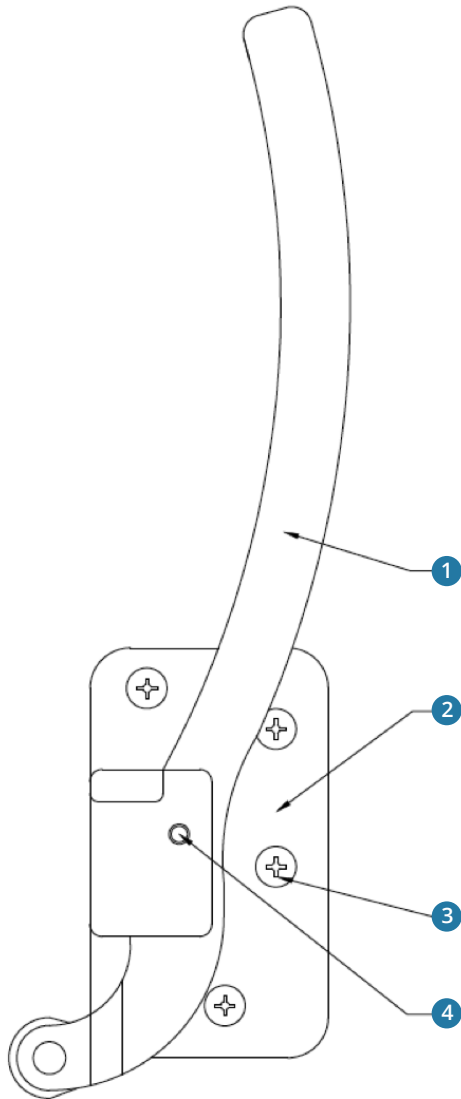

Part No	Description
1	Outside Release Handle
2	Outside Release Handle Bracket
3	#14 x 1¾" Phillips Head Screw
4	Outside Handle Pin

Parts Figure 10: Inside Release Assembly for Overlap Doors

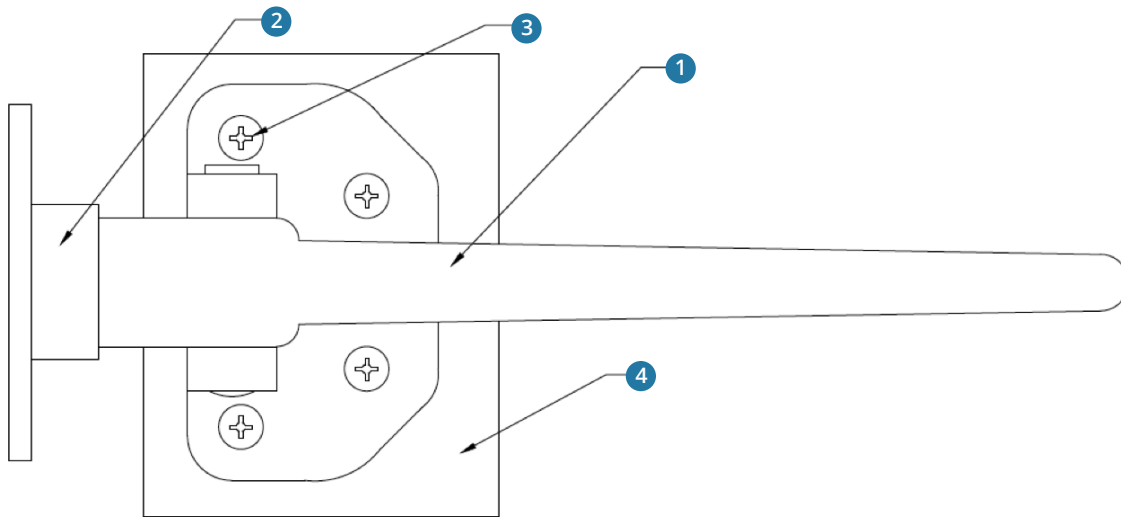

Part No	Description
1	Inside Release Handle
2	Inside Release Handle Bracket
3	#14 x 2" Phillips Head Screw
4	Plastic Block - Freezer Doors only



11502 Century Blvd,
Cincinnati, OH 45246

Main: 855.447.4957

Email: Hercules@senneca.com

www.herculesdoors.com

INFITOVER - MAN-1122