

Installation Instructions 1950



Safety and Warnings

FOR YOUR SAFETY

Read and observe all **CAUTIONS** and **WARNINGS** shown throughout these instructions.

While performing installations described; gloves, safety glasses or goggles should be worn.



Prepare Electrical Wiring

Electrical requirements:

This appliance must be supplied with 120V, 60 Hz, and connected to an individual and properly grounded branch circuit, protected by a 15 or 20 ampere circuit breaker or time delay fuse.



BEFORE YOU BEGIN

Read instructions completely and carefully.



For use inside a commercial refrigeration case with packaged foods only.

1950 Window Installation Instructions

1. Window should be handled with appropriate window moving tools such as suction cup that are rated to 1000 #.
2. Check net opening before installation. Net opening size for both height and width must be larger than the welded aluminum frames by approximately 1/8". The wall thickness plus all other wall items such as drywall, tile, etc. must match the work order for window thickness ordered.
3. Position the front (Ambient or Customer side) frame first. Drill pilot holes for the installation screws, going through both the aluminum frame and into the side of the walk-in box. These fastener heads will not be visible to customers after installation.
4. Use food grade silicone to seal customer side extrusion to the wall. (See below.)
5. Locate the sealed glass unit into the wall so it is flush with the customer side extrusion. Note that shims can be used to keep this centered in the opening.
6. Once centered, fill the gap between the wall and the sealed glass unit with expandable urethane foam.
7. Install the refrigerated zone side of the frame using silicone and fasteners through the decorator flange.
8. For heated glass applications, the glass pack is heated.

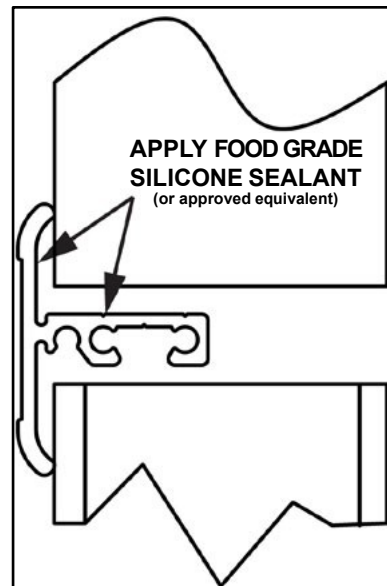
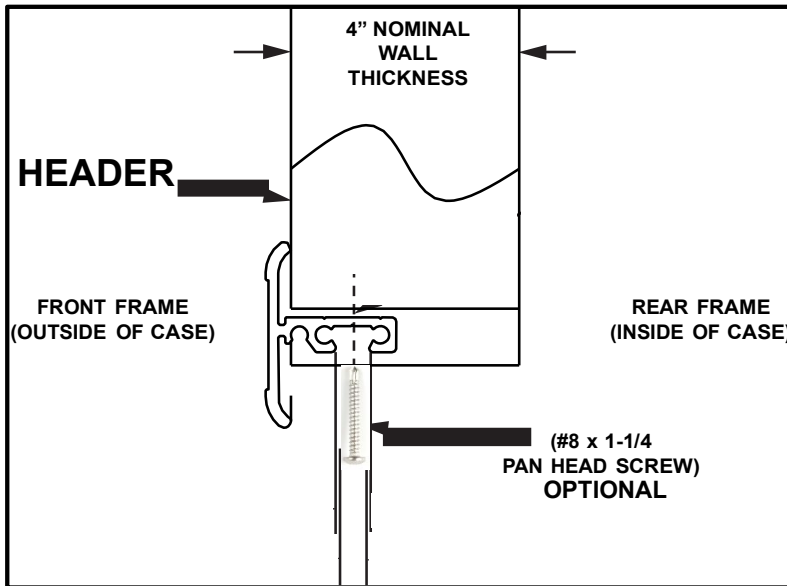
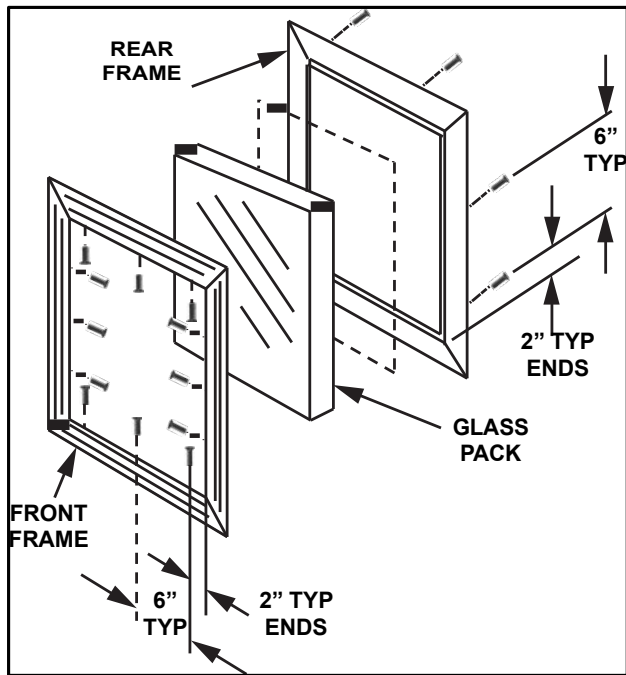

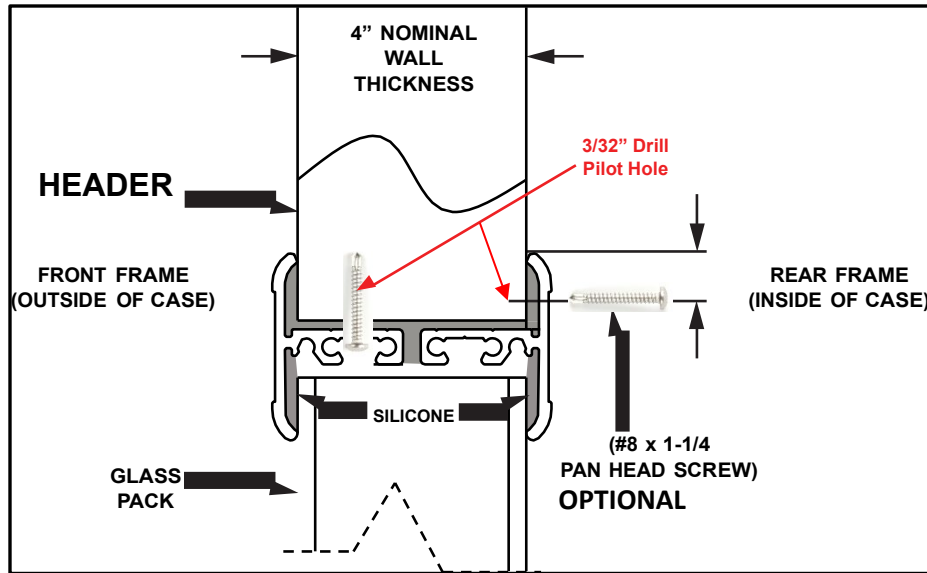

Revision History

<u>Rev.</u>	<u>Description</u>	<u>Date</u>	<u>Orig.</u>	<u>Inc.</u>	<u>Chk.</u>
A	Production release	12/12/25	HT	HT	