

INSTALLATION & SERVICE MANUAL



THERMOSEAL®

INSTALLATION & SERVICE MANUAL



Introduction

This manual provides information required to perform installation, repairs, and required maintenance to the Thermoseal Frames and Doors. This manual is intended as a written guide for personnel who are properly trained and qualified to safely use a variety of different equipment and tools required during the installation, repairs, and performing maintenance of the Thermoseal Frames and Doors.

All personnel/contractors assigned to install Thermoseal Frames and/or Doors must read this manual in its entirety as one of the steps in being certified to install and work on Thermoseal doors. Failure to read and thoroughly understand the material contained in this manual may ultimately result in damage to the equipment, and injury to personnel, and could void the warranty.

The components and systems described in this manual may be operated only by personnel qualified for the specific task by the relevant documentation, warning notices, and safety instructions. Qualified personnel are those who, based on their training and experience can identify risks and avoid potential hazards when working with these types of components and systems.

Proper use of Thermoseal Products

Thermoseal products may only be used for the applications described in the catalog and the relevant technical documentation. If products and components from other manufacturers are used, these must be recommended or approved by Thermoseal. Proper transport, storage, installation, assembly, commissioning, operation, and maintenance are required to ensure that the products operate safely and without any problems. The permissible ambient conditions must be complied with.

Safety and Warnings



BEFORE YOU BEGIN

Read instructions completely and carefully.

WARNING: TO REDUCE THE RISK OF FIRE, ELECTRICAL SHOCK OR INJURY, OBSERVE THE FOLLOWING:

- 1) Use this unit in the manner intended by the manufacturer.
- 2) Before servicing or altering, switch power off.



For use inside a commercial refrigeration case with packaged foods only.

FOR YOUR SAFETY

Read and observe all CAUTIONS and WARNINGS

shown throughout these instructions. While performing installations described; gloves, safety glasses or goggles should be worn.



PREPARE ELECTRICAL WIRING

Electrical requirements

This appliance must be supplied with 120V, 60 Hz, and connected to an individual and properly grounded branch circuit, protected by a 15 or 20 ampere circuit breaker or time delay fuse.

Grounding Instructions – Cable Direct







This lighting system must be connected to a grounded metal, permanent wiring system, or an equipment grounding connector must be run with the system conductors and be connected to the equipment grounding terminal or lead on the lighting fixture.

PROTECTIVE GEAR NOTICE

	<p><i>Protective Eyewear– Potential risk of eye injuries, protective eyewear required when performing this, and any other associated tasks.</i></p>
	<p><i>Protective Gloves– Potential risk of injury to your hands, protective gloves required when performing this, and any other associated tasks.</i></p>
	<p><i>Footwear Protective – Potential risk of injury to your feet, wearing protective footwear is required when performing this and any other associated tasks.</i></p>

SERIAL PLATES

To assist our customer with technical information or ordering spare parts, frames and doors have a serial plate which informs about model number, part number, manufacture date, work number and electric ratings.

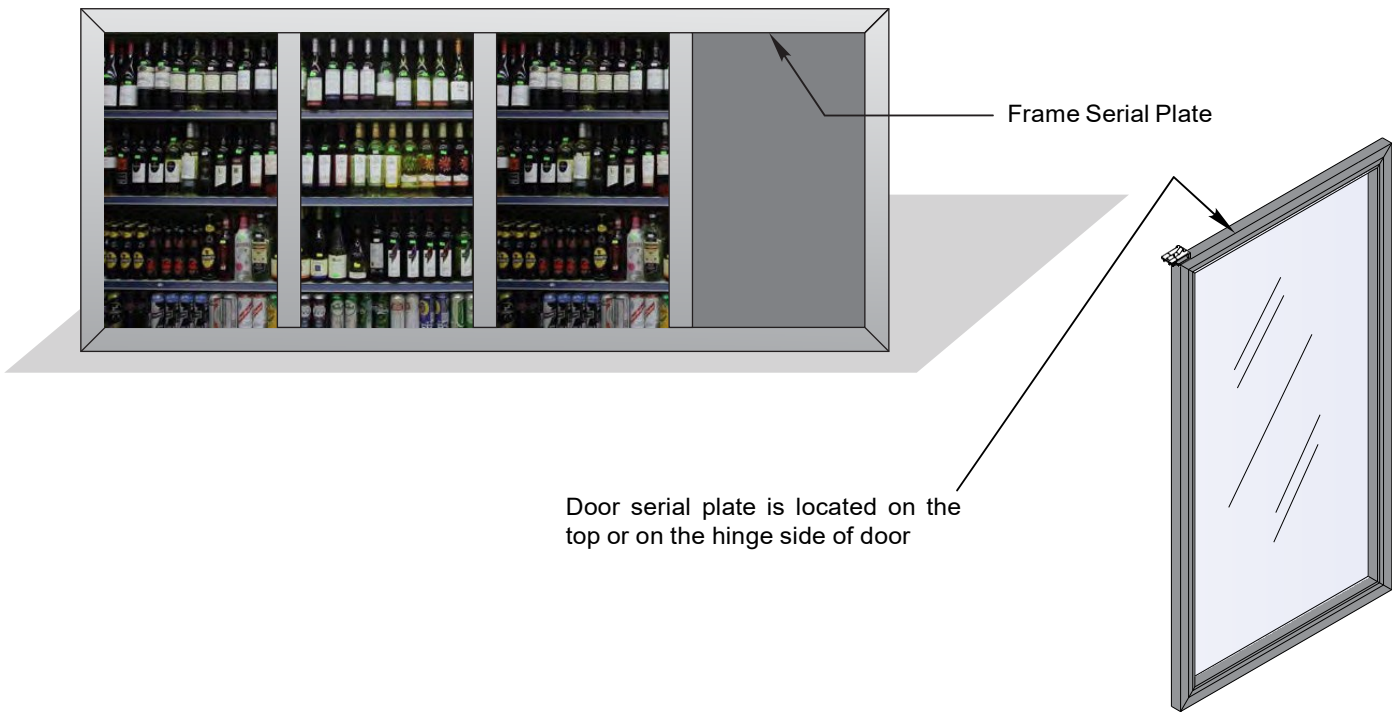

WO#: D59589-9	Model - SN	ELECTRICAL VAC: 115 / HZ: 60 Ø: 1							
CPart#: PRD-1134	TC-MT-2980-3D	DOOR A: _____ OHM ACT: _____							
Date Of Mfg: 7/13/2023	Actual Size: 88.19 X 79	FRAME A: 0.63 OHM ACT: _____							
Schd-Unit #: 41315-1	Door Swing: LH	LIGHT A: 0.47	Conforms to NSF STD 2 & UL STD 471 Certified to CSA STD C22.2 # 120						

Electrical safety, and sanitation certified by an approved third party certification agency.



WO#: D57600-1	Model - SN	ELECTRICAL VAC: 115 / HZ: 60 Ø: 1							
CPart#: PRD-1115G	1400T-MT-2774-DR	DOOR A: 0.07 OHM ACT: _____							
Date Of Mfg: 7/12/2023	Actual Size: 26.38 X 73.06	FRAME A: _____ OHM ACT: _____							
Schd-Unit #: 41224-68	Door Swing: RH	LIGHT A: _____	Conforms to NSF STD 2 & UL STD 471 Certified to CSA STD C22.2 # 120						

FRAME INSTALLATION

PROTECTIVE GEAR NOTICE	
	<i>Protective Eyewear– Potential risk of eye injuries, protective eyewear required when performing this, and any other associated tasks.</i>
	<i>Protective Gloves– Potential risk of injury to your hands, protective gloves required when performing this, and any other associated tasks.</i>
	<i>Footwear Protective – Potential risk of injury to your feet, wearing protective footwear is required when performing this and any other associated tasks.</i>

Installing the Frame Assembly into the Net Opening

Read instructions completely before installing frame.

1. The clearance between the frame sill and the bottom of the case or floor is mandated by local building codes.
2. The sill of the net opening must be a minimum of two (2) inches in height.
3. The sill must also be completely level.

Before installing the frame, confirm that the size of the net opening accommodates the finished frame. If the tolerances are too tight, the net opening will have to be enlarged.

Measure the size of the net opening and the size of the finished frame.

1. Subtract the frame height measurement from the net opening's height measurement.
2. Subtract the frame width measurement, from the net opening's width measurement.
3. Divide each number in half. This is the amount of gap that will occur between the frame and the net opening.

If there is a gap greater than 1/16" of an inch between the frame and the net-opening, then shim(as required) the gap.

SHIMMING(as required)

1. Acquire sturdy, penetrable material, such as plywood. The thickness of the material should be wedge shaped or slightly less than the gap to be filled.
2. Measure the length of the gap (height or width of frame) and cut the shim material to 1/16" of an inch less than the measure length.
3. Install the shim using the same type of mounting hardware that will be used to install the frame. Be certain that the shim installation hardware will not interfere with the frame installation hardware.
4. If necessary, cut a second shim to the same length and install it in the opposite side of the net opening.
5. If the adjacent sides of the net opening need to be shimmed, repeat the previous steps, matching the shim length of the frame sides of the net opening (less 1/16" of an inch).

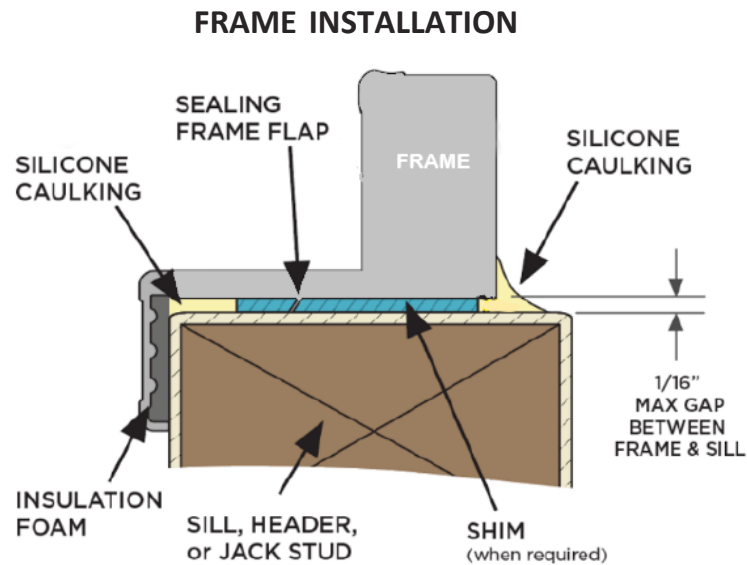

Confirm the net-opening conforms to openings listed in price book or original order.

- Insert the finished frame assembly into the net opening. If the fit is too tight, **DO NOT** force the frame.
 - Insert a mounting screw into a mounting hole in each corner of the frame and tighten each screw until it is approximately a quarter inch from flush.
 - Check and confirm that the frame is square.
 - Using a 25 foot measuring tape, measure diagonally from one corner to the opposite corner, noting the distance.
 - Measure the distance between the remaining two corners.
- Both measurements should be the same, within a 1/16" of an inch difference.
- Confirm that the frame and frame flanges are plumb to the surface of the wall around the net opening.
 - Place a level on the top flange of the header frame to check header level.
 - If the top of the frame (Header Frame) is sagging or bowing, correct as necessary.
 - When the frame is square and plumb, tighten all mounting screws securely until each is flush to the surface of the frame.

WARNING	
	<p><i>Warning: DO NOT over tighten screws onto the frame, as this may cause bowing, sagging, or the frame to become out of square. This will cause installation issues with Door's proper function. Adjusted the frame as needed to ensure it is square and free of bowing and sags.</i></p>

FRAME INSTALLATION

Check entire frame to ensure installation is correct.

Seal the gap between the frame and the surrounding wall, inside the case, cooler or freezer using a caulking gun and NSF approved food grade silicone sealant (RTV-108). Not following these procedures can void Thermoseal Service & Warranty on condensation and ice build-up issues. Once Silicone Sealant is cured double-check for any remaining gaps that require more sealant.

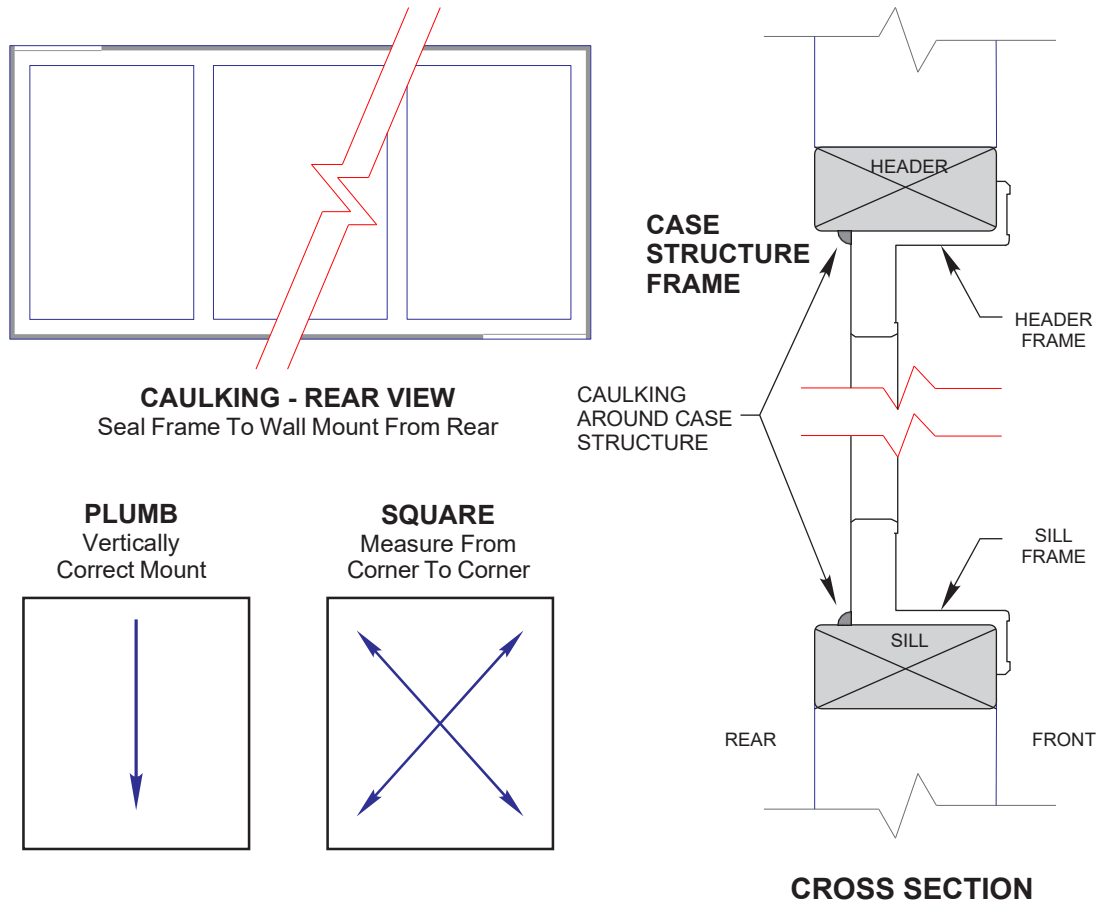

WARNING	
	<p><i>Warning: Use only food-grade silicone sealant (add caulking for larger gaps) to seal the gap between the frame and the surrounding wall, inside the case, cooler or freezer. Not following these procedures can void Thermoseal's Service & Warranty on condensation and ice build-up issues.</i></p>



Frame Electrical Wiring Connections

The individual wires that extend from the flexible conduit on top of the frame, provide electrical power to various frame and door functions. Refer to the wiring ID tags attached to the wire leads.

Using NEC approved wire connectors, these wires should be grouped by the Hot wires (or Circuit wires), the Neutral wires and the Ground wire for connection to either the facility or the case power.

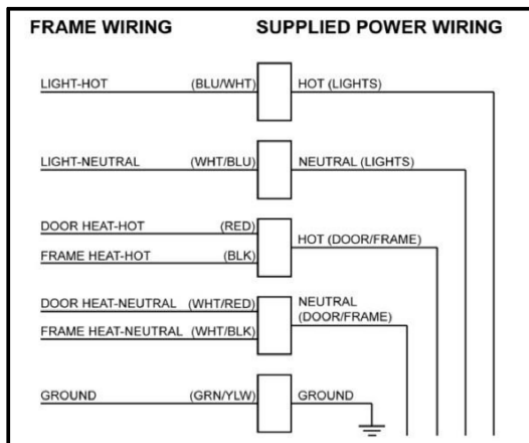
- Blue/White wire connects to the supplied Hot(or light Circuit Wire)
- White/Blue wire connects to the supplied Light neutral wire.
- Red and Black wires connect to the supplied Hot(or Door/Frame Heater Circuit Wire).
- White/Red and White/Black wires connect to supplied neutral wire for the Door/Frame circuit.
- Green/Yellow wire connects to the supplied ground wire.



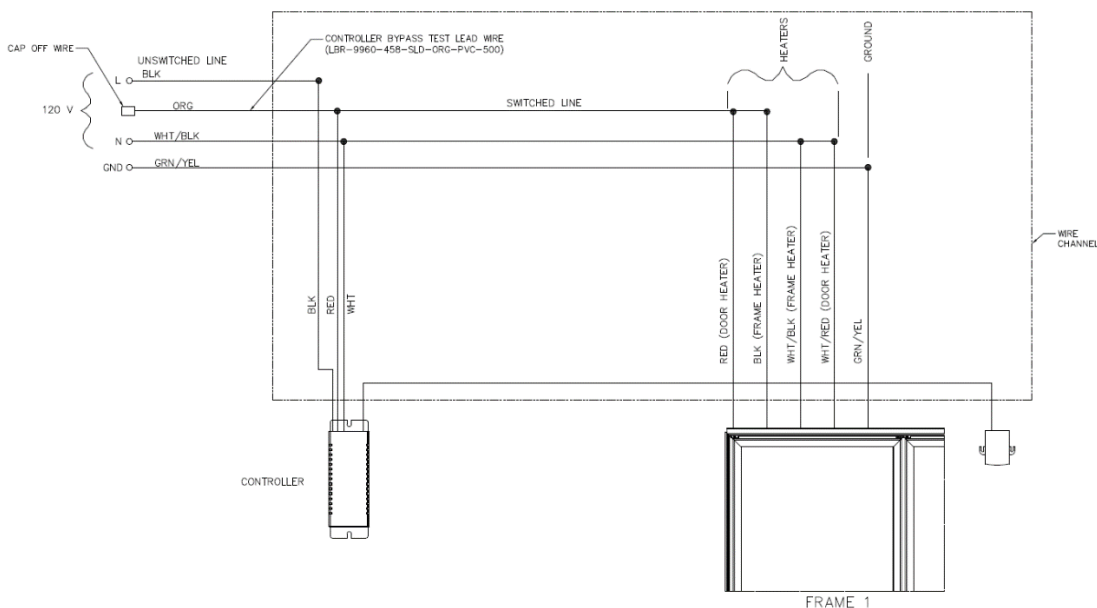

WARNING	
	Stop: Wiring for lights should have a separate circuit from the door/frame heater wiring circuit.
WARNING	
	Warning – To reduce the risk of fire, electrical shock or injury observe the following: <ul style="list-style-type: none"> - Use this unit in the manner intended by the manufacturer. - Turn the power off before removing the existing lighting system and follow appropriate lockout/tag-out safety procedures
WARNING	
	Risk of Electrical Shock– Potential risk of Electrical Shock; pay close attention to instructions when performing this and any other associated tasks.

Wiring Schematic Anti-Sweat Controller



Continuous Lineup Frame Installation

PROTECTIVE GEAR NOTICE	
	<i>Protective Eyewear– Potential risk of eye injuries, protective eyewear required when performing this, and any other associated tasks.</i>
	<i>Protective Gloves– Potential risk of injury to your hands, protective gloves required when performing this, and any other associated tasks.</i>
	<i>Footwear Protective – Potential risk of injury to your feet, wearing protective footwear is required when performing this and any other associated tasks.</i>

Two (2) or more Frame Sections Line-up

The following instructions are for installations that required two (2) frame sections or more:

1. To begin, set the first frame (ensure that the first frame has a full flange on the right side and continuous flange on the left side) against the far-right side of the net/opening/case opening and install according to instructions previously noted in this section ensuring to square, plumb, secure, and seal the first frame (shim if needed). To continue installing the next frame you will need to install the T-Trim between frames.
2. Ensure the first frame is installed correctly, then set the second frame/next frame into the net opening/case opening (ensure that the second frame has a full flange on the left side and a continuous flange on the right side). Slide the second frame/next frame to the far left of the net opening/case opening and slide the frame inside the opening. Ensure to square, plumb, secure, and seal the frame (shim if needed). Use instructions given on previous pages.
3. After installing the second frame/next frame insert a T-Trim between the first, second and more frames.
4. Once T-Trim is in place, insert binding bolts (sex bolts) through the right side of the first frame, and into the left side of the second frame/next frame. Tighten until frames are pulled together. Refer to Figures for T-Trim Installation below.

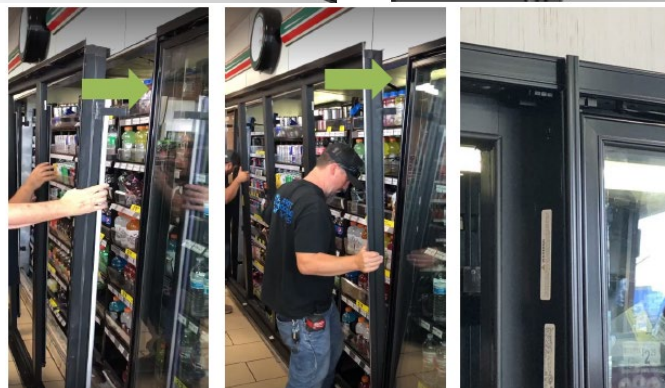
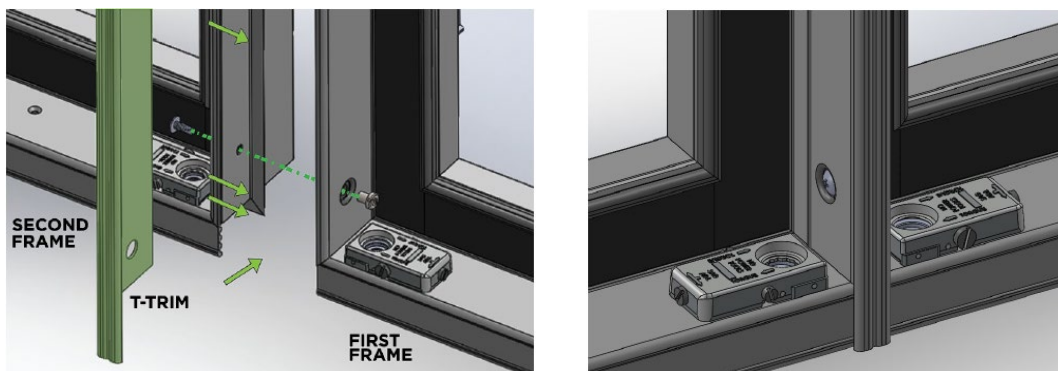

Continuous frame sections configuration layouts

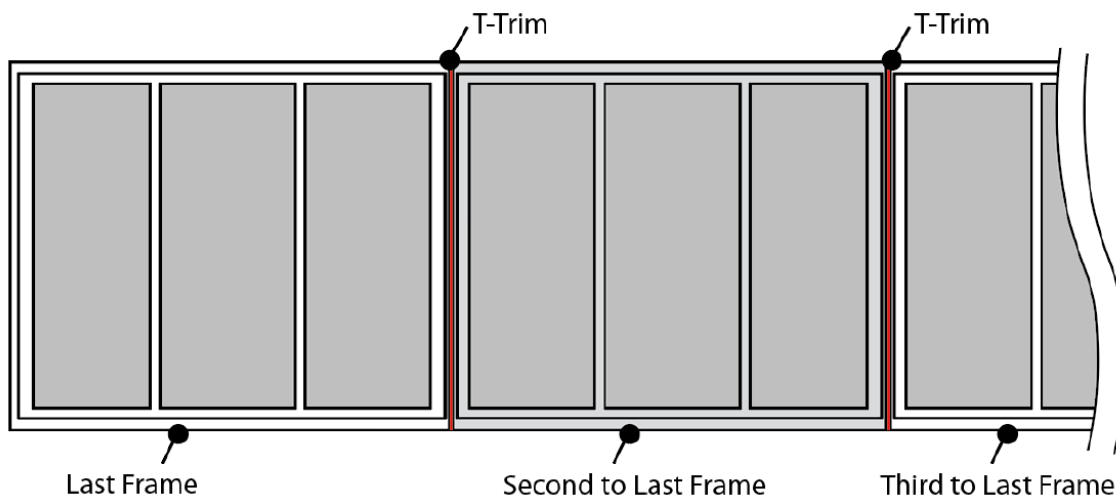
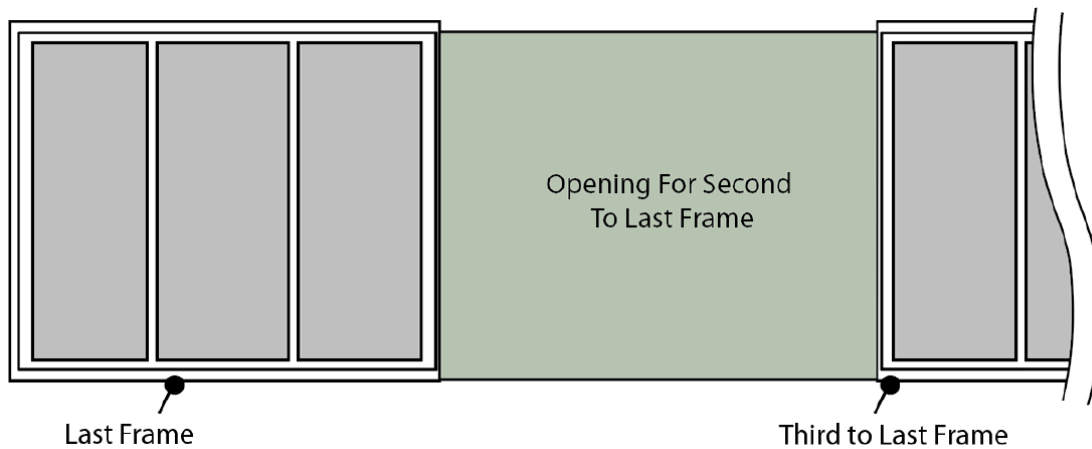
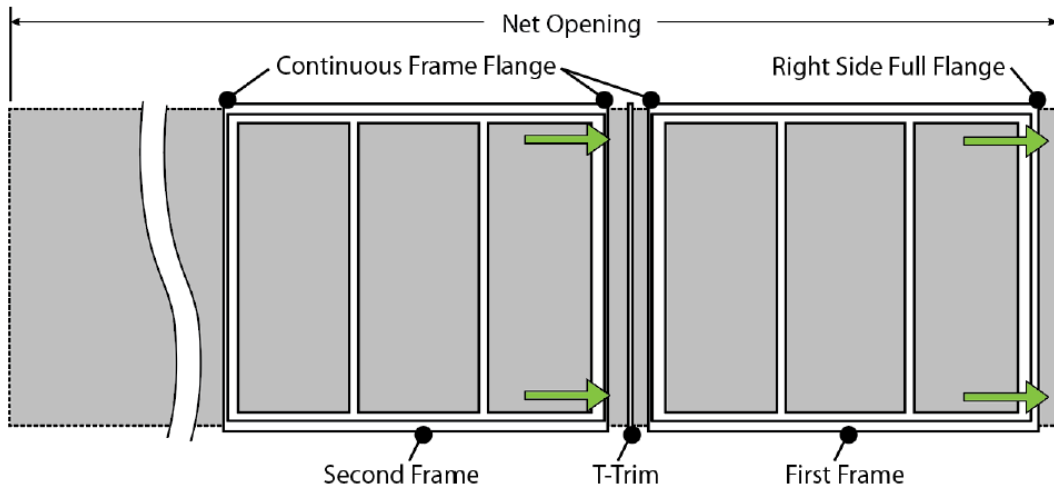

- Once all frame and T-Trims have been installed, seal the entire line-up from inside of the case, caulking all four sides of the frame, in between the frame and net opening, and in any gaps left on the back end of the frames caused using the T-Trim(s) that were installed.

DOOR INSTALLATION

1. Handling each door carefully, install them into the frame, one at a time by inserting the torque rod-end into the cavity of the torque adjuster.
2. Tilt the top of the door up and toward the frame, inserting the hinge pin into the GIB (Guide In Bracket), located in the top of the door frame making sure that the spring clip engages into the upper frame rail.

Note: Make sure the clip fully engages into the frame. If the clip is not installed correctly the door could fall out.

3. Insert the hold-open bolt through the elongated hold-open slot and into the frame mounting hole. Tighten with a phillips-head screwdriver.
4. Adjust the door swing and door squareness by adjusting the door closer. (see Torque and Sag Adjustment below)

WARNING	
	<p><i>WARNING: DO NOT use power tools to install and secure the hold-open screw.</i></p>

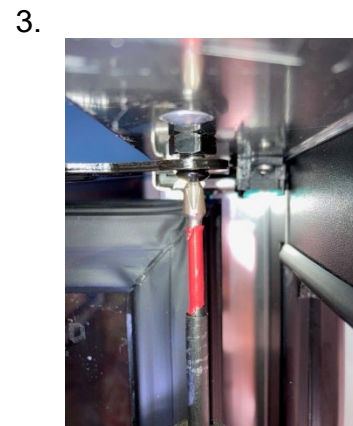
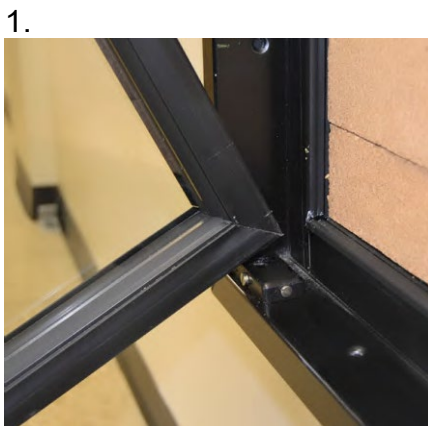

Torque and Sag Adjustment

1. The torque adjuster regulates the door squareness and tension of the door swing.
2. Use the flathead screwdriver; adjust the torque rod tension by turning the outside screw on the torque adjuster.
 - Turn counter-clockwise to increase tension.
 - Turn clock-wise to decrease the tension.
3. Adjust the door sag to square it in the frame by turning the screw that is marked SAG ADJ. (sag adjustment), on the end of the torque adjuster, until the door slowly closes itself.
4. Turn the screw clockwise to lower the handle side of the door.
5. Turn the screw counter-clockwise to raise the door's handle side.

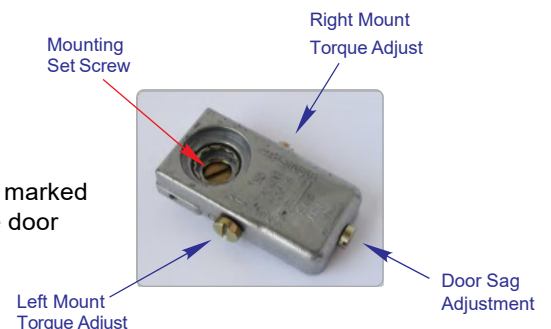

WARNING	
	<p><i>Warning: Exercise caution when handling the door and DO NOT use power tools when adjusting the Torque Master™.</i></p>

TOP HINGE SAFETY

Explanation of Hinge Pin Engagement

During door installation, the connector body of the hinge pin assembly is inserted into the single or double GIB (Guide In Bracket) on the frame. The GIB provides the proper alignment for the electrical pins on the hinge pin assembly to engage the hinge pin receptacle. The lock spring located on top of the hinge pin assembly engaged into the upper frame rail once the hinge pin assembly has fully engaged the receptacle locking it securely in place. Once the hinge pin assembly is fully engaged the door can only be removed by inserting a pair of needle nose pliers into the square hole in the lock spring allowing the spring to be compressed, disengaging it from the upper frame rail and allowing it to be pulled free from the receptacle.



DOOR REMOVAL

PROTECTIVE GEAR NOTICE	
	<i>Protective Eyewear– Potential risk of eye injuries, protective eyewear required when performing this, and any other associated tasks.</i>
	<i>Protective Gloves– Potential risk of injury to your hands, protective gloves required when performing this, and any other associated tasks.</i>
	<i>Footwear Protective – Potential risk of injury to your feet, wearing protective footwear is required when performing this and any other associated tasks.</i>

1. Using a flat-head screwdriver, turn the adjustment screw on the front of the torque adjuster clockwise until the door no longer self-closes.



2. Open the door to access the hold-open device and remove the mounting bolt from the frame using a Phillips-head screwdriver.

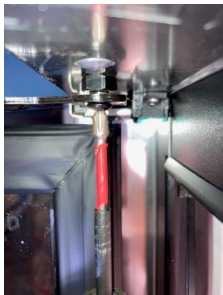

3. With the door in a nearly closed position, insert the top half of the needle-nose pliers into the grip hole in the hinge pin spring clip and the bottom half of the pliers beneath the hinge pin shroud.





4. Squeeze the pliers to pull down the spring clip, while simultaneously pulling the top of the door away from the frame and pull the top of the door out.



5. Lift and remove the door from the torque adjuster.



REVERSING THE DOOR SWING

PROTECTIVE GEAR NOTICE	
	<i>Protective Eyewear– Potential risk of eye injuries, protective eyewear required when performing this, and any other associated tasks.</i>
	<i>Protective Gloves– Potential risk of injury to your hands, protective gloves required when performing this, and any other associated tasks.</i>
	<i>Footwear Protective – Potential risk of injury to your feet, wearing protective footwear is required when performing this and any other associated tasks.</i>

1. Using a flat-head screwdriver, loosen the torque adjuster from its mount by turning the center mounting screw counter-clockwise less than one-half ($\frac{1}{2}$) of a turn.
2. Remove the torque adjuster, exposing the mounting hole in the bottom frame rail.
3. Locate the mounting hole at the opposite side of the door opening.
4. Using the flat-head screwdriver, carefully pry underneath the plug cap and remove it.
5. Place the torque adjuster on the newly opened mounting hole, aligning the flanged corners of the mounting tabs.
6. Insert the torque adjuster mounting tabs onto the mounting hole with the hollow end of the torque adjuster against the door frame.
7. Confirm that the mounting flanges on the bottom of the torque adjuster align with the corner mounting slots of the mounting hole in the frame.
8. Using a flat-head screwdriver, turn the torque adjuster mounting set-screw clockwise, for $\frac{1}{2}$ a turn, to tighten the mount and lock it in place. Confirm that the torque adjuster mounting is flush with the door frame.
9. Using a Phillips head screwdriver, loosen and remove the hold-open bolt from the top frame rail.
10. Relocate and install the hold-open shoulder bolts into the opposite hold-open mount of the same door frame.
11. Ensure the power is OFF. Open the vertical side access to the hinge pin wire connections in the rail on the hinge side of the door assembly.
12. Disconnect the Hot, Neutral and Ground wires of the hinge pin from the heater wire circuit and the ground terminal.
13. Completely remove the hinge pin assembly from the top door rail.
14. Using a plastic mallet and a flat-head screwdriver, remove the torque rod from the bottom of the door assembly.
15. Swap placement of the Hinge Pin and Torque Rod to the other's original mounting hole in the door assembly hinge side rail.
16. Reinstall the hinge pin and the torque rod completely into the ends of the door assembly hinge rail.
17. If necessary, lightly tap on the torque rod with a plastic or rubber mallet until fully seated into the bottom of the door.
18. Reconnect the hinge in wires and confirm that all connections are secure.
19. Check and confirm torque rod and hinge pin are correctly and completely installed.
20. Reinstall the door into the frame.

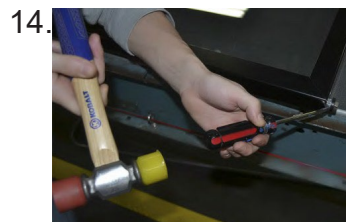
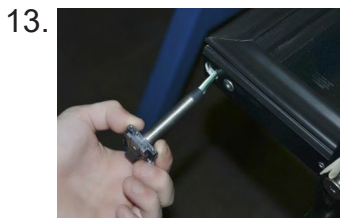
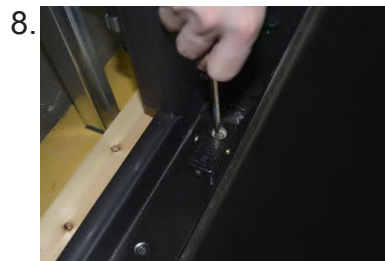
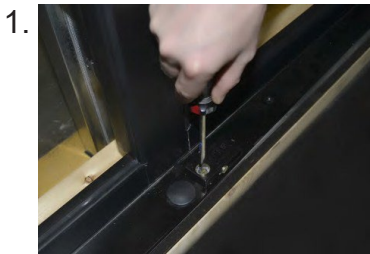

REPLACING THE DOOR HEATER

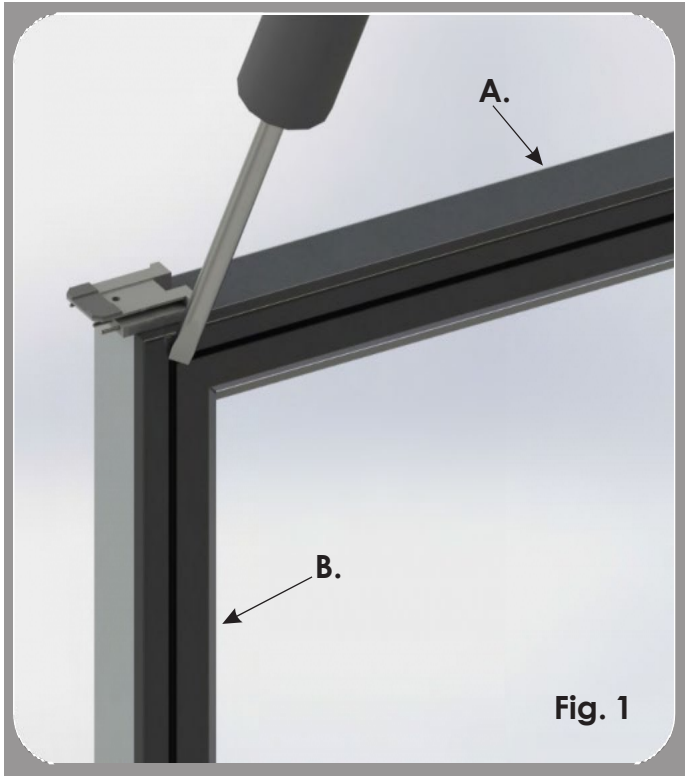

Disconnect frame from power source. Remove the door. Remove the magnetic gasket (A) by starting on the upper corner and work your way down. Carefully remove plastic (B) cover with a screwdriver, starting at the upper corner (Fig. 1). If plastic cover becomes damaged it has to be replaced.

Refer to Fig. 2 for heater wire location. Remove the heater from the door rail, and cut the leads at the hinge pin power connection.

Starting at the upper hinge side corner, run the new heater around the door, pressing the heater into the aluminum channel the old one was removed from.

Connect the new heater to the hinge pin leads as shown in Fig. 3.

Connect the heated glass wires connectors using the wire splitters as shown on Fig 4 into the hinge pin leads.

Carefully replace the plastic back molding. Reinstall the gasket (see gasket replacement instructions). Reinstall the door (see door installation instructions).

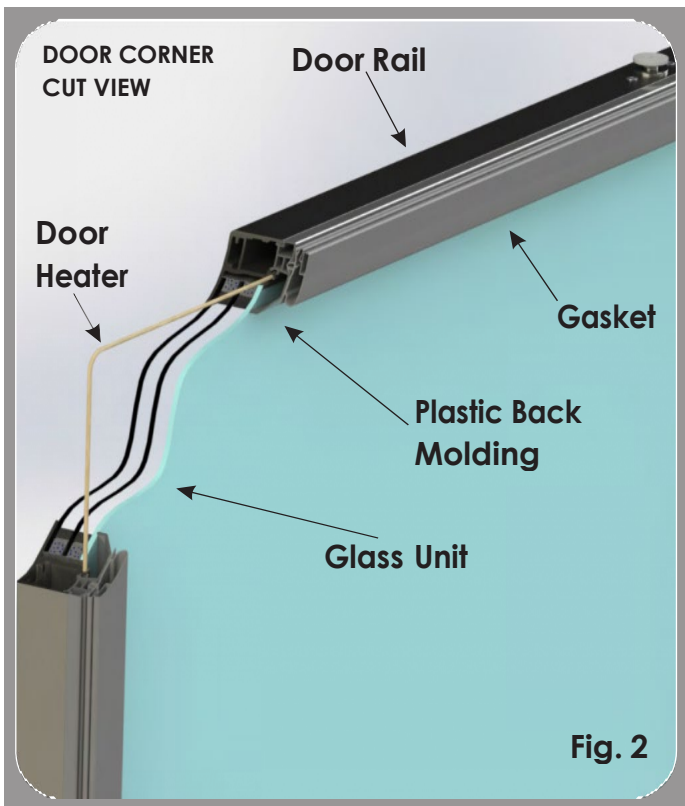

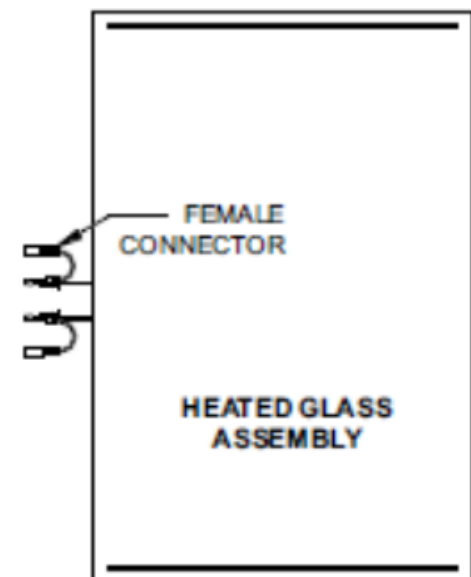
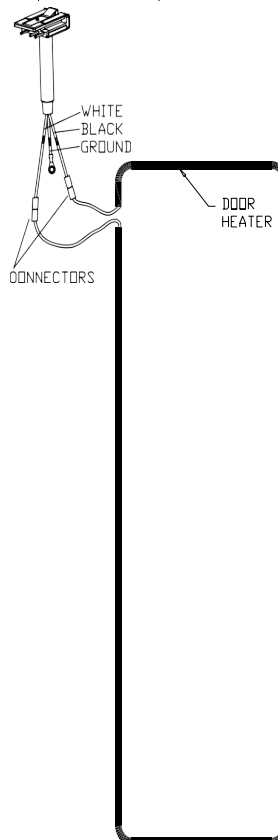

WARNING	
	<p><i>Warning –Make sure to turn off the Light switch on the Frame Mullion (right most) before starting the replacement process.</i></p>



Note: This heated glass configuration may not be on every door.

INSTALLATION & SERVICE MANUAL

REMOVING & REPLACING THE DOOR CLOSER

PROTECTIVE GEAR NOTICE	
	<i>Protective Eyewear– Potential risk of eye injuries, protective eyewear required when performing this, and any other associated tasks.</i>
	<i>Protective Gloves– Potential risk of injury to your hands, protective gloves required when performing this, and any other associated tasks.</i>
	<i>Footwear Protective – Potential risk of injury to your feet, wearing protective footwear is required when performing this and any other associated tasks.</i>

- Carefully place a flathead screwdriver between the door rail and the washer beneath the torque rod. (A)
- Dislodge the torque rod from the door by pushing on the torque rod or tap it loose using a plastic or rubber mallet. (B)
- Once dislodged pull the torque rod completely out of the door.
- Reinstall a new torque rod by inserting it into the same hole fully seating it with a plastic or rubber mallet. (C)

WARNING	
	<i>Warning: DO NOT use a steel-headed hammer. Use caution when striking any tool with another tool. DO NOT use excessive force when striking the screwdriver and potentially damaging the door.</i>

A.



B.

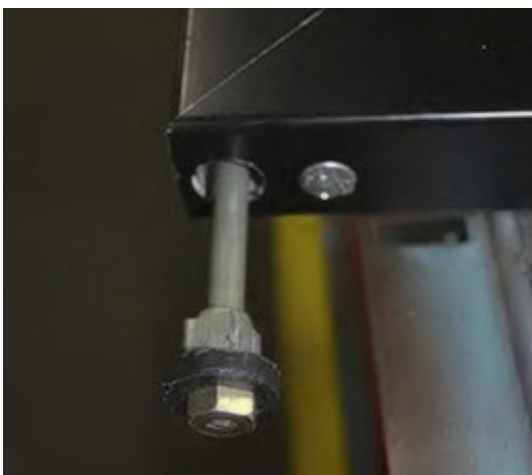

C.



GASKET REMOVAL & INSTALLATION

PROTECTIVE GEAR NOTICE	
	<i>Protective Eyewear— Potential risk of eye injuries, protective eyewear required when performing this, and any other associated tasks.</i>
	<i>Protective Gloves— Potential risk of injury to your hands, protective gloves required when performing this, and any other associated tasks.</i>
	<i>Footwear Protective – Potential risk of injury to your feet, wearing protective footwear is required when performing this and any other associated tasks.</i>

Gasket Removal

1. To remove, carefully pull the gasket straight out of the groove between the door rail and plastic cover starting at the top corner of the door.



2. Carefully pull the gasket out and downward of the groove in the plastic rail covers.



3. Continue to pull the gasket from the plastic rails gently around the entire perimeter.

WARNING



Warning – Warning: The gasket is composed of soft materials with welded miter joints. Use extra care when manually extracting the gasket from the rail grooves to prevent damaging it as well as the plastic rail.

Gasket Installation

PROTECTIVE GEAR NOTICE	
	<i>Protective Eyewear– Potential risk of eye injuries, protective eyewear required when performing this, and any other associated tasks.</i>
	<i>Protective Gloves– Potential risk of injury to your hands, protective gloves required when performing this, and any other associated tasks.</i>
	<i>Footwear Protective – Potential risk of injury to your feet, wearing protective footwear is required when performing this and any other associated tasks.</i>

To install the gasket onto the door, follow the steps below:

1. Carefully align the two corners of the replacement gasket onto the top corners of the plastic cover, with the gasket arrow facing the door rail and cover.



2. With the corners aligned, press the arrows of the gasket into the gasket retainer groove and press firmly on the gasket until the gasket is seated into the groove and corners.





3. Continue to insert the gasket arrow into the groove around the perimeter of the door surface and work from center out to each corner by pressing the gasket firmly against the plastic cover, sliding from side to side, and applying full pressure against the gasket, forcing the gasket arrow into the groove in the plastic.

- When you get near the bottom of the door, carefully align the two bottom corners of the gasket onto the bottom corners of the plastic cover, with the gasket arrow facing the door rail and cover.





- Continue to insert the gasket arrow into the groove around the remaining perimeter of the door surface by pressing the gasket firmly against the plastic cover, sliding from side to side, and applying full pressure against the gasket, forcing the gasket arrow into the groove in the plastic.



WARNING	
	<p><i>Note: Pay careful attention that the arrows are firmly pressed into the grooves at the corners. A rubber mallet can be utilized if the arrows do not easily insert into the grooves.</i></p>
WARNING	
	<p><i>Note: If the gasket has any signs of deformation from the packaging it is acceptable to use a low heat blower to warm the gasket. This can be performed by blowing warm air on the gaskets in a sweeping motion to warm the gaskets between 80°F and 110°F so the gasket can reshape.</i></p>
WARNING	
	<p><i>Note: Make sure the gasket lay flat against the frame, specially at the hinge side, top and bottom corners, avoiding the gasket bending and bulging. This is particularly important during the first time the door closes.</i></p>

INSTALLATION & SERVICE MANUAL

Door Handle Replacement

PROTECTIVE GEAR NOTICE	
	<i>Protective Eyewear– Potential risk of eye injuries, protective eyewear required when performing this, and any other associated tasks.</i>
	<i>Protective Gloves– Potential risk of injury to your hands, protective gloves required when performing this, and any other associated tasks.</i>
	<i>Footwear Protective – Potential risk of injury to your feet, wearing protective footwear is required when performing this and any other associated tasks.</i>

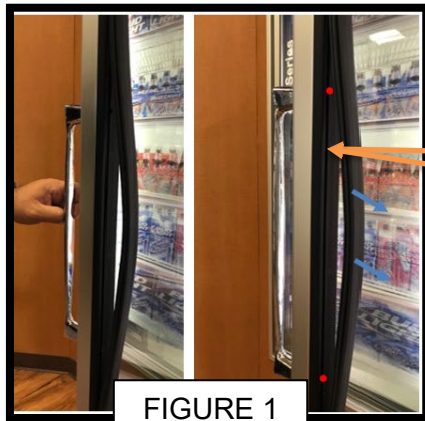

FIGURE 1

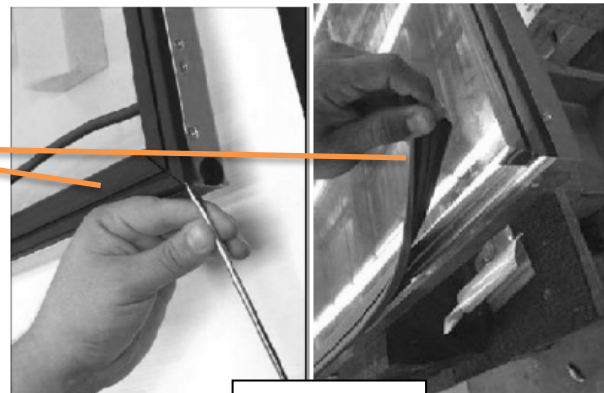



FIGURE 2

1. To remove the door handle you will need to access the screws on the back for the door rail located behind the door gasket and PVC backer plastic cover.
2. To locate screws, open the door enough to easily access the door gasket(FIGURE 1) and PVC backer plastic cover(FIGURE 2) located on the perimeter on the inside of the door rail. **Note:** Do not remove the entire door gasket from the door rail. Only the door handle rail side area that is required to replace the handle.
3. Proceed by gently and carefully pulling back the door gasket portion(FIGURE 1) along the area the top and bottom of opposing side of the handle are located, then proceed to remove the PVC backer plastic cover by inserting the end of a slot -head screwdriver in between two PVC backer plastic cover ends at the corner miter as shown on FIGURE 2. Carefully twist the screwdriver to loosen the corner of the plastic cover lip from the door rail. Continue to pry the PVC backer plastic cover from the handle side door rail until the entire end of the plastic rail is disengaged, as shown in FIGURE 2. Pull the PVC backer plastic cover up and out of the door rail grooves until the entire PVC backer plastic cover is removed from the handle side door rail.
4. To remove the two (2) handle screws, insert a 5/32-inch hex ball-driver t-handle or 5/32-inch Allen Wrench and turn counterclockwise to loosen the screws, ensure to hold the handle while loosening both screws to keep the handle from falling and to ease the removal of the handle. While loosening screws then ensure to push forward to keep the screws exposed on the front of the door. It's crucial that these screws are not removed and you will need to avoid them falling into the door rail.

WARNING	
	<i>Warning: Ensure that when loosening screws to remove the handle you continually push forward to keep the screws exposed on the front of the door. It's crucial that these screws are not removed and you will need to avoid them falling into the door rail.</i>

5. Once the two(2) screws are no longer engaged to the handle, pull the handle away and continue to push on on exposed screws.
6. With the two (2) screws exposed as shown figure below, locate the replacement handle, and align with the screws, ensure not to push screws in when doing this, and proceed by turning clockwise to secure screws into the handle. It is recommended to alternate between top and bottom screws when tightening for best results. It is also recommended to keep an eye on the handle alignment before completely tightening.



7. Once the handle is securely installed, proceed to re-install the PVC backer plastic cover, begin by aligning the PVC backer plastic cover evenly onto the handle side door rail. Insert the outer edge of the PVC backer plastic cover into the outside groove of one of the handle side door rail. Push the PVC backer plastic cover down and inward, toward the center of the door following the placement of the top and bottom PVC backer plastic cover as guidance. Slide along the entire length of the PVC backer plastic cover while firmly applying pressure against it. Continue applying pressure down along the length of the entire handle side door rail, inserting both the outside lip and the inside lip into the door rail grooves simultaneously.
8. Proceed to re-install the gasket by pressing the gasket dart firmly in place onto the PVC backer plastic cover of the handle side door rail.

REPLACING A FRAME HEATER

WARNING	
	<p><i>Warning –Make sure to turn off the Light switch on the Frame Mullion (right most) before starting the replacement process.</i></p>

Bottom, Mullion and Full Perimeter Fiberglass Heater Wire Replacement

If the heater wire requires servicing or replacement, perform the following tasks:

1. The frame power must be turned off prior to removing any sealing plates. This is all power. Frame heaters, door heaters, and lights.
2. Remove the appropriate EZ strip(s) to gain access to the heater wire(s).
3. With the contact plate(s) removed from the frame mullion and frame rails, locate the appropriate heater wire in the frame.
4. Disconnect the heater wire assembly from the Wago connectors.
5. Carefully dislodge the heater wire from the groove mounts along the frame rails.
6. Lay the replacement wire out in a fashion that will avoid knots and tangling during re-installation into the frame.
7. Using a screwdriver handle or a putty knife, insert the entire replacement heater wire into the groove inside the frame and arrange the wire assembly to the same configuration that it had prior to disassembly.
8. Install the wire ends from the replacement heater wire in each Wago removed in step 3.
9. Replace the contact plate(s) in step 2.
10. Replace the EZ strip(s) removed in step 1.

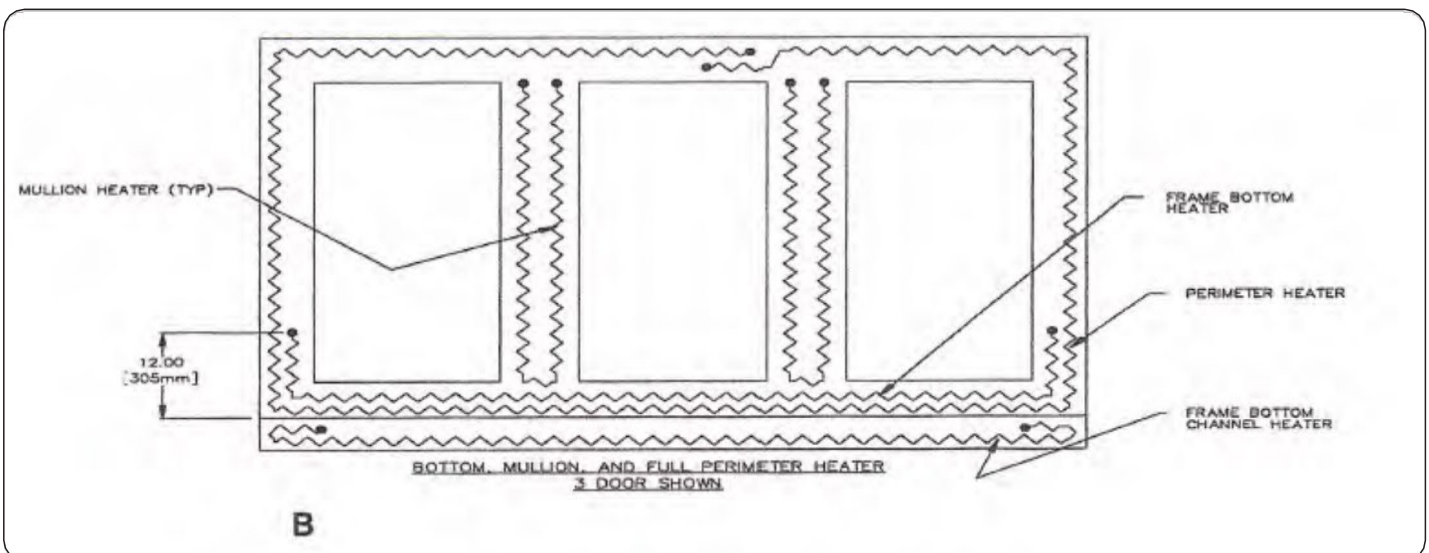
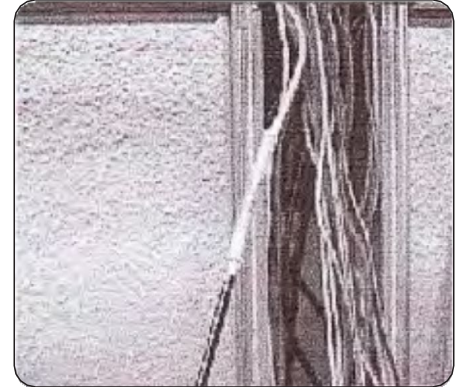

Removing & Replacing the Hold-Open Assembly

PROTECTIVE GEAR NOTICE	
	<i>Protective Eyewear— Potential risk of eye injuries, protective eyewear required when performing this, and any other associated tasks.</i>
	<i>Protective Gloves— Potential risk of injury to your hands, protective gloves required when performing this, and any other associated tasks.</i>
	<i>Footwear Protective – Potential risk of injury to your feet, wearing protective footwear is required when performing this and any other associated tasks.</i>

You must remove the door from the frame and place the door on a steady flat surface table to remove and replace the hold-open assembly.

Once the door is safely on a secure working surface use the following instructions to remove and replace the hold-open assembly.

Removing the Hold-Open Assembly

1. Remove screws from the hold-open standoffs, which are located on the door rail and frame. Refer Figure below.
2. Remove the hold open, standoffs, and discard them.
3. When replacing the hold open arm, reverse Step 1 by inserting the screw through the mounting hole in the Arm and tightening it into the frame mounting hole using the #2 Philips head screwdriver. Refer Figure below.



Replacing the Hold-Open Assembly

1. Insert the pivot standoff into the door.
2. Add Loctite #271 to threads. Torque to 100 in/lb
3. Place the pivot hole of the new hold open over the pivot standoff that is closest to the hinge pin.
4. Retain with a new truss head screw and torque to 16 in/lb (approximately #2 clutch setting on a professional Screw gun).
5. Remove the vinyl cap from the detent bolt.
6. Insert the bolt up thru the hold open slot and then thru the detent spacer (flat side against frame).
7. Add Loctite #271 to threads. Use a 7/16 hex wrench and torque into the frame to 100 in/lb.
8. Add a small amount of grease to the detent surface.
9. Ensure the truss head screw is seated on the end of the standoff and not the hold open.

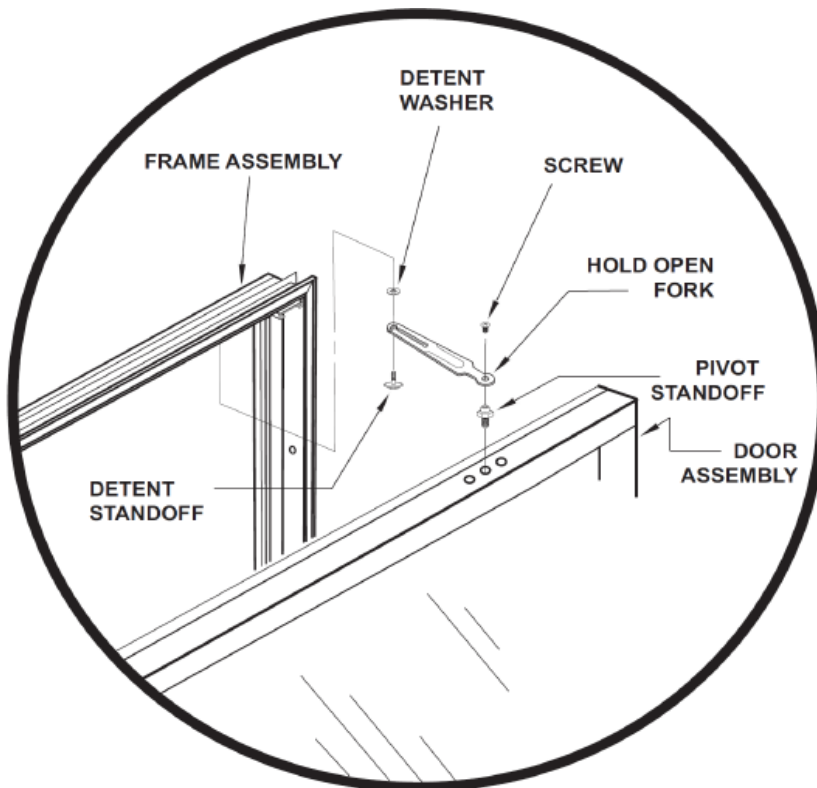

Removing & Replacing the Hinge Pin

PROTECTIVE GEAR NOTICE	
	<i>Protective Eyewear– Potential risk of eye injuries, protective eyewear required when performing this, and any other associated tasks.</i>
	<i>Protective Gloves– Potential risk of injury to your hands, protective gloves required when performing this, and any other associated tasks.</i>
	<i>Footwear Protective – Potential risk of injury to your feet, wearing protective footwear is required when performing this and any other associated tasks.</i>

1. With the access cover removed, pull the hinge pin wires out and separate all three wires (Hot, Neutral, and Ground) from the door wire harness by carefully pulling the terminals apart.

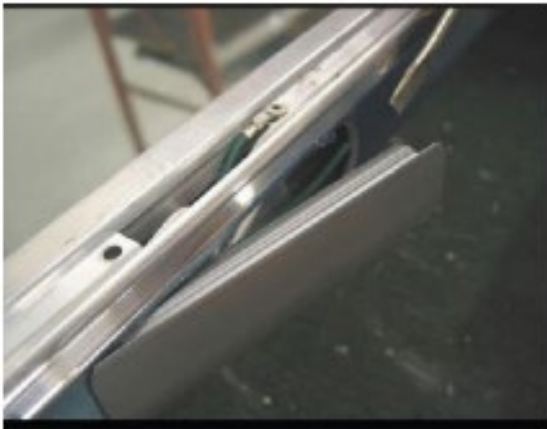

2. Using a flat-head screwdriver, pry the hinge pin loose from the mount in the top door frame rail.



3. Pull the hinge pin out of the door frame until the pin and the wires are completely removed.

4. Upon replacing the hinge pin, insert all three wires into the hinge pin hole in the door rail.

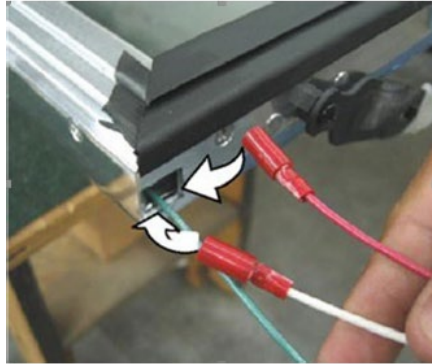

5. Thread the wires through the rail to the access opening.
6. Connect the hinge pin wires to the terminal door wires.
7. Insert the remainder of the hinge pin into the top door frame mounting hole until the hinge pin fully seated.
8. Harness wires together and insert the harness into the door rail access hole and install the access cover.
9. Ensure to apply high viscosity dielectric grease to the hinge pin receptacle. For doors in harsh ambient conditions, it is recommended to use a minimum of 3 grams of dielectric grease to fill the holes in the hinge pin receptacle socket as shown below.



10. Once dielectric grease is applied correctly, Proceed to re-install the door per instructions in “Door installation”(see page 11).

INSTALLATION & SERVICE MANUAL

EXPLODED VIEW - DOOR

Exploded view – Quick Load Door

- 1) Corner Block
- 2) Door Rail
- 3) Heater Wire
- 4) Insulated Glass Unit
- 5) Plastic Back Molding
- 6) Hinge Pin
- 7) Cable Bushing
- 8) Door Closer
- 9) Access Cover Cap
- 10) Handle
- 11) Hold Open Arm
- 12) Spacer
- 13) Shoulder Screw
- 14) Backer Plate
- 15) Gasket

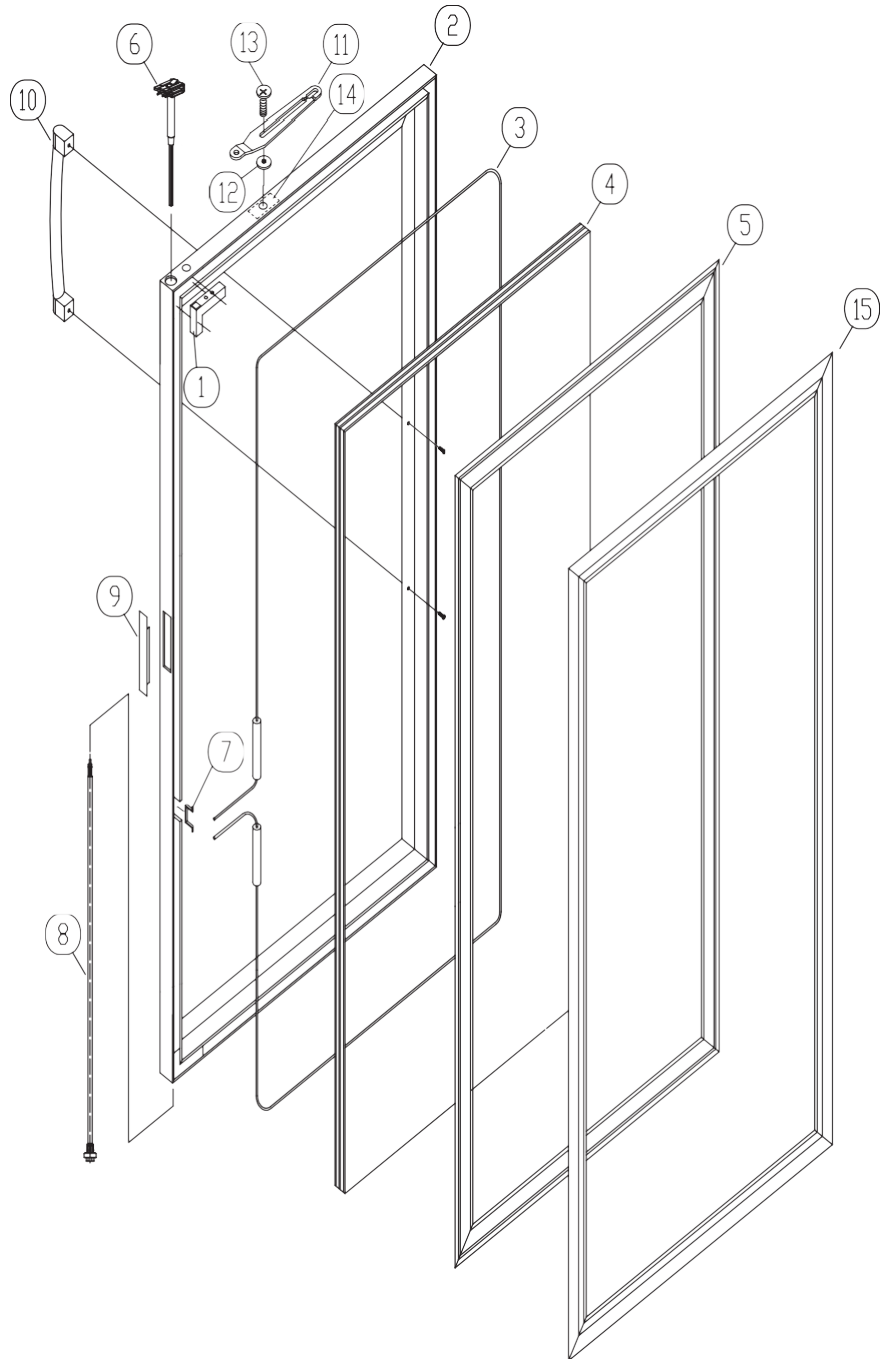

Note: For specific part numbers, provide serial plate information.

EXPLODED VIEW - FRAME

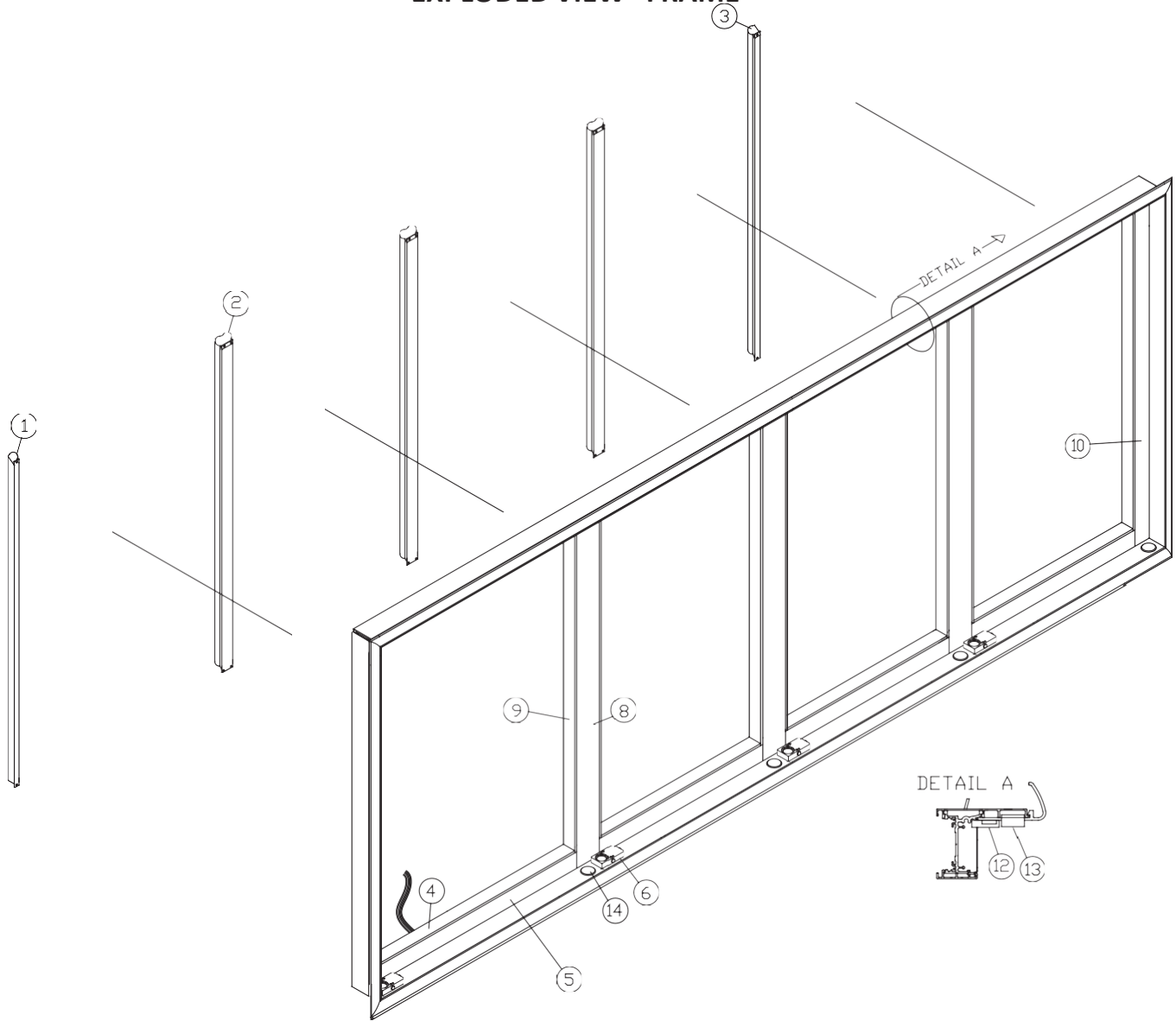

1. Left LED light fixture
2. Mullion LED light fixture
3. Right LED light fixture
4. Width vinyl
5. Width contact plate
6. Door Closer Adjuster

8. Mullion contact plate
9. Mullion vinyl
10. Vertical End Jamb contact plate
12. Receptacle
13. Gib
14. Rubber Plug

Note: For specific part numbers, provide serial plate information.

SHELVING INSTRUCTIONS

1. Thermoseal shelving is attached to the back of Thermoseal frame by quick-locking supports that are pre-assembled on these frames, as well as by holders attached to the front posts.
2. To install Thermoseal shelves, first locate a front post at one end of the Thermoseal frame. Insert the post holders into the post supports on the frame.
3. The post supports are distorted at the top of the engagement rail. After the post holders are installed, be sure to distort the bottom of the guide to prevent the guide from coming out.
4. Repeat step 3 until all of the front posts have been attached.
5. Thermoseal provides stabilizer bars to help in shelf installation. These bars are used to support posts while each opening is being erected, one opening at a time. Installing the shelves in each opening will provide strength and help in the shelf installation process.
6. After the first opening has been erected, move the stabilizer bars to the next opening to help in the assembly of posts. Repeat until the entire line-up has been complete.
7. Thermoseal shelves will engage in the slots on the back of each post. Note: The slots on Thermoseal posts face toward the rear of the cooler / freezer box.
8. Shelves and posts can be leveled by unscrewing the leveling bolt on the bottom of each post. Make sure the posts are level, both side-to-side and front-to-back.
9. Thermoseal shelves may be slanted by adjusting the rear of each shelf into a higher slot on the rear post than the front of the shelf.



CARE & CLEANING

Cleaning-Inside

The interiors of doors and frames should be cleaned at least once a year. Unplug the doors and frames before cleaning. If this is not practical, wring excess moisture out of sponge or cloth when cleaning around switches, lights, and controls.

Use a warm water and baking soda solution—about a tablespoon (15 ml) of baking soda to a quart (1 L) of water. This both cleans and neutralizes odors. Rinse thoroughly with water and wipe dry. When cleaning other parts of the doors and frames—including gaskets and all plastic parts—use the same solution. After cleaning door gaskets, apply a thin layer of food grade silicone sealant to the door gaskets at the hinge side. This helps to keep the gaskets from sticking and bending out of shape. Do not use cleansing powders or other abrasive cleaners.

Cleaning-Outside

The exteriors of doors and frames can be cleaned with a cloth dampened with a solution of mild liquid dishwashing detergent and water. Dry with a soft cloth.

Use a household wax, such as Pledge brand or Jubilee brand, to coat the handles. Soil will then easily wash off with dish detergent and water or a non-abrasive all-purpose cleaner. Glass can be cleaned with off-the-shelf glass cleaner (no ammonia).

Do not use scouring pads, powdered cleansers, bleach, or cleaners containing bleach and ammonia because these products can scratch and weaken the finish.

Revision History

REV	ORIGINATOR	DESCRIPTION OF CHANGE	DATE
A	HT	Initial Release	8/4/2023
B	HT	Update the hold open screw and pivot standoff pictures on sheet 10 & 12	10/11/2023
C	HT	Added additional warning dialog box for gasket lay flat against the frame on sheet 19	11/6/2023
D	HT	Remove the warranty section and added the safety and warning page	12/8/2025



INSTALLATION & SERVICE MANUAL

ADDITIONAL NOTES



THERMOSEAL®

www.thermoseal.com

Thermoseal Industries, LLC
5350 Frye Road
Irving, TX 75061

Phone: 800.456.7788
Email: info@thermoseal.com
Fax: 856.456.0989