

SCP-1 ORDER FROM

Quote/Order# _____

Company Name: _____

Attention: _____

Email: _____

Phone#: _____

Job Name: _____

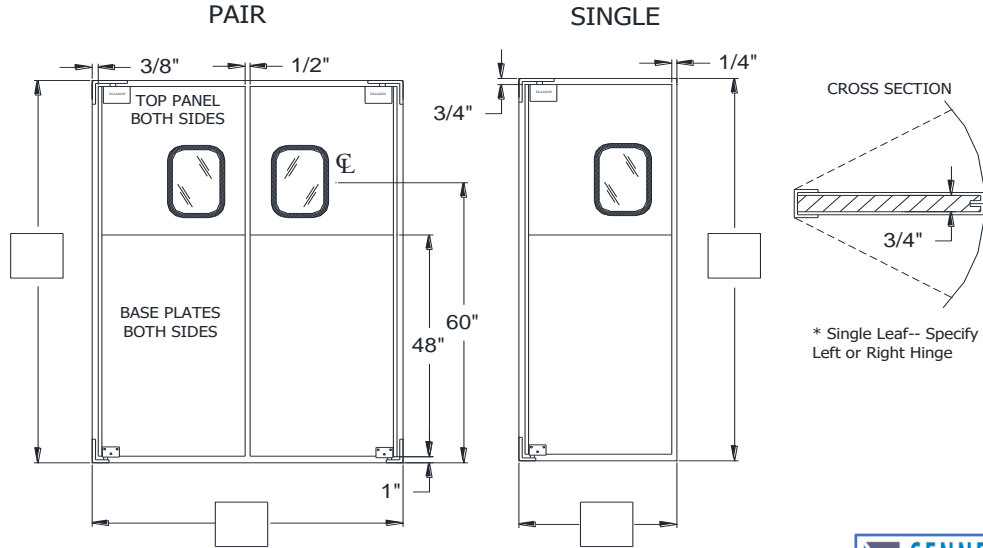

Fill in Opening Size in the Blanks Provided Above



STANDARD SPECIFICATIONS: Door body 3/4" moisture resistant composite wood core, metal clad. 48" high stainless steel base plates, both sides. .032" tempered aluminum alloy with satin anodized finish top panels, both sides. 9" x 14" clear acrylic safety window set in black rubber molding. Door assembly includes the original "NO SPRING" Easy Swing® hinges and both 1/4" - 20 x 1" thread cutting screws and #14 -1-1/2" sheet metal/wood screws for jamb by others.

INSTALLATION DETAILS: Jambs must be plumb and square. Minimum double 2 x 4 inch wood construction or equivalent. Hollow metal jambs should be reinforced at hinge locations.

SPECIFIC DETAILS FOR DOOR CONSTRUCTION:

WINDOW: Standard 9" X 14" In Black Rubber Molding, Up 60" to Center of Window from Floor
 Other: _____

JAMB GUARD: 3" X 9" 5" X 18"

PLATE: Height: Standard 48" Height Other Height: _____
 Color/Material: Standard Stainless Steel Galvanized Steel Black ABS

Other: _____

BUMPER: Standard Black Tear Drop Polyethylene, Height: 12 18 24 30 36 42
 Aluminum Bumper Strip:

OTHER SPECIFICATIONS: _____

APPROVED BY: _____

DATE: _____

Eliason Corporation

DOCUMENT NOT CONTROLLED WHEN PRINTED